

Series E

Quick Disconnect Couplings



Series E

Series E includes large diameter couplings which find their ideal application in medium pressure hydraulic and industrial applications.

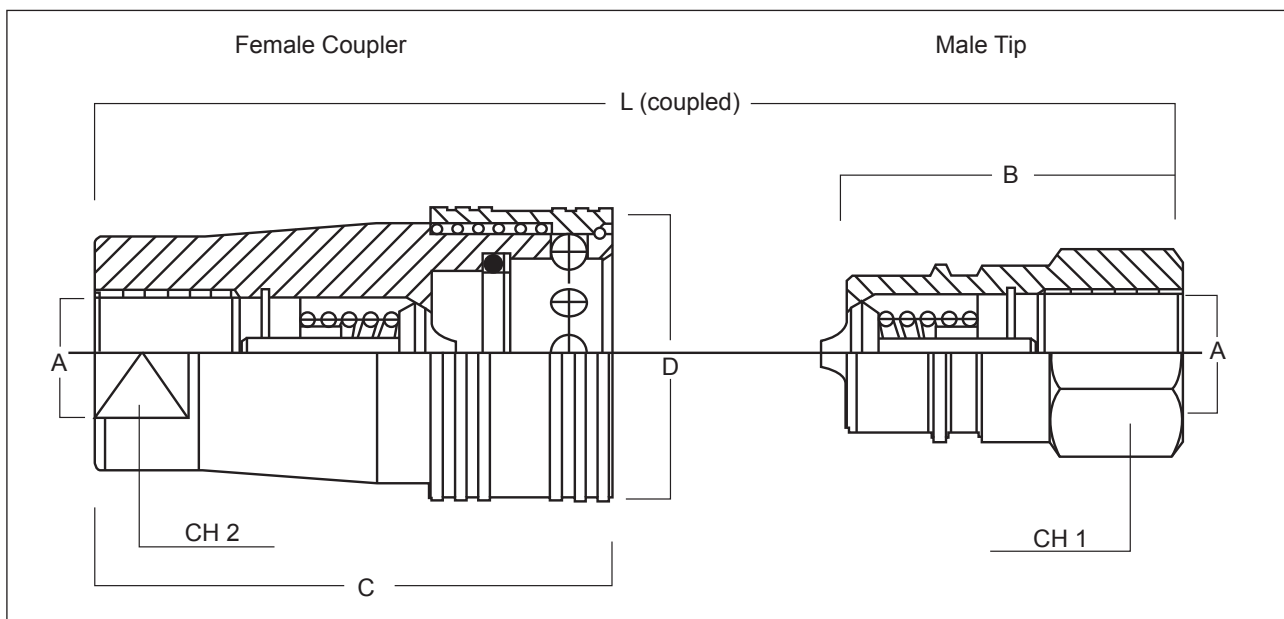

Dimensions										
Size Base	Ø DN	Code		Ø A	B	C	Ø D	L	CH 1	CH 2
	mm	Male Tip	Female Coupler	mm	mm	mm	mm	mm	mm	mm
20	32	EM1020	EF1020	1-1/4" BSP	70	110	70	140	50	50
24	38	EM1024	EF1024	1-1/2" BSP	70	114	81	141	60	55
32	50	EM1032	EF1032	2" BSP	89	139	114	177	70	70
40	63	EM1040	EF1040	2-1/2" BSP	89	139	114	177	84	84
50	76	EM1050	EF1050	3" BSP	100	155	139	200	100	100

Series E

Quick Disconnect Couplings

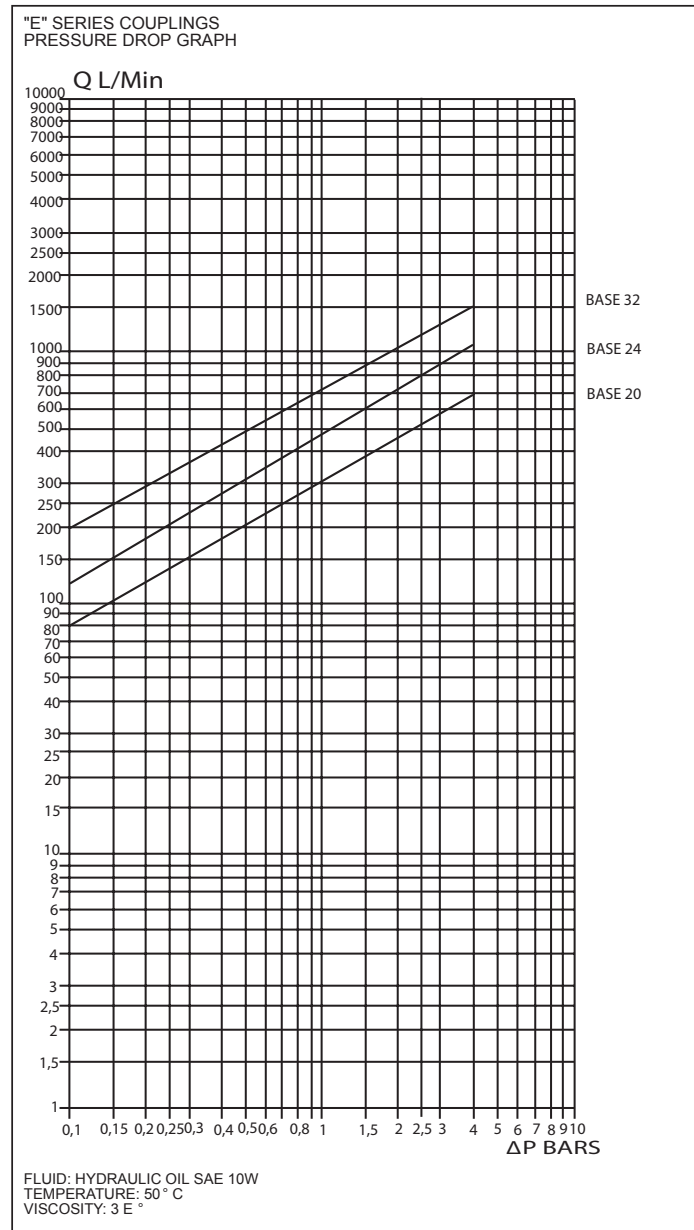

Performance Data

Size Base	Ø DN		Max. Working Pressure		Burst Pressure		Weight Kg	
	mm	inch	bar	psi	bar	psi	Male Tip	Female Coupler
20	32	1-1/4"	140	2030	560	8120	0.46	1.38
24	38	1-1/2"	120	1740	480	6960	0.72	1.82
32	50	2"	120	1740	480	6960	2.02	4.42
40	63	2-1/2"	100	1450	400	5800	1.82	4.05
50	76	3"	70	1015	280	4060	3.23	7.00

Series E



Quick Disconnect Couplings

Accessories

Part Number (Complete Coupler)	Seal Kit	Dust Cap (Protects Tip)	Dust Plug (Protects Body)	Colour
EC1020	ECSK1020			
EC1024	ECSK1024			
EC1032	ECSK1032			
EC1040	ECSK1040			
EC1050	ECSK1050			

Replacement Seal Kits

Replacement seal kits are available for most models. Leakage between the female body half (coupling) and the male tip half (nipple) is an indication that the body o-ring needs replacement.



Dust Caps & Dust Plugs

Protective dust caps and dust plugs are available in rubber in a variety of sizes. They should be used whenever possible to help reduce contamination of the hydraulic system and improve service life of the body half (coupling) and the mating tip half (nipple).

