

# SH20 Series

Quick Disconnect Couplings, General Purpose



## SH20 Series (1/4") - Standard Interchange

A general purpose quick coupler with one-way sleeve.

This 1/4" coupler is interchangeable half-for-half with the Parker/Pioneer SM Series and Aeroquip FD48 Series of quick couplings.

They are designed to work to pressures of 6,000 psi (414 bar) in the coupled mode.

### Performance Data

| Complete Coupler Code | Nominal Body Size (in.) | Thread Size NPT | Body (Female) Code | Tip (Male) Code | Rated Pressure |      | Check Type | Weight Kg. |
|-----------------------|-------------------------|-----------------|--------------------|-----------------|----------------|------|------------|------------|
|                       |                         |                 |                    |                 | Bar            | PSI  |            |            |
| SH20-2                | 1/4"                    | 1/4" NPT        | SH25-2             | SH21-2          | 276            | 4000 | Ball       | 0.16       |
| SH20-2P               | 1/4"                    | 1/4" NPT        | SH25-2P            | SH21-2P         | 276            | 4000 | Poppet     | 0.16       |
| SH20-14               | 1/4"                    | 9/16" UNO       | SH25-14            | SH21-14         | 276            | 4000 | Ball       | 0.16       |
| SH20-14P              | 1/4"                    | 9/16" UNO       | SH25-14P           | SH21-14P        | 276            | 4000 | Poppet     | 0.16       |

# SH20 Series

Quick Disconnect Couplings, General Purpose

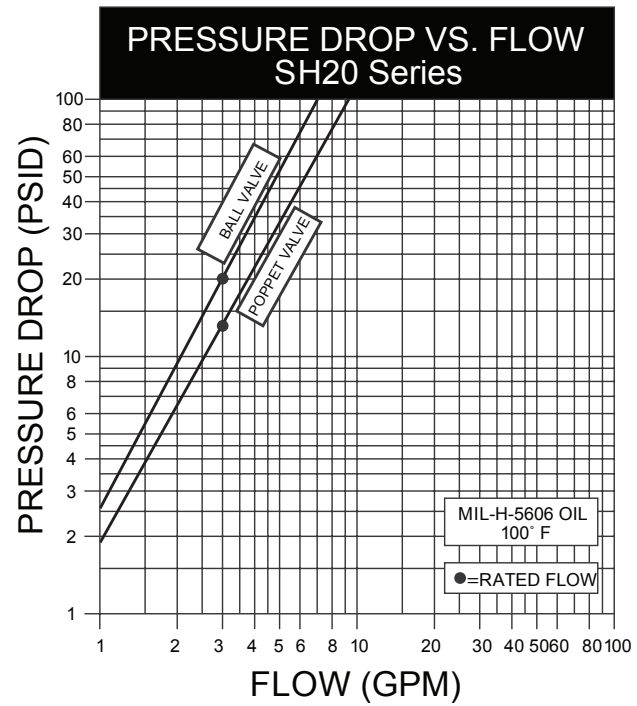
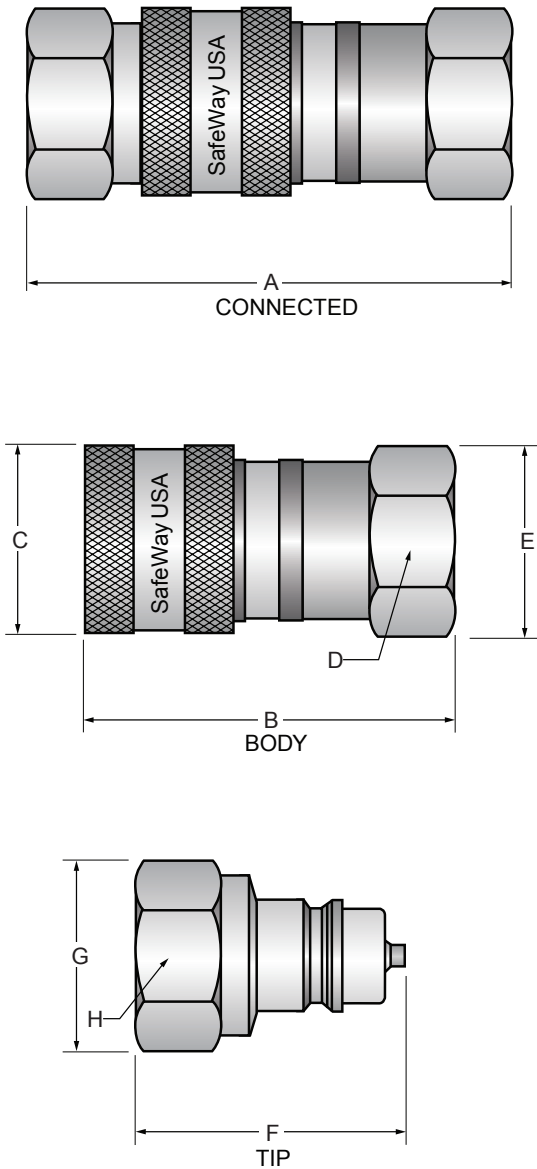

| Dimensions (inches)     |                |             |          |             |          |            |          |      |
|-------------------------|----------------|-------------|----------|-------------|----------|------------|----------|------|
| Complete Coupler Number | Overall Length | Body Length | Diameter | Wrench Flat | Diameter | Tip Length | Diameter | Hex  |
|                         | A              | B           | C        | D           | E        | F          | G        | H    |
| SH20-2                  | 2.52           | 1.94        | 1.09     | 0.75        | 0.88     | 1.32       | 0.86     | 0.75 |
| SH20-2P                 | 2.52           | 1.94        | 1.09     | 0.75        | 0.88     | 1.35       | 0.86     | 0.75 |
| SH20-14                 | 2.52           | 1.94        | 1.09     | 0.75        | 0.88     | 1.32       | 0.86     | 0.75 |
| SH20-14P                | 2.52           | 1.94        | 1.09     | 0.75        | 0.88     | 1.35       | 0.86     | 0.75 |

# SH20 Series

Quick Disconnect Couplings, General Purpose



## Accessories

| Part Number | Body O-Ring | Dust Cap<br>(Protects Tip)<br>Rubber with Chain | Dust Plug<br>(Protects Body)<br>Rubber with Chain |
|-------------|-------------|---|---|
| SH20-2 (P)  | S460-2      | S49-2   | S44-2   |
| SH20-14 (P) | S460-2      | S49-2   | S44-2   |

## Replacement Seal Kits

Both replacement seal kits and individual o-rings and back-up rings are available for most models. Leakage between the female body half (coupling) and the male tip half (nipple) is an indication that the body o-ring needs replacement.



## Dust Caps & Dust Plugs

Protective dust caps and dust plugs are available in rubber or metal in a variety of sizes. They should be used whenever possible to help reduce contamination of the hydraulic system and improve service life of the body half (coupling) and the mating tip half (nipple).

