

S51 Series



Quick Disconnect Couplings, Wing Type, Screw Together



S51 Series (3/4" - 1") - Heavy Duty, Double Shut-Off

The S51 Series quick coupling can be connected under full system pressure by rotating the female threaded heavy-duty ductile cast iron wing nut or steel hex nut onto the mating male threaded tip (nipple).

Applications include "wet-line-kits" used widely on dump trailers, mobile drilling rigs, mining equipment, salt spreaders and chemical transfer units.

Brass body, tip and poppet, combined with a rugged steel valve, provide corrosion resistance and durability.

Interchangeable half-for-half with the Parker 6100 Series, Aeroquip FD51 (5100) Series and Snap-Tite 78 Series.

Performance Data

Complete Coupler Code	Nominal Body Size (in.)	Thread Size NPT	Body (Female) Code	Tip (Male) Code	Rated Pressure		Check Type	Weight Kg.
					Bar	PSI		
S51W-6B	3/4"	3/4" NPT	S515W-6	S511-6	207	3000	Poppet	
S51W-8B	1"	1" NPT	S515W-8	S511-8	207	3000	Poppet	

S51 Series



Quick Disconnect Couplings, Wing Type, Screw Together

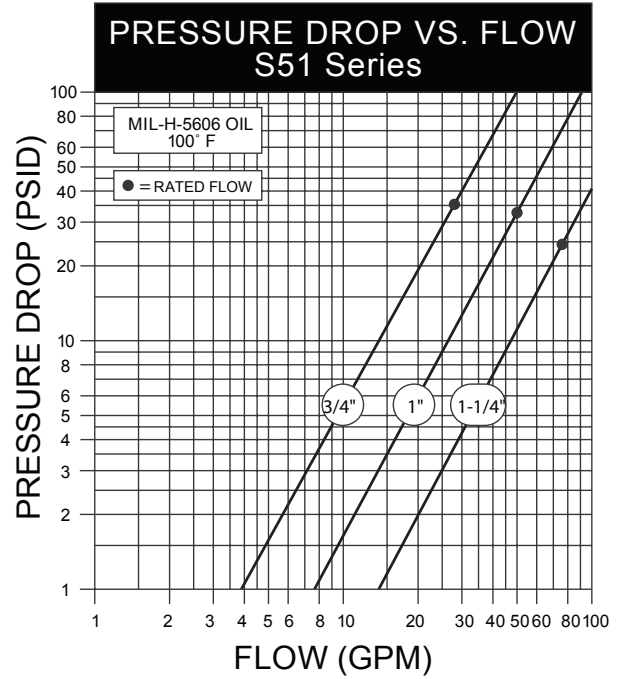
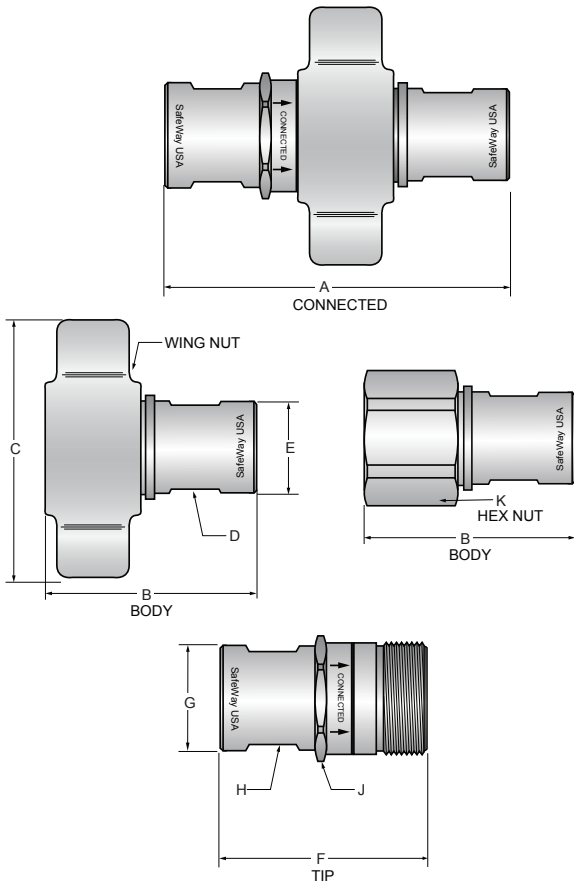

Dimensions (inches)										
Complete Coupler Number	Overall Length	Body Length	Wing Nut Length	Wrench Flat	Dia.	Tip Length	Dia.	Wrench Flat	Hex	Hex
	A	B	C	D	E	F	G	H	J	K
S51W-6B	4.75	2.72	4.06	1.16	1.25	3.05	1.36	1.16	1.62	-
S51W-8B	5.40	3.32	4.38	1.43	1.56	3.30	1.74	1.56	1.88	-