

Bell Housings

Bosch Pumps

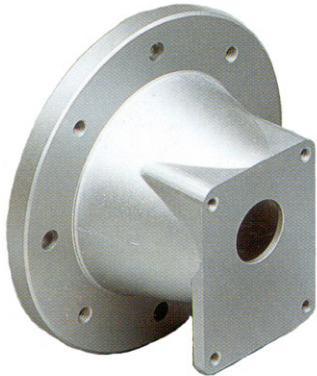

Features

- Manufactured of aluminium alloy these bell housings are machined to allow the assembly of Bosch series PZB, PZF and PZG pumps to metric frame electric motors.
- Suitable for electric motors with a metric frame size of D63 - D200.

Dimensional Details

Motor Frame	Bosch Pump Series	A	B	C	F	G	H	E	L	M	N	O	Bell Housing Stock Code
D63	ZB	140	115	95	100	60	11	32	10.3	40	40	M8	LB18
D71	ZB	160	130	110	110	70	14	32	10.3	40	40	M8	LB19
D80/90	ZB	200	165	130	135	95	15	32	10.3	40	40	M8	LB20
D80/90	ZF	200	165	130	135	95	15	80	34.5	100	72	M8	LB21
D80/90	ZG	200	165	130	135	126	16	105	65	196	143	M12	L2011
D100/112	ZB	250	215	180	185	105	21	32	10.3	40	40	M8	LB22
D100/112	ZF	250	215	180	185	115	21	80	34.5	100	72	M8	LB24
D100/112	ZG	250	215	180	185	115	21	105	48	145	102	M10	LB25
D132	ZF	300	265	230	238	143	21	80	34.5	100	72	M8	LB26
D132	ZG	300	265	230	238	143	21	105	48	145	102	M10	LB27
D160/180	ZF	350	300	250	253	178	25	80	34.5	100	72	M8	LB31
D160/180	ZG	350	300	250	253	178	25	105	48	145	102	M10	LB32
D200	ZG	400	350	300	299	188	25	105	48	145	102	M10	LB30

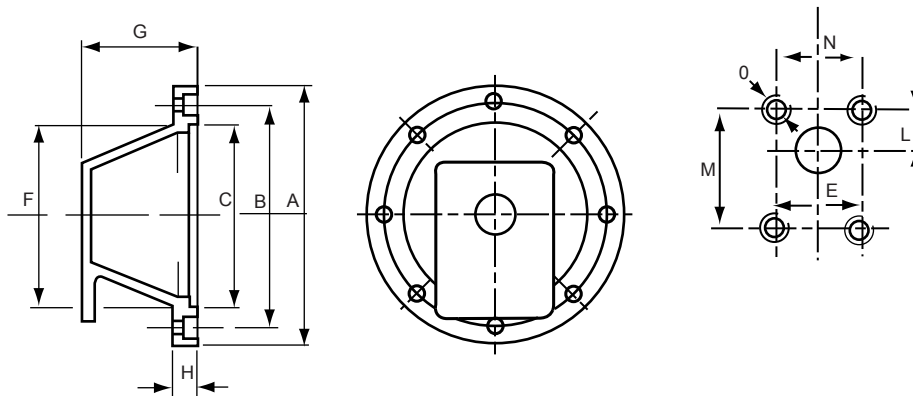

Drive Couplings



Bosch Gear Pumps 1 : 5 Taper

Features



- ND & NS flexible couplings are manufactured from aluminium alloy with an oil proof rubber element providing silent operation and a long life.

- Permissible torque transmission should be calculated from the table shown on the Bell Housings/Couplings General Information page.

Dimensional Details

Motor Coupling Half					Pump Coupling Half						
Stock Code	A	C	G	D	Stock Code	A	B	E	I	d	ch
ND48A	48	30	19	11	ND48PZB	48	30	17	10.2	9.8	2
ND48B	48	30	29	14							
ND48C	48	38	54	19							
ND65A	65	42	47.5	19	ND65PZB	65	34	21.5	10.2	9.8	2
ND65B	65	48	47.5	24	ND65PZF	65	34	21.5	17.7	16.9	3
ND65C	65	53	57.5	28	ND65QZF	65	48	31.5	17.7	16.9	3
ND65D	65	42	47.5	24	ND65QZG	65	48	31.5	26.3	25.2	5
ND86A	86	55	60	28	ND86HZG	86	55	48	26.3	25.2	5
ND86B	86	73	88	38	ND86PZF	86	48	27	17.7	16.9	3
ND86HD20	86	55	48	19	ND86PZG	86	48	27	26.3	25.2	5
ND86HD31	86	55	48	24							
ND108B	108	84	110	42	ND108PZF	108	64	34	17.7	16.9	3
ND108C	108	100	110	48	ND108PZG	108	64	34	26.3	25.2	5
ND108D	108	100	110	55	ND108QZG	108	64	42	26.3	25.2	5

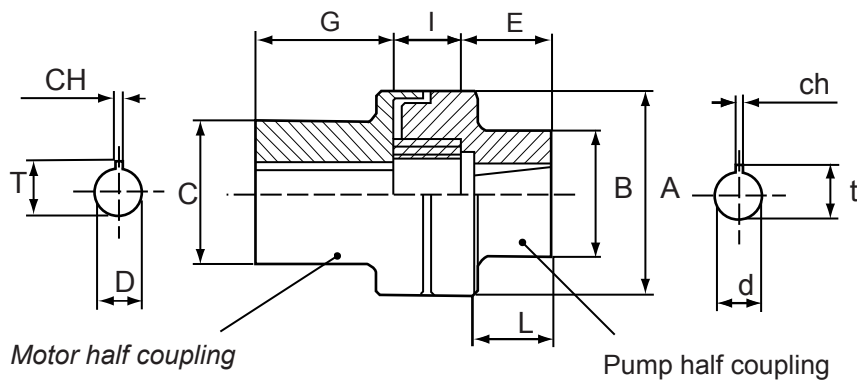

Recommended Assemblies



Bosch Gear Pump 1 : 5 Taper

Motor Frame Size	Pump Group Size	Bell Housing	Motor Coupling Half	Rubber Spider	Pump Coupling Half
D63	ZB	LB18	ND48A	R42	ND48PZB
D71	ZB	LB19	ND48B	R42	ND48PZB
D80	ZB	LB20	ND48C	R42	ND48PZB
D80	ZF	LB21	ND65A	R62	ND65PZF
D80	ZG	LB2011	ND86HD20	R82	ND86HZG
D90	ZB	LB20	ND65B	R62	ND65PZB
D90	ZF	LB21	ND65D	R62	ND65PZF
D90	ZG	LB2011	ND86HD31	R82	ND86HZG
D100/112	ZB	LB22	ND65C	R62	ND65PZB
D100/112	ZF	LB24	ND86A	R82	ND86PZF
D100/112	ZG	LB25	ND86A	R82	ND86PZG
D132	ZF	LB26	ND86B	R82	ND86PZF
D132	ZG	LB27	ND86B	R82	ND86PZG
D160	ZF	LB31	ND108B	R103	ND108PZF
D160	ZG	LB32	ND108B	R103	ND108PZG
D180	ZF	LB31	ND108C	R103	ND108PZF
D180	ZG	LB32	ND108C	R103	ND108PZG
D200	ZG	LB30	ND108D	R103	ND108QZG