

Accessories for Bell Housings



Damping Rings and Foot Flanges

Damping Rings - A Series



Features

These articles are made of two rings moulded into vulcanized rubber. Interposed between the bell housing and the tank cover, they diminish the vibrations created by the power transmission by approx. 3-5 dB. The employed rubber is mineral oil resistant; maximum working temperature is 80°C.

Type	Dimensions mm					
	A	B	C	D	E	F
A-200	145	200	165	15	43	M10
A-250	190	250	215	18	49	M12
A-300	235	300	265	18	56	M12
A-350	260	350	300	24	63	M16
A-400	311	400	350	24	70	M16

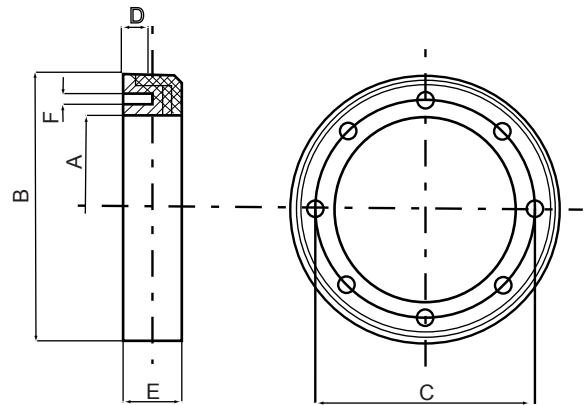

Foot Flanges - P Series



Features

Manufactured from high resistance aluminium alloy, these flanges are used to support our bell housings with standard B5 flange up to an external motor diameter of 350mm.

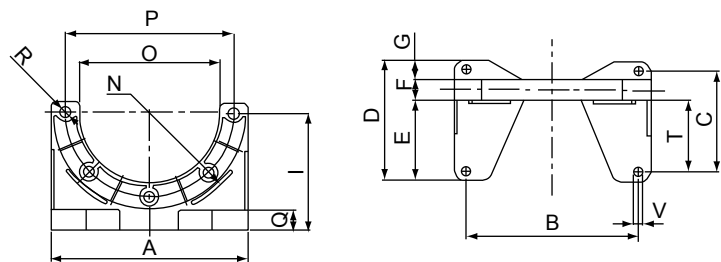

Type	Dimensions mm														
	A	B	C	D	E	F	G	I	N	O	P	Q	R	T	V
P160	165	135	80	100	45	10	45	98	80	111	130	10	9	35	9
P200	202	168	103	125	54	19	54	123	100	140	165	22	11.5	42.5	9
P250	252	220	130	155	105	25	25	150	125	180	215	25	13	92.5	11
P300	302	265	160	190	115	25	50	175	150	240	265	25	13	100	13
P350	362	310	250	286	183	30	73	205	175	256	300	30	18	165	15