

EC-PWM-08-MPC4-H PWM DRIVER

DESCRIPTION

Microprocessor-based PWM driver for remote control of 4 dual-coil proportional solenoid valves.

OPERATION

The EC-PWM-08-MPC4 proportional valve driver supplies up to four dual-coil proportional solenoid valves with PWM (Pulse Width Modulated) current proportional to the input signals coming from potentiometers, PLC or other control systems. PWM currents are factory pre-set and cannot be adjusted.

FEATURES

- The current in the solenoid is independent from any change in the coil resistance or in the supply voltage.
- The inherent superimposed dither frequency helps to overcome friction and stiction effects in the controlled device.
- Supply line is protected against reversed polarity and load dump.
- Inputs are protected against short circuits to GND and supply.
- Outputs are protected against short circuits, reversed polarity, over-current and over-temperature.
- The EC-PWM-08-MPC4-H is completely potted.
- Electro Magnetic Compatibility (EMC): EN 61000-6-2 (Immunity), EN 61000-6-3 (Emissions).



SPECIFICATIONS

Operating voltage:	9÷30 VDC
Max current consumption:	100 mA (no load applied)
Operating temperature:	-40°C / +100°C
Degree of protection:	IP 67
Input impedance:	100 kΩ
Analog inputs:	6 x 0-5 V
Typical ctrl pot resistance:	1÷10 kΩ
Digital inputs:	2 x PNP (Active High)
Resolution:	10 bit
PWM outputs channels:	4 x dual-coil proportional valves
Current output range (PWM):	100÷1500 mA
PWM dither frequency:	75÷250 Hz (factory pre-set, standard 100 Hz)

APPLICATIONS

- Specifically designed for applications with factory-set working parameters and requiring no field-adjustments.
- 12 VDC and 24 VDC systems.
- Remote control of proportional valves.
- Control of a 4 functions proportional bidirectional system.

DIMENSIONS

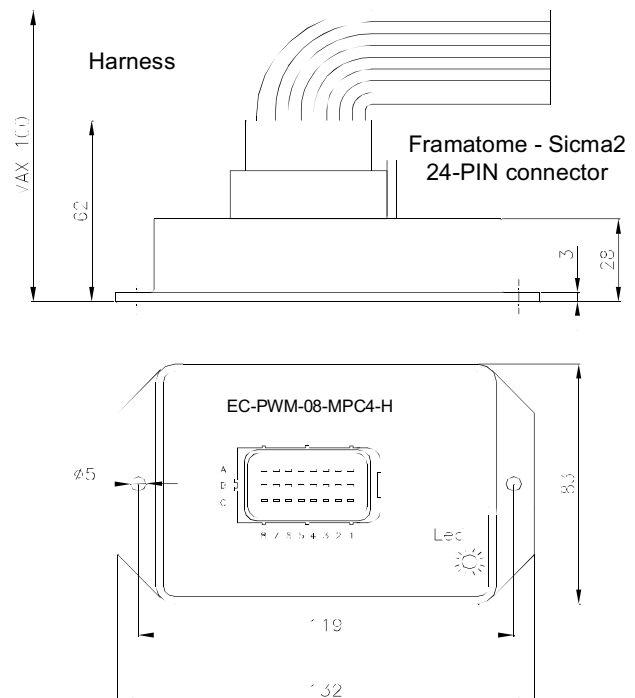

WARNING: the specifications/application data shown in our catalogs and data sheets are intended only as a general guide for the product described (herein). Any specific application should not be undertaken without independent study, evaluation, and testing for suitability.



4484 Boeing Drive Rockford, IL 61109 • USA • Phone +1 (815) 397-6628 • Fax +1 (815) 397-2526
mail: delta@delta-power.com • www.delta-power.com



Via Malavolti, 36 • 41122 Modena • ITALY • Phone +39 (059) 254895 • Fax +39 (059) 253512
mail: tecnord@tecnord.com • www.tecnord.com

EC-PWM-08-MPC4-H PWM DRIVER

CIRCUIT BOARD PINOUT - WIRING DIAGRAM

Connector type: framatome SICMA2

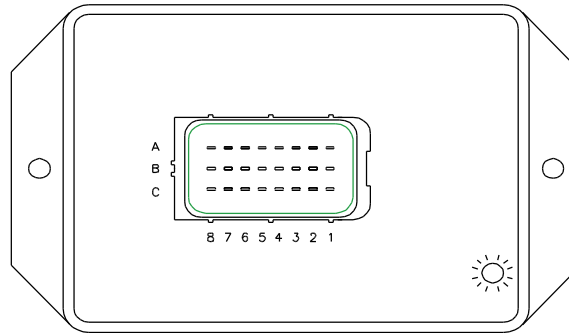

- | | | |
|--|---|---|
| A
1 EV4A PROP. COIL OUTPUT FEEDBACK (-)
2 EV4B PROP. COIL OUTPUT FEEDBACK (-)
3 EV3A PROP. COIL OUTPUT FEEDBACK (-)
4 EV3B PROP. COIL OUTPUT FEEDBACK (-)
5 ANALOG INPUT FOR FUNCTION 4 (TO DRIVE EV4A/B)
6 ANALOG INPUT FOR FUNCTION 3 (TO DRIVE EV3A/B)
7 ANALOG INPUT FOR FUNCTION 1 (TO DRIVE EV1A/B)
8 COMMON COMMAND FOR EV1A/B (+) | B
1 +V (POWER SUPPLY)
2 ANALOG INPUT - SPARE
3 ANALOG INPUT - SPARE
4 ANALOG INPUT FOR FUNCTION 2 (TO DRIVE EV2A/B)
5 ANALOG INPUT - SPARE
6 COMMON COMMAND FOR FOR EV2A/B (+)
7 COMMON COMMAND FOR EV4A/B (+)
8 COMMON COMMAND FOR EV3A/B (+) | C
1 -V (POWER SUPPLY - GND)
2 +5 VDC EXTERNAL SUPPLY VOLTAGE
3 DIGITAL INPUT - SPARE
4 DIGITAL INPUT - SPARE
5 EV1A PROP. COIL OUTPUT FEEDBACK (-)
6 EV1B PROP. COIL OUTPUT FEEDBACK (-)
7 EV2A PROP. COIL OUTPUT FEEDBACK (-)
8 EV2B PROP. COIL OUTPUT FEEDBACK (-) |
|--|---|---|

ADJUSTMENTS

Factory pre-set for:

- **I_{min}** (minimum output current)
- **I_{max}** (maximum output current)
- **Ramp-up time**
- **Ramp-down time**
- **Dither frequency**

Factory pre-set values for the standard version p/n 23.0409.170:

- **I_{min} = 100 mA**
- **I_{max} = 1500 mA**
- **Ramp-up/-down time = 0 sec**
- **Dither frequency = 100 Hz**

APPLICATION EXAMPLE

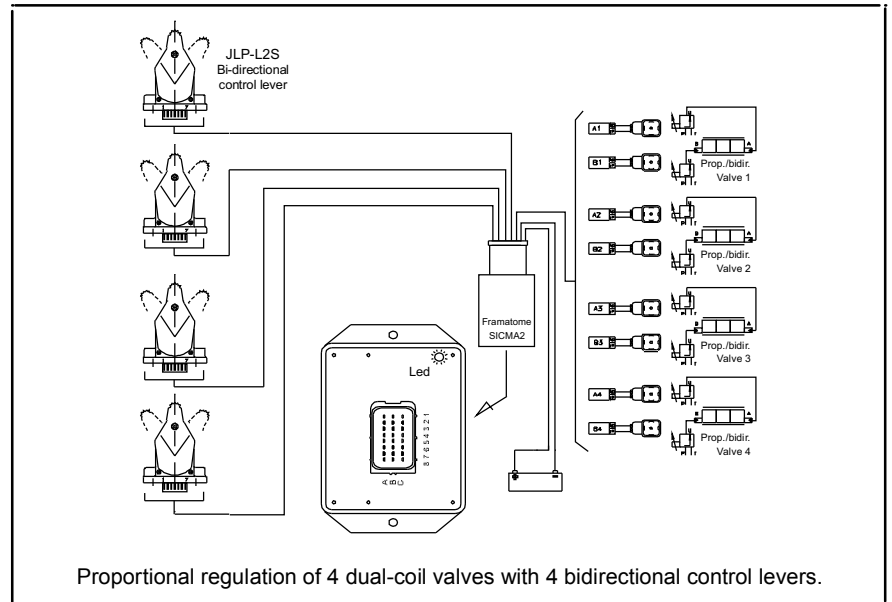

ORDERING INFORMATION

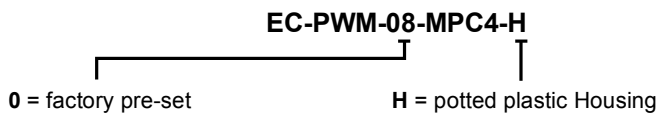

Part numbers	Version
23.0409.170	1.5 A

W/27 / 2021

WARNING: the specifications/application data shown in our catalogs and data sheets are intended only as a general guide for the product described (herein). Any specific application should not be undertaken without independent study, evaluation, and testing for suitability.



4484 Boeing Drive Rockford, IL 61109 • USA • Phone +1 (815) 397-6628 • Fax +1 (815) 397-2526
 mail: delta@delta-power.com • www.delta-power.com



Via Malavolti, 36 • 41122 Modena • ITALY • Phone +39 (059) 254895 • Fax +39 (059) 253512
 mail: tecnord@tecnord.com • www.tecnord.com

EC-PWM-P8-MPC4-H PWM DRIVER

DESCRIPTION

Microprocessor-based PWM driver for remote control of 4 dual-coil proportional solenoid valves.

OPERATION

The EC-PWM-P8-MPC4 proportional valve driver supplies up to four dual-coil proportional solenoid valves with PWM (Pulse Width Modulated) current proportional to the input signals coming from potentiometers, PLC or other control systems. The control characteristics (I_{min}/I_{max} , ramps, dither) are configurable via PC connected with a RS232 serial line to a configuration kit and PC interface of Tecnorm supply.

FEATURES

- The current in the solenoid is independent from any change in the coil resistance or in the supply voltage.
- The inherent superimposed dither frequency helps to overcome friction and stiction effects in the controlled device.
- Supply line is protected against reversed polarity and load dump.
- Inputs are protected against short circuits to GND and supply.
- Outputs are protected against short circuits, reversed polarity, over-current and over-temperature.
- The EC-PWM-P8-MPC4-H is completely potted.
- Electro Magnetic Compatibility (EMC): EN 61000-6-2 (Immunity), EN 61000-6-3 (Emissions).



SPECIFICATIONS

Operating voltage:	9÷30 VDC
Max current consumption:	100 mA (no load applied)
Operating temperature:	-25°C / +85°C
Degree of protection:	IP 67
Input impedance:	100 kΩ
Analog inputs:	8 x 0-5 V
Typical ctrl pot resistance:	1÷10 kΩ
Digital inputs:	analog inputs can be used as digital
Resolution:	10 bit
PWM outputs channels:	4 x dual-coil proportional valves
Current output range (PWM):	100÷1500 mA (3 A version available)
PWM dither frequency:	75÷250 Hz (adjustable)

APPLICATIONS

- Specifically designed for applications requiring accurate adjustments and calibrations.
- 12 VDC and 24 VDC systems.
- Remote control of non-feedback proportional valves.
- Control of up to 4 proportional bidirectional valves.

DIMENSIONS

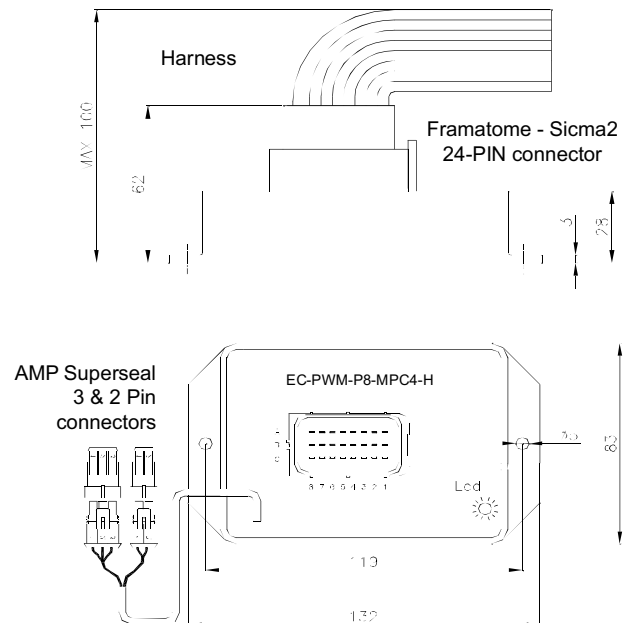

WARNING: the specifications/application data shown in our catalogs and data sheets are intended only as a general guide for the product described (herein). Any specific application should not be undertaken without independent study, evaluation, and testing for suitability.



4484 Boeing Drive Rockford, IL 61109 • USA • Phone +1 (815) 397-6628 • Fax +1 (815) 397-2526
mail: delta@delta-power.com • www.delta-power.com



Via Malavolti, 36 • 41122 Modena • ITALY • Phone +39 (059) 254895 • Fax +39 (059) 253512
mail: tecnord@tecnord.com • www.tecnord.com

EC-PWM-P8-MPC4-H PWM DRIVER

CIRCUIT BOARD PINOUT - WIRING DIAGRAM

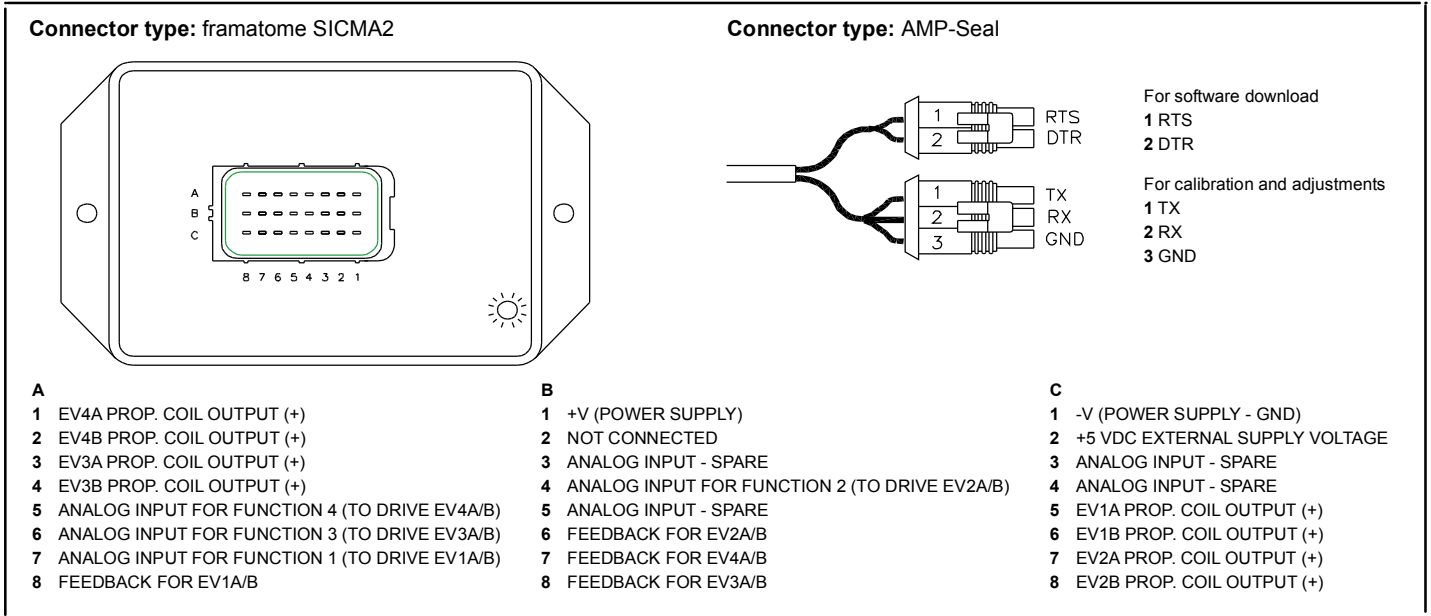

ADJUSTMENTS

Adjustments can be effected via RS232 serial line to modify the following work parameters:

- **I_{min}** (minimum output current)
- **I_{max}** (maximum output current)
- **Ramp-up time**
- **Ramp-down time**
- **Dither frequency**

Calibration tool ordering code: 20.1001.026/A
RS232 cable adapter for PC connection including calibration software on CD (see page EC44-45).

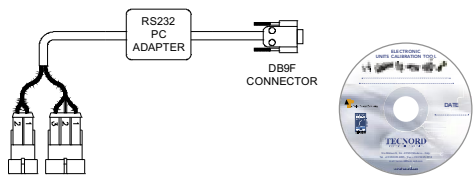

Note: USB/RS232 interface available on request.

APPLICATION EXAMPLE

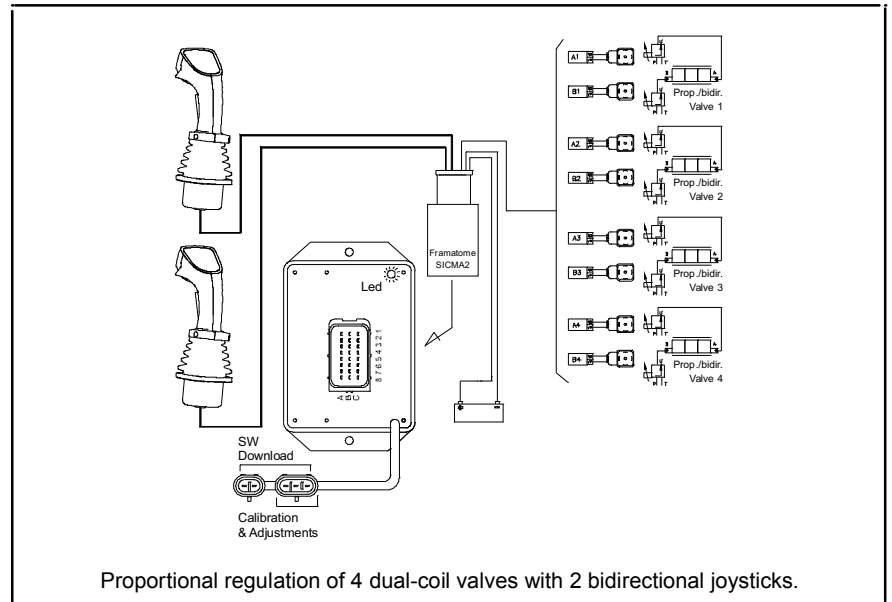

ORDERING INFORMATION

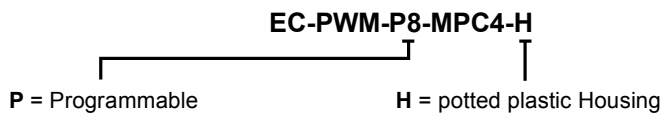

Part numbers	Version
23.0409.081	1.5 A
23.0409.071	3 A