

# HPM 28 Series

High Pressure Filters



## Features

Manufactured from a cast iron head and steel bowl this range of high pressure filters are used in pressure lines to provide system protection from fluid contamination.

Options available include a range of filter elements from 3 micron to 25 micron in both low and high collapse construction in an assortment of media as well as Visual and Electrical/Visual clogging indicators.

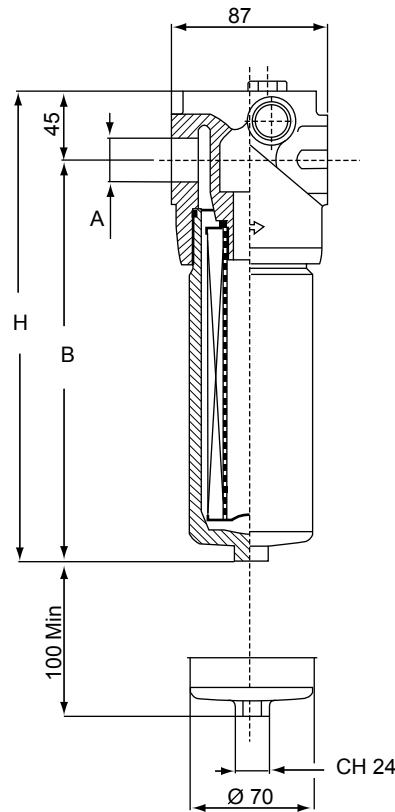
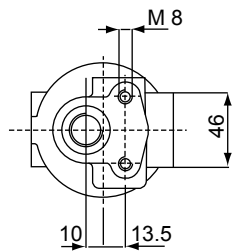
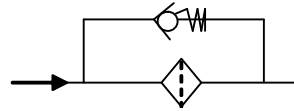
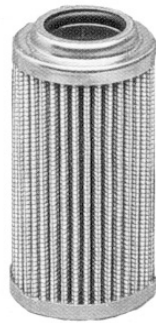
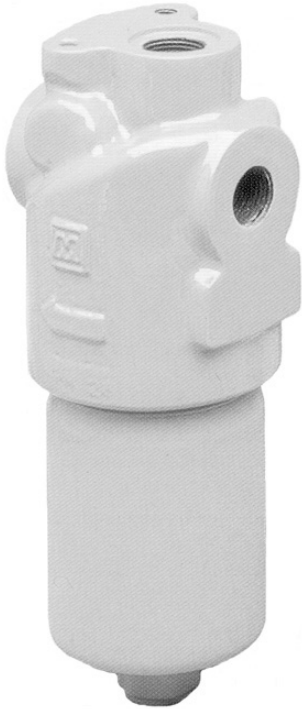

## Dimensional Details

Series	Type	A					B	H	
		1	2	3	4	5			
HPM	281	1/2" BSP	3/4" BSP	1/2" BSP	3/4" NPT	SAE 8 3/4" - 16 UNF	SAE 12 1-1/16" - 12 UN	144	189
	282							169	214
	283							265	310

# HPM 28 Series

High Pressure Filters



## How to Order

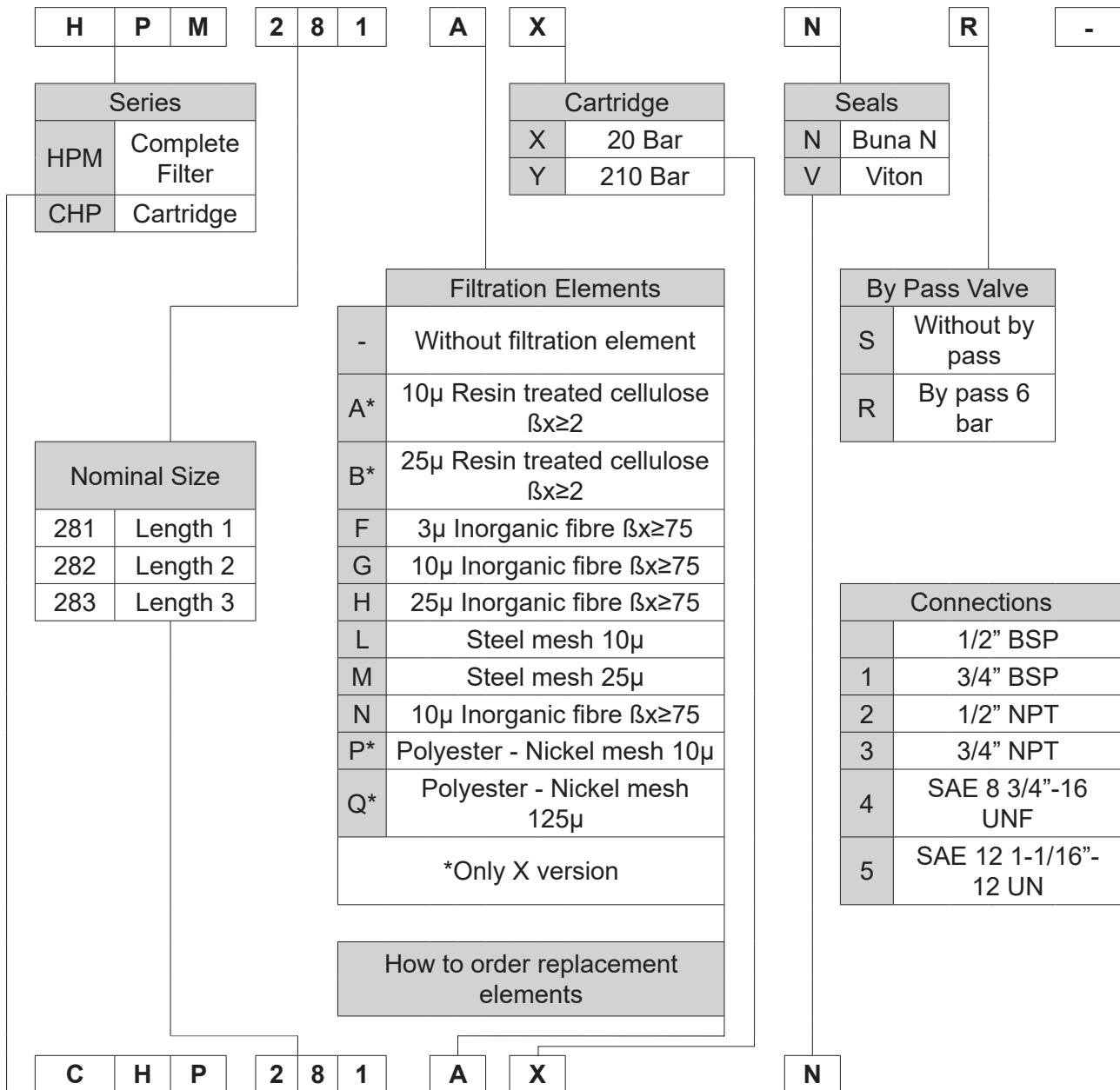

## Head Pressure Drop

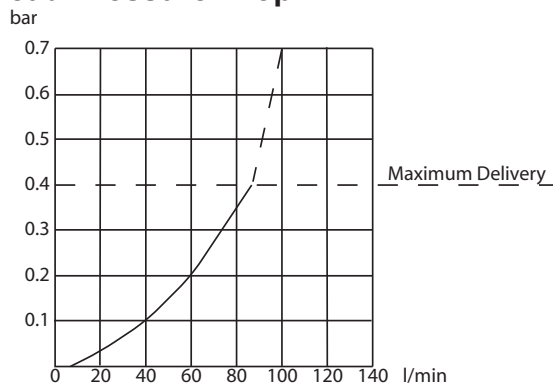

## Pressure Drop in By Pass Valve

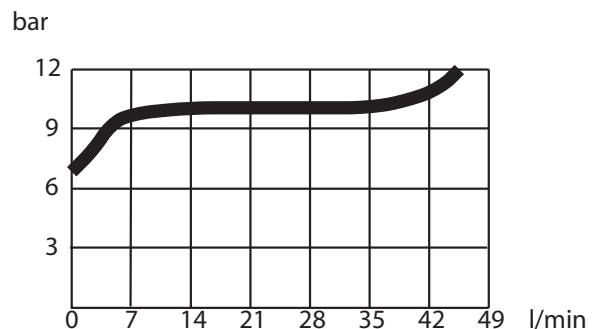

# HPM 28 Series

High Pressure Filters



## Filter Element Pressure Drop (low differential pressure)

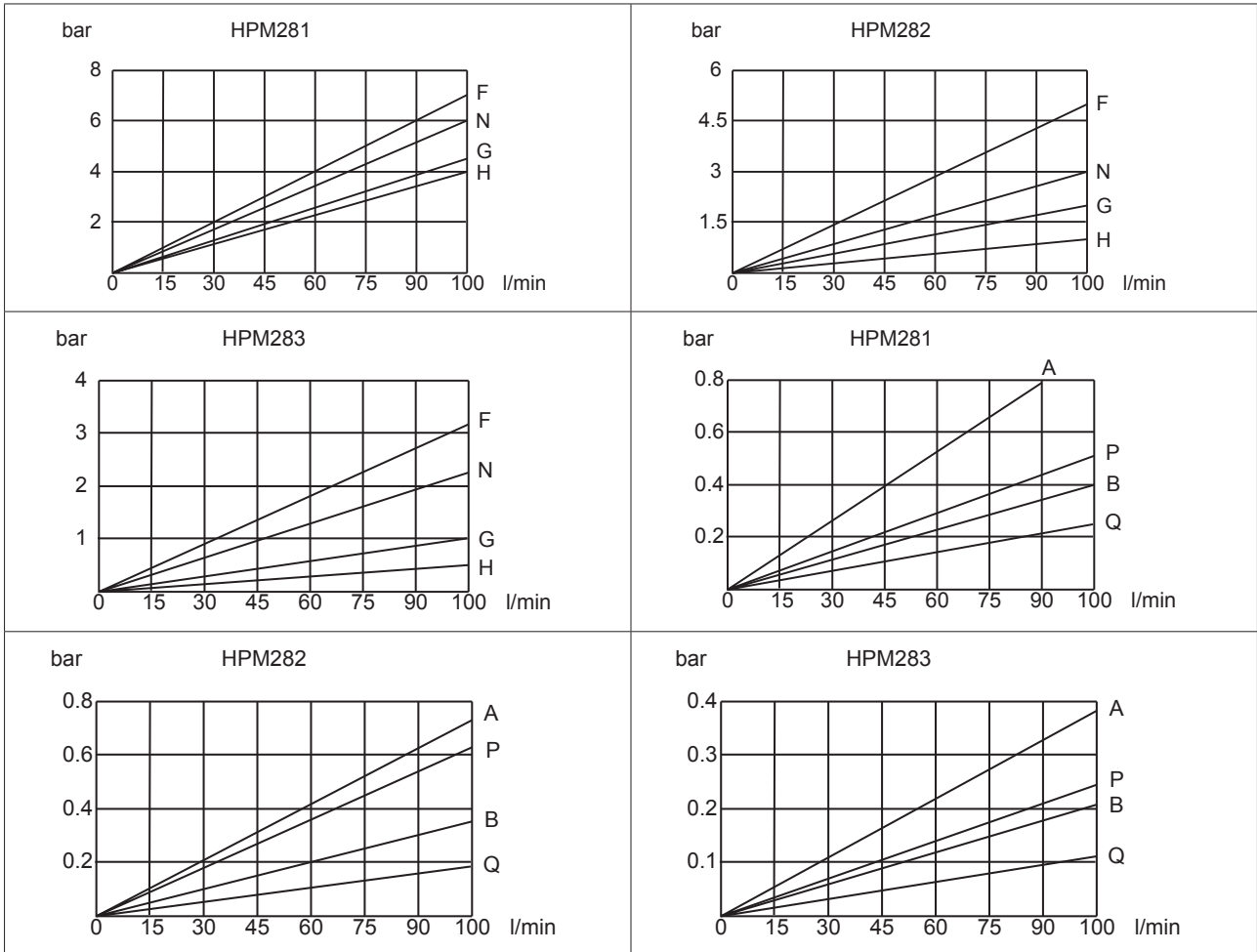

## Filter Element Pressure Drop (high differential pressure)

