

HPM 62 Series

High Pressure Filters



Features

Manufactured from a cast iron head and steel bowl this range of high pressure filters are used in pressure lines to provide system protection from fluid contamination.

Options available include a range of filter elements from 3 micron to 25 micron in both low and high collapse construction in an assortment of media as well as Visual and Electrical/Visual clogging indicators.

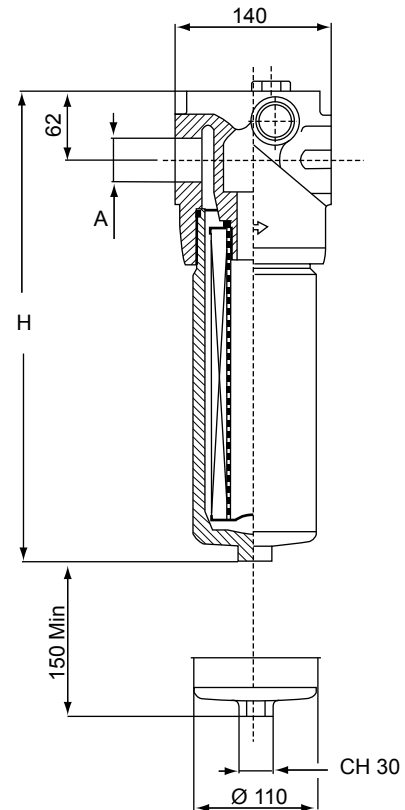
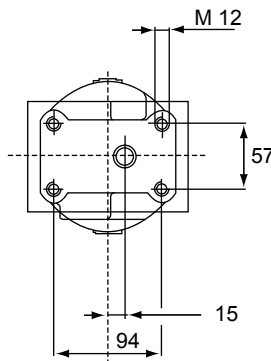
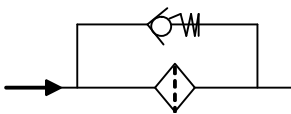
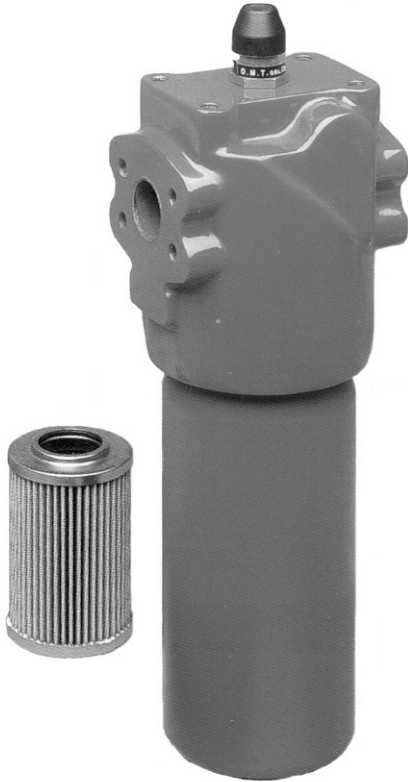

Dimensional Details

Series	Type	A													B	H
		1	2	3	4	5	6	7	8	9	10	11	12	13		
HPM	621	See connection table in How to Order.													211	273
	622														331	393
	623														471	533
	624														611	673

HPM 62 Series

High Pressure Filters



How to Order

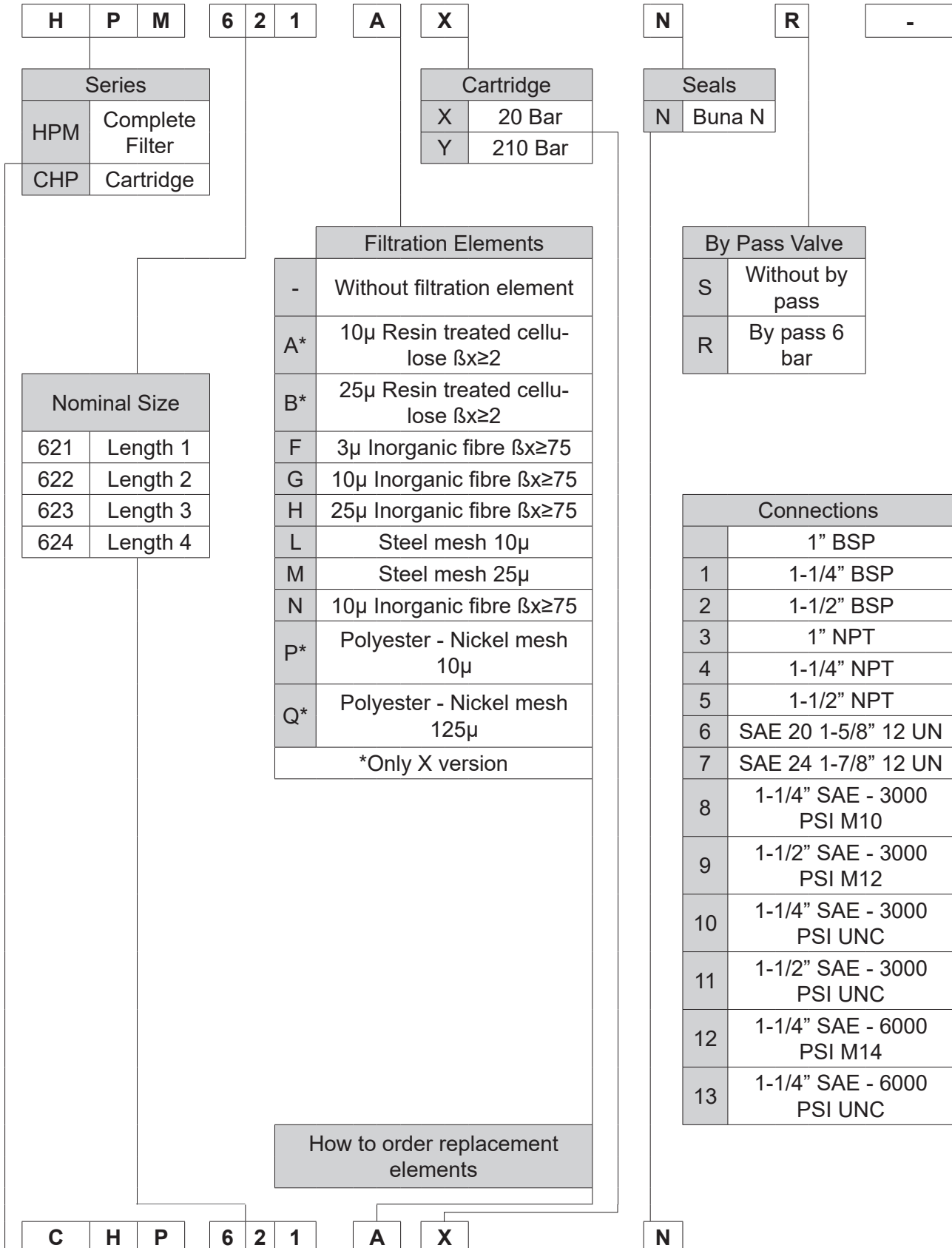

HPM 62 Series

High Pressure Filters



Head pressure drop

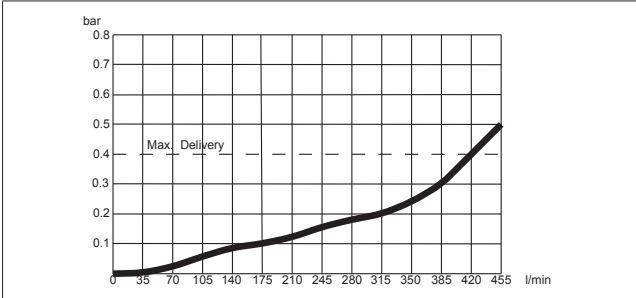

Pressure drop in bypass valve

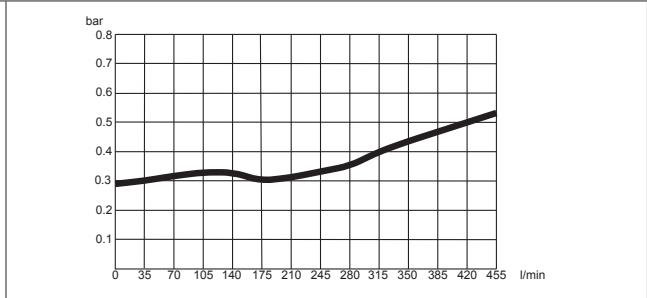

Filter Element Pressure Drop (low differential pressure)

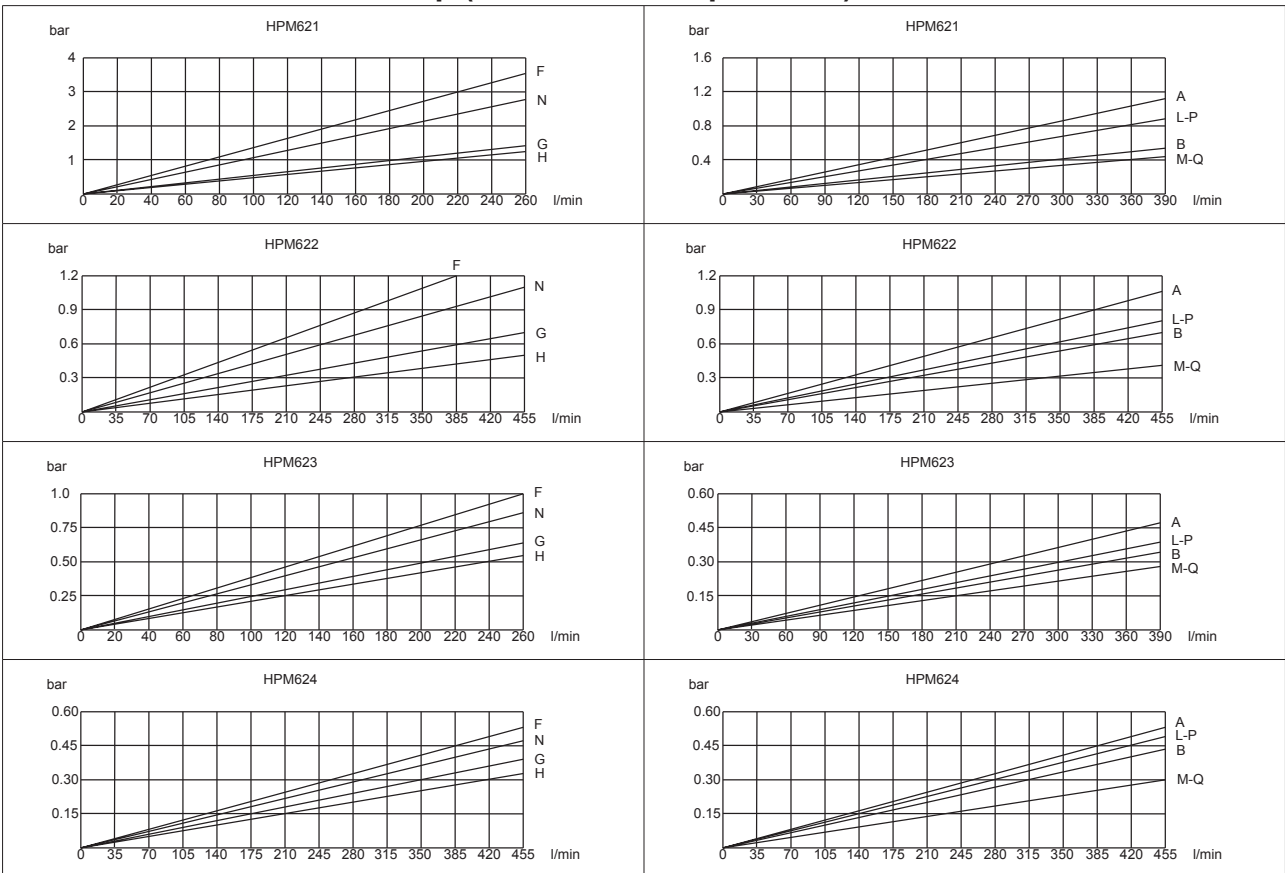

Filter Element Pressure Drop (high differential pressure)

