



# ML32 Series

Pump Drive Gearboxes



## DIMENSIONAL DETAILS mm (inches)

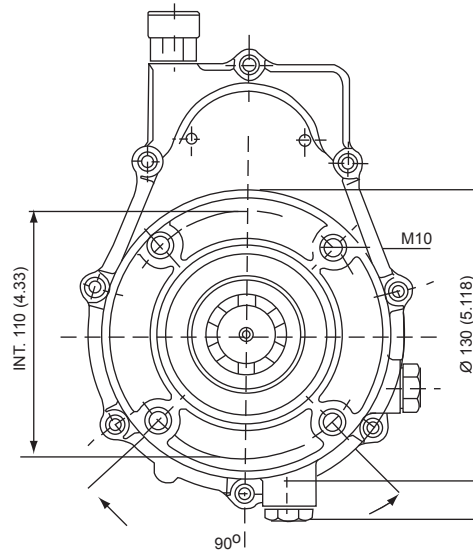

**NOTE:** Gearboxes are supplied complete with Part No. 31000900 Splined Adaptor which interfaces with the standard 14.3mm dia, 1:8 Taper x 3.2mm keyway Standard Group 2 Pump shaft and the female splined drive shaft in the gearbox.

## SERVICE NOTES

Correct lubrication is the determining factor for long gearbox life. The gearbox should be filled with a SAE 90 specification gear oil to the level indicated in the sight glass. This level should be checked frequently to ensure that it is maintained.

The oil should be changed after the first 30 - 50 hours of operation and subsequently changed every 12 months.

## HOW TO ORDER

ML32  
Series Code

2

CODE No.	INPUT SHAFT SPECIFICATION
1	Male 1-3/8" Dia x 6T DIN 9611
2*	Female 1-3/8" Dia x 6T DIN 9611
3	Female 1-3/8" Dia x 6T DIN 9611 with 'Quick Disconnect' adaptor

\* Standard