

RCM Series

Hydraulic Remote Controls



Sectional hydraulic remote control 2 service ports, single control levers

The hydraulic remote control RCM is capable of working with a maximum input pressure of 100 bar at a maximum oil input capacity of 16 l/min.

Low operating efforts, low energy consumption and low maintenance makes these hydraulic remote controls ideal for piloting remote control directional valves, variable displacement pumps and motors, auxiliary valves, frictions and hydraulic brakes.

Operating principle

The hydraulic remote control RCM works according to the principle of direct-acting pressure reducing valves. In rest position, the joystick lever is held in neutral by the return spring; inlet port P is closed and ports are connected to tank port T. By selecting control lever, plunger compresses return spring and reaction spring through a cam mechanism; consequently it shifts the spool and opens the connection holes between inlet port P and service ports.

This causes a pressure increase on service ports that is proportional to the control lever stroke and the reaction spring.

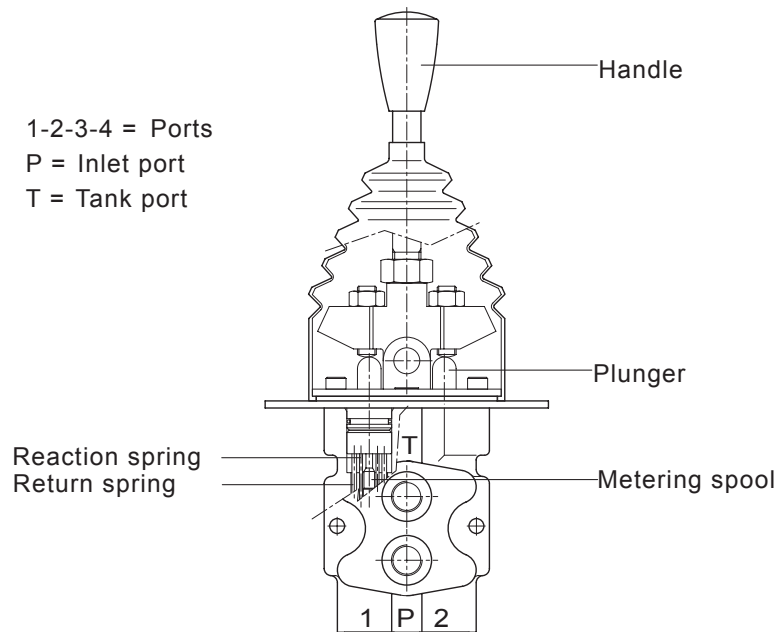

Standard Working Conditions	
Maximum input pressure	1450 psi
Maximum back pressure on tank line	44 psi
Oil input capacity	4.2 gpm
Hysteresis	7.25 psi
Hydraulic fluid	Mineral oil
Fluid temperature range	-20°C - +80°C
Fluid viscosity range	10÷300 Cst
Recommended filtration	25 µ Absolute
Recommended operating pipes	8mm rigid, 1/4" BSP flexible
Leakage	3 cc/min (50 bar)
Technical Specifications	
Body	Cast iron
Surface coating	Zinc plated
Plunger	Stainless steel
Plunger guide	Brass

RCM Series

Hydraulic Remote Controls



Dimensional drawing:

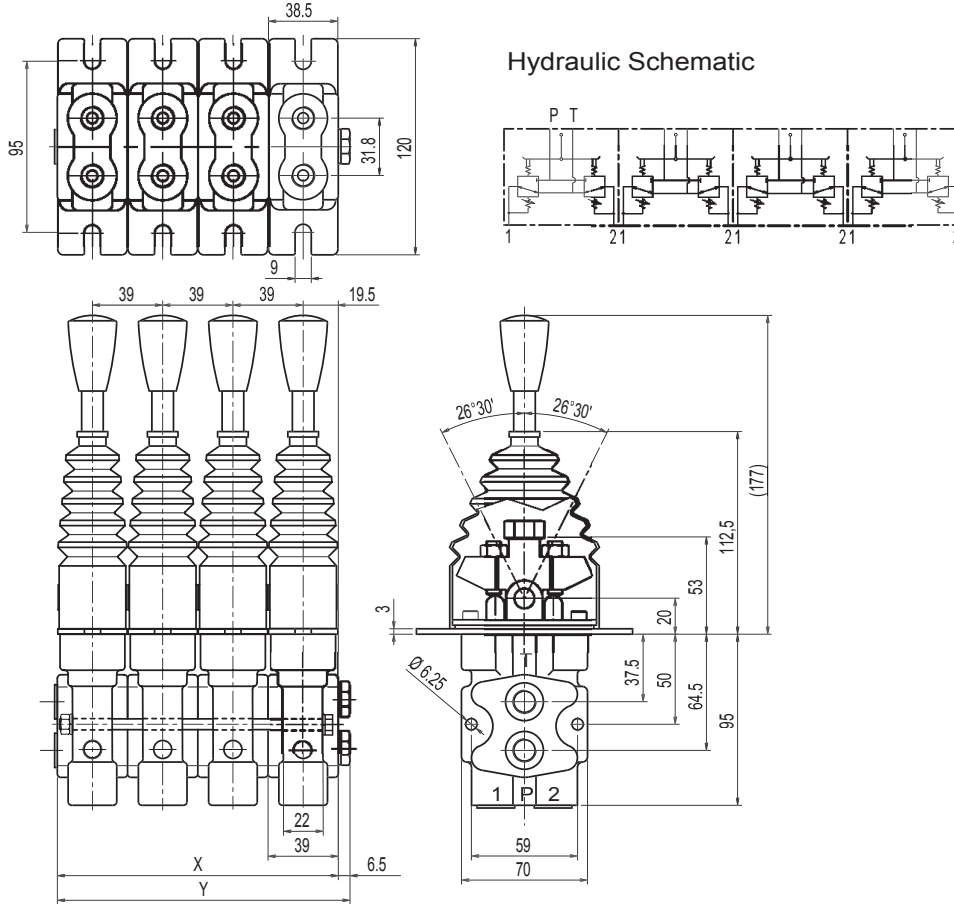

Variable dimensions

HC-RCM	/1	/2	/3	/4	/5	/6	/7	/8	/9	/10	/11	/12
X (mm)	39	78	117	156	195	234	273	312	351	390	429	468
X (in)	1,5	3,1	4,7	6,3	7,9	9,5	11,1	12,7	14,3	15,9	17,5	19,1
Y (mm)	45,5	84,4	123,5	162,5	201,5	240,5	279,5	318,5	357,5	396,5	435,5	474,5
Y (in)	1,8	3,3	4,9	6,4	7,9	9,5	11	12,5	14,1	15,6	17,2	18,7

Weights

HC-RCM	/1	/2	/3	/4	/5	/6	/7	/8	/9	/10	/11	/12
Kg	1,5	3	4,5	6	7,5	9	10,5	12	13,5	15	16,5	18
lb	3,4	6,7	10	13,3	16,6	19,9	23,2	26,5	29,8	33,1	36,4	39,7

Tie-rod clamping torque	14 Nm
--------------------------------	-------

NOTE: each hydraulic remote control is assembled with N° 2 tie rod kits including a tie rod, two nuts and two washers.

RCM Series

Hydraulic Remote Controls



How To Order

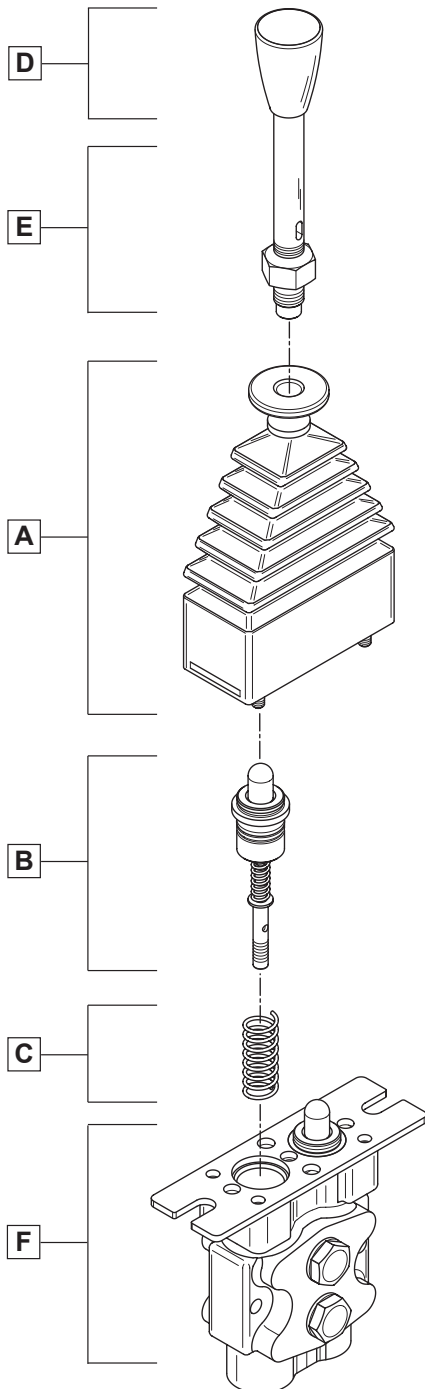
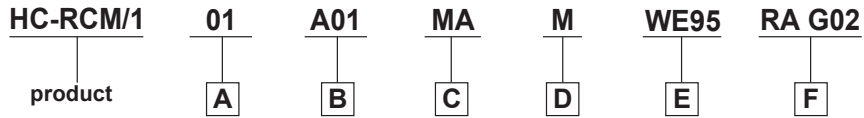

A CONTROL

01 = control type

B METERING CURVE

A01 = curve type

C RETURN SPRING

MA = return spring type

NOTE: ordering row B and C, must be repeated for each port

D HANDLE

M = handle type

E LEVER ROD

WE = lever rod type
95 = lever rod length

F BODY ARRANGEMENT

RA = body specification
G02 = threads

RCM Series

Hydraulic Remote Controls



Controls

CODE	DIAGRAM	OVERALL DIMENSIONS	DESCRIPTION
01			Return spring in neutral position (standard)
02			Stroke end mechanical detent in position 1 and 2
03			Stroke end mechanical detent in position 1
04			Stroke end mechanical detent in position 2
05			Security handle in neutral position
06			Friction

RCM Series

Hydraulic Remote Controls



Metering Curve

CODE	DIAGRAM	OVERALL DIMENSIONS	DESCRIPTION
12			Security handle in neutral with micro-switch open in central position
13			Friction with micro-switch open in central position
14			Stroke end mechanical detent in position 1 and 2, security handle in neutral with micro-switch closed in central position
17			Security handle in neutral with micro-switch closed in central position
18			Friction with micro-switch closed in central position
19			Spring return in neutral with micro-switch open in central position

MICRO-SWITCHES SPECIFICATIONS CURRENT:

Direct current load resistive	5 A 30 VDC
Direct current load inductive.....	3 A 250 VDC
Alternating current load resistive	5 A 30 VAC
Alternating current load inductive	2 A 250 VAC

Metering curve

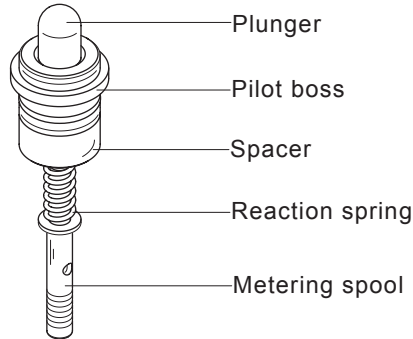

DIAGRAM

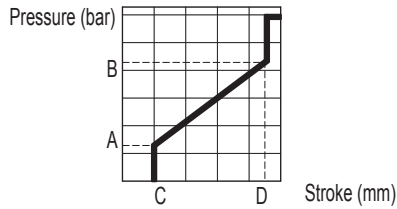

DESCRIPTION

Linear metering curve with step

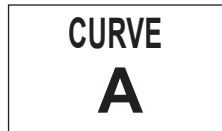

CODE	A01	A02	A03	A04	A05	A06	A07	A08	A09	A10	A11	A12	A13	A14	A15	A16	A17	A18	A19	A20	
PRESSURE	A	5,8	5	2	6	0	4	5	2	5	2	4	11,5	10	7	7,5	6	0	4	6	8
	B	19,5	25	13	40	4	17	15	18	20	8	10	32	20	17	29	22	20	16	20,6	28
STROKE	C	1,5	1,5	1,5	1,5	1,5	1,5	1,5	1,5	1,5	1,5	1,5	1,5	1,5	1,5	1,5	1,5	1	1,5	1,5	1,5
	D	7,5	7,5	7,5	7,5	7,5	7,5	7,5	7,5	6	7,5	7,5	7,5	7,5	7,5	7,5	7,5	7,5	7	7	7,5

CODE	A21	A22	A23	A24	A25	A26	A27	A28	A29	A30	A31	A32	A33	A34	A35	A36					
PRESSURE	A	5	5,8	6,8	5,8	4,5	2,8	8	3	8	5,8	5,7	7	10,8	0	5,8	7,4				
	B	20,5	18,3	23,5	19,2	14,5	20,8	34	16,2	27,6	15,5	25,7	15,5	27,5	28	24	21				
STROKE	C	1,5	1,5	1	1,5	1	1,5	1,5	1,5	1,5	1,5	1,5	1,2	1	1,5	1,5	1,5				
	D	8	8	7,5	9,5	5	10	7,5	7,5	10	7,5	7,5	7,5	7,5	7,5	9,5	7,5				

DIAGRAM

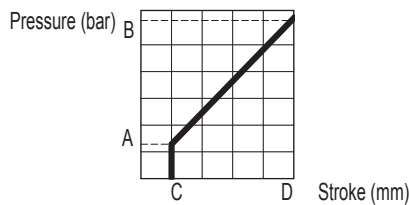

DESCRIPTION

Linear metering curve without step

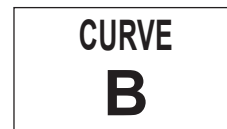

CODE	B01	B02	B03	B04	B05	B06	B07	B08	B09	B10	B11	B12	B13	B14	B15	B16					
PRESSURE	A	5	5	5	2	7,5	5	4	3	6	2	7,2	8,3	8	6	10,4	6,5				
	B	22	19	16	16,5	32,5	20	10,5	14,5	24,3	19,3	21,3	22,4	22,8	23	25,5	12				
STROKE	C	1,5	1,5	1,5	1,5	1	1	1,5	1,5	1	1,5	1	1	1	1,5	1	1				
	D	8	8	8	8	8	8	8	8	8	8	7,5	7,5	7,5	8	7,5	8				

RCM Series

Hydraulic Remote Controls



Metering curve

DIAGRAM

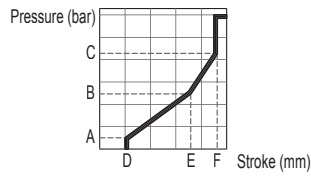

CODE	C01	C02	C03	C04		
PRESSURE	A	2	3	7	7	
	B	6	7	18	18	
	C	15	16	27	27	
STROKE	D	1,5	1,5	0,5	0,5	
	E	5	5	4,8	6,3	
	F	7,5	7,5	6,5	8	

DESCRIPTION

Broke line metering curve with step

CURVE
C

DIAGRAM

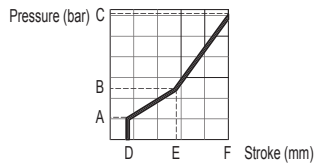

CODE	D01				
PRESSURE	A	2			
	B	6			
	C	15			
STROKE	D	1,5			
	E	5			
	F	8			

DESCRIPTION

Broke line metering curve without step

CURVE
D

Return spring

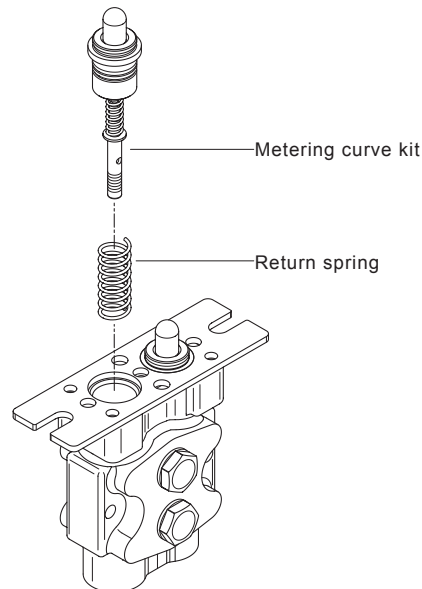

CODE	MA	MB	MC	MD
Preload	29,5 N	14,6 N	73,5 N	98 N
	3 kgf	1,4 kgf	7,5 kgf	10 kgf
End stroke load	44 N	29,4 N	135,5 N	186 N
	4,5 kgf	2,8 kgf	13,8 kgf	19 kgf

RCM Series

Hydraulic Remote Controls



Handles

CODE	DIAGRAM	OVERALL DIMENSIONS	DESCRIPTION
A			Without micro-switch (standard)
B			With micro-switch to close
C			With micro-switch to close with detent
D			With dual micro-switch
E			With dual micro-switch to close with detent
M			Handle with lens

**HANDLES MISCROSWITCH
BREAKING BCDE**

- DIRECT CURRENT load resistive 4.8A/30 VDC
- ALTERNATING CURRENT . . load resistive 1.5A/250 VAC
- PROTECTION IP 40

RCM Series

Hydraulic Remote Controls



Handles

CODE	OVERALL DIMENSIONS	DESCRIPTION
F		Ergonomic Handle

Technical specifications

BUTTONS COLOURS:

A **red**

B-C **yellow**

D-E **green**

F-G **grey**

H (push button for safety) **black**

HANDLE PROTECTION **IP 65**

CABLE SECTION **0.5 mm²**

USEFUL CABLE LENGTH **700 mm**

MICRO-SWITCHES SPECIFICATIONS CURRENT:

Direct current load resistive **5 A 30 VDC**

Direct current load inductive **3 A 250 VDC**

Alternating current load resistive **5 A 30 VAC**

Alternating current load inductive **2 A 250 VAC**

How To Order

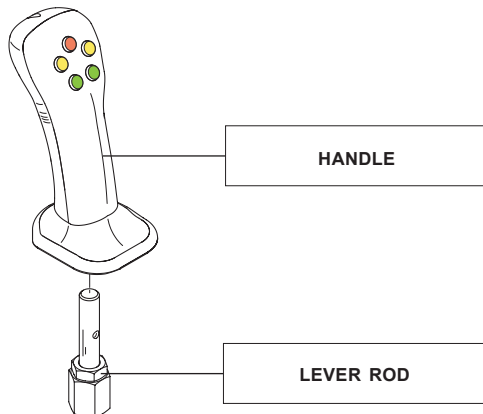

- F** handle type
- 05F** front buttons
- 00R** rear buttons
- 2** handle position
- WF** lever type
- 53** lever rod length

NOTE: handles type **A - B - C - D - E - F** are only available for HC-RCM/1.

RCM Series

Hydraulic Remote Controls



Lever rods for handles type A-B-C-D-E

	OVERALL DIMENSIONS		TO USE ONLY WITH FOLLOWING CONTROLS	
<div style="border: 1px solid black; padding: 5px; width: fit-content;"> CODE WA70 </div>			<div style="border: 1px solid black; padding: 2px; width: 30px; margin-bottom: 5px;">01</div> <div style="border: 1px solid black; padding: 2px; width: 30px; margin-bottom: 5px;">02</div> <div style="border: 1px solid black; padding: 2px; width: 30px; margin-bottom: 5px;">03</div>	<div style="border: 1px solid black; padding: 2px; width: 30px; margin-bottom: 5px;">04</div> <div style="border: 1px solid black; padding: 2px; width: 30px; margin-bottom: 5px;">06</div> <div style="border: 1px solid black; padding: 2px; width: 30px; margin-bottom: 5px;">18</div>

Lever rods for handles type F

	OVERALL DIMENSIONS		TO USE ONLY WITH FOLLOWING CONTROLS	
<div style="border: 1px solid black; padding: 5px; width: fit-content;"> CODE WF90 </div>			<div style="border: 1px solid black; padding: 2px; width: 30px; margin-bottom: 5px;">01</div> <div style="border: 1px solid black; padding: 2px; width: 30px; margin-bottom: 5px;">02</div> <div style="border: 1px solid black; padding: 2px; width: 30px; margin-bottom: 5px;">03</div> <div style="border: 1px solid black; padding: 2px; width: 30px; margin-bottom: 5px;">04</div>	<div style="border: 1px solid black; padding: 2px; width: 30px; margin-bottom: 5px;">06</div> <div style="border: 1px solid black; padding: 2px; width: 30px; margin-bottom: 5px;">13</div> <div style="border: 1px solid black; padding: 2px; width: 30px; margin-bottom: 5px;">18</div>

Lever rods for handles type M

	OVERALL DIMENSIONS		TO USE ONLY WITH FOLLOWING CONTROLS		
<div style="border: 1px solid black; padding: 5px; width: fit-content;"> CODE WE95 </div>			<div style="border: 1px solid black; padding: 2px; width: 30px; margin-bottom: 5px;">01</div> <div style="border: 1px solid black; padding: 2px; width: 30px; margin-bottom: 5px;">02</div> <div style="border: 1px solid black; padding: 2px; width: 30px; margin-bottom: 5px;">03</div>	<div style="border: 1px solid black; padding: 2px; width: 30px; margin-bottom: 5px;">04</div> <div style="border: 1px solid black; padding: 2px; width: 30px; margin-bottom: 5px;">06</div> <div style="border: 1px solid black; padding: 2px; width: 30px; margin-bottom: 5px;">13</div>	<div style="border: 1px solid black; padding: 2px; width: 30px; margin-bottom: 5px;">18</div>
<div style="border: 1px solid black; padding: 5px; width: fit-content;"> CODE WE165 </div>			<div style="border: 1px solid black; padding: 2px; width: 30px; margin-bottom: 5px;">05</div> <div style="border: 1px solid black; padding: 2px; width: 30px; margin-bottom: 5px;">12</div>	<div style="border: 1px solid black; padding: 2px; width: 30px; margin-bottom: 5px;">14</div> <div style="border: 1px solid black; padding: 2px; width: 30px; margin-bottom: 5px;">17</div>	<div style="border: 1px solid black; padding: 2px; width: 30px; margin-bottom: 5px;">19</div>

Body arrangement

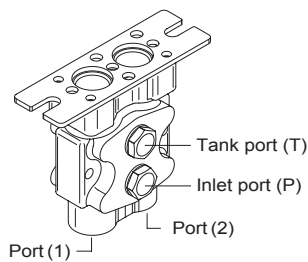

CODE	DESCRIPTION	SERVICE	CODE
RA	Standard body	1/4" BSP	G02
		9/16".18 UNF	U02