

FPMD40DVD2

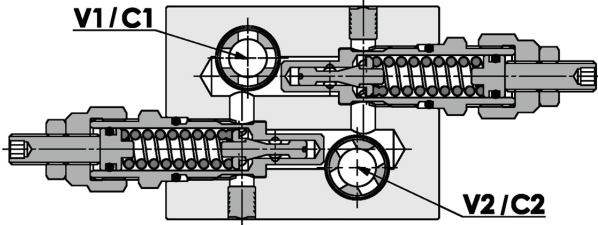

Relief Valves

Features



- FPMD40DVD2 series valves are a dual cross main pressure relief valve, flangeable on Danfoss motors "OMP/OMR" series and White WP/WR series.

- Cartridges are manufactured from zinc plated steel. Internal parts are in hardened steel. Body is in high strength aluminium alloy.

TECHNICAL DATA		
Rated Flow		50 l/min
Max. Setting		350 bar
Max. Pressure		250 bar
Adjustment Means	leakproof screw or handknob (P/R)	
Weight		1.050 Kg

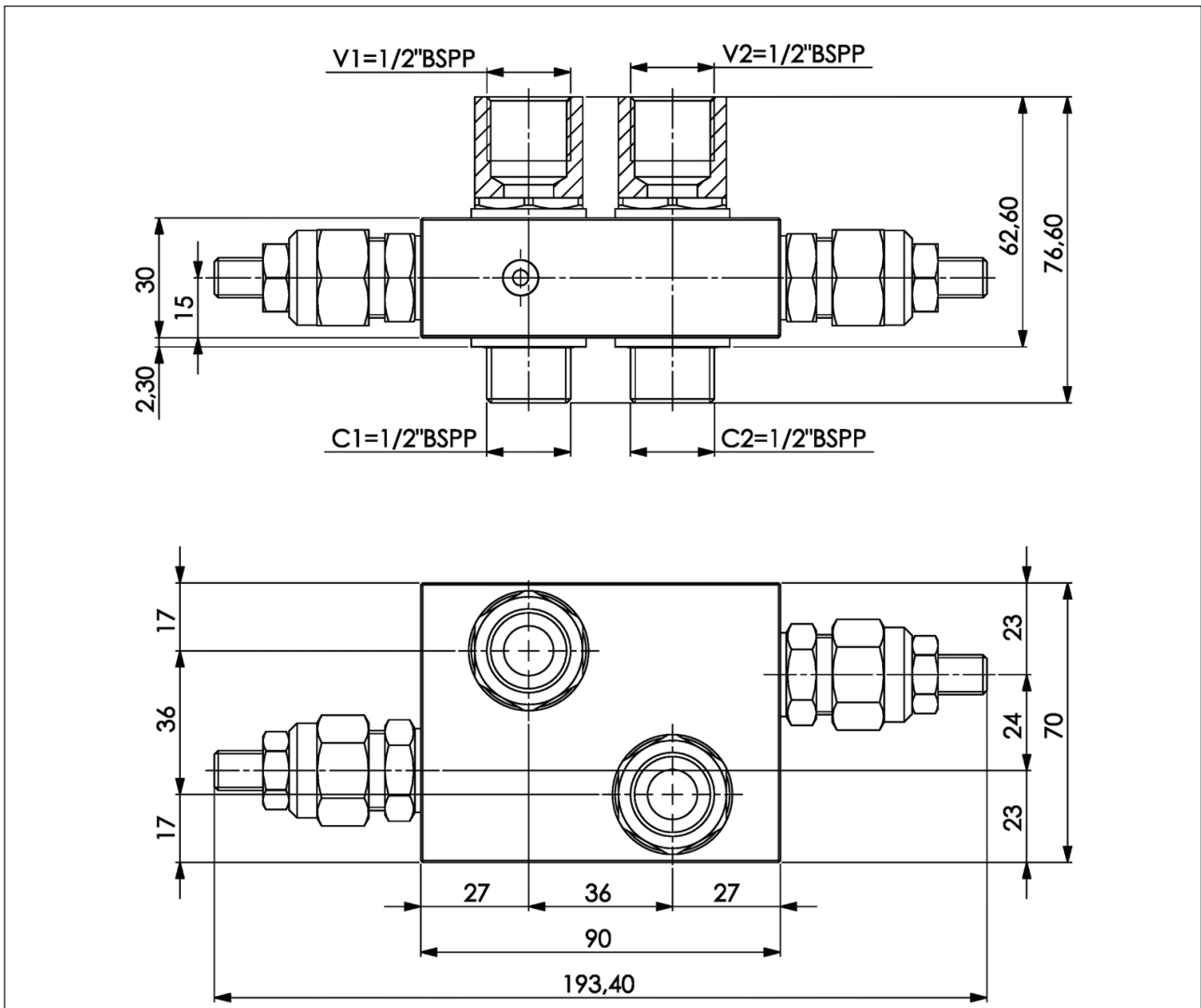
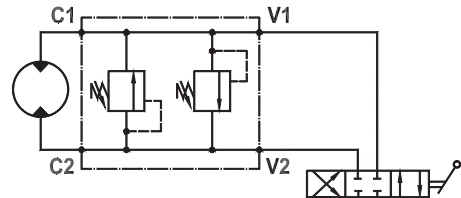



FPMD40DVD2

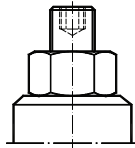
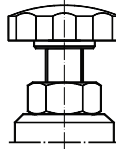

Relief Valves

SPRINGS				
Code *	Adjustable pressure range bar	Pressure increase bar/turn	Standard setting bar	Colour
05	5-50	10	5	White
10	30-100	20	30	Yellow
20	50-220	40	50	Green
35	80-350	80	80	Red

Adjustments		FPM D 40 DV D2
* P	Leakproof hex. socket screw	
* R	Handknob and locknut	
* Z	Tamperproof cap	

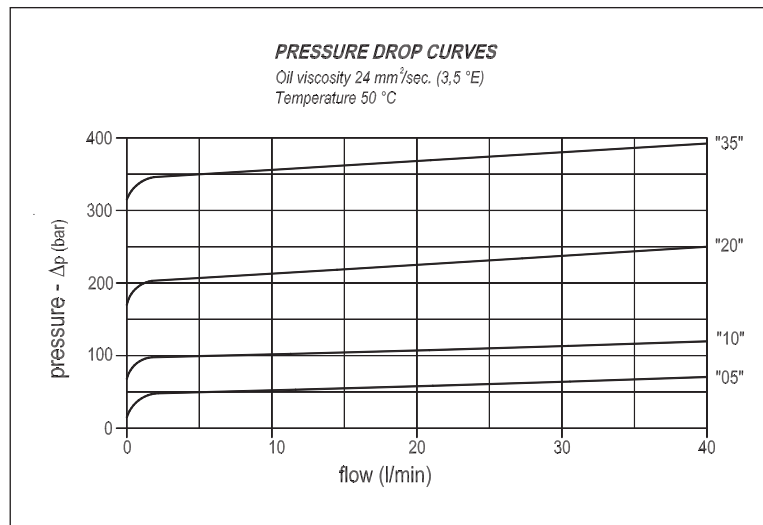
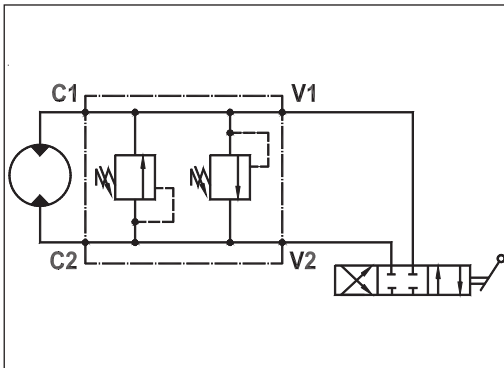

HOW TO ORDER

