

FPMD40DFD2

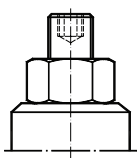
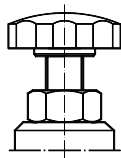
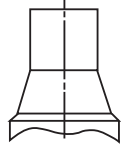

Relief Valves

SPRINGS				
Code *	Adjustable pressure range bar	Pressure increase bar/turn	Standard setting bar	Colour
05	5-50	10	5	White
10	30-100	20	30	Yellow
20	50-220	40	50	Green
35	80-350	80	80	Red

Adjustments		FPM D 40 DF D2
* P	Leakproof hex. socket screw	
* R	Handknob and locknut	
* Z	Tamperproof cap	

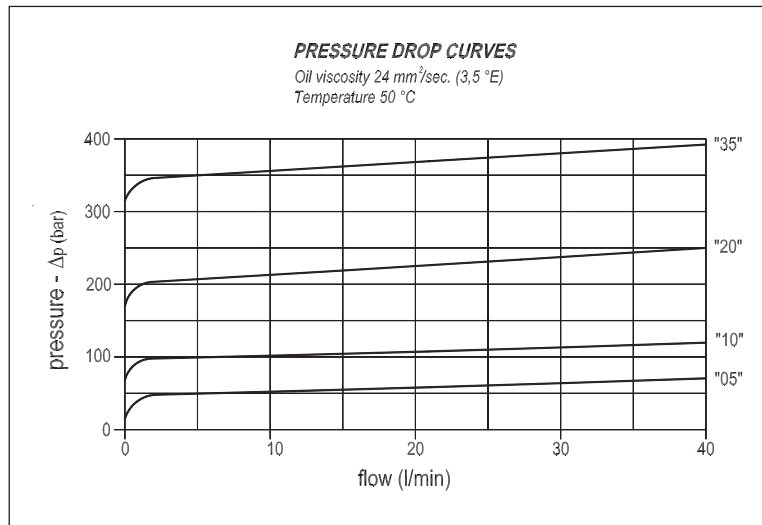
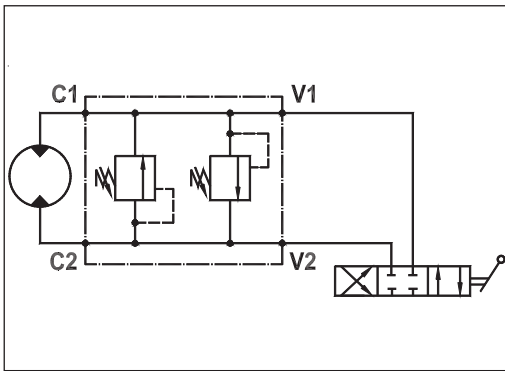

HOW TO ORDER

