

RS (All Series)

For Light Duty Applications

OVERVIEW

RS Series motors are the most economical model in the White Drive Products product line, but are not low-tech. Unlike competitive products using power robbing, two-piece rotor set designs with sliding contact points, RS Series motors utilize the patented Roller Stator® design. Seven precision rollers for the contact points reduce friction, providing more power and longer life for your application. Each output shaft is custom ground to maintain exact tolerances between the housing and shaft, producing high volumetric efficiencies. Industry standard mounting flanges and output shafts allow the RS Series motors to interchange with competitive designs.

FEATURES / BENEFITS

- The shaft is match ground to the housing bore to maintain highest volumetric efficiencies.
- A high pressure shaft seal offers superior seal life and performance and eliminates the need for a case drain.
- Pressure fed bearing surface receives positive flow of clean, cool oil.
- A heavy-duty drive link receives full flow lubrication to provide long life.
- The Roller Stator® motor design increases efficiency and life by using roller contact versus a solid, sliding contact design.

TYPICAL APPLICATIONS

conveyors, carwashes, positioners, light-duty wheel drives, sweepers, food processing, grain augers, spreaders, feed rollers, screw drives, brush drives and more

SERIES DESCRIPTIONS

200/201 - Hydraulic Motor
Standard

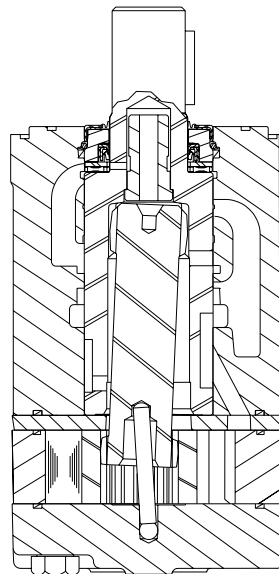

SPECIFICATIONS

CODE	Displacement cm ³ [in ³ /rev]	Max. Speed rpm		Max. Flow lpm [gpm]		Max. Torque Nm [lb-in]		Max. Pressure bar [psi]		
		cont.	inter.	cont.	inter.	cont.	inter.	cont.	inter.	peak
050	52 [3.2]	400	490	23 [6]	38 [10]	82 [730]	95 [840]	121 [1750]	138 [2000]	155 [2250]
080	76 [4.6]	460	540	38 [10]	45 [12]	121 [1070]	138 [1230]	121 [1750]	138 [2000]	155 [2250]
090	89 [5.4]	420	580	38 [10]	45 [12]	147 [1300]	167 [1480]	121 [1750]	138 [2000]	155 [2250]
100	103 [6.3]	510	570	53 [14]	61 [16]	169 [1500]	195 [1725]	121 [1750]	138 [2000]	155 [2250]
110	111 [6.8]	460	600	53 [14]	68 [18]	184 [1630]	214 [1900]	121 [1750]	138 [2000]	155 [2250]
125	127 [7.7]	410	530	53 [14]	68 [18]	181 [1600]	208 [1850]	103 [1500]	121 [1750]	155 [2250]
160	164 [10.0]	370	460	61 [16]	76 [20]	222 [1970]	265 [2350]	103 [1500]	121 [1750]	155 [2250]
200	205 [12.5]	300	370	61 [16]	76 [20]	297 [2640]	345 [3050]	103 [1500]	121 [1750]	155 [2250]
250	254 [15.5]	300	360	76 [20]	91 [24]	287 [2540]	344 [3040]	86 [1250]	104 [1500]	121 [1750]
300	293 [17.9]	300	310	76 [20]	91 [24]	277 [2460]	350 [3100]	69 [1000]	86 [1250]	103 [1500]
400	409 [24.9]	190	220	76 [20]	91 [24]	377 [3350]	463 [4100]	69 [1000]	86 [1250]	103 [1500]

► Performance data is typical. Performance of production units varies slightly from one motor to another. See page 9 for additional information on product testing. Running at intermittent ratings should not exceed 10% of every minute of operation.

RS (All Series)

For Light Duty Applications

DISPLACEMENT PERFORMANCE

		Pressure - bar [psi]							Max. Cont.	Max. Inter.
050		17 [250]	35 [500]	52 [750]	69 [1000]	86 [1250]	104 [1500]	121 [1750]	138 [2000]	
52 cm ³ [3.2 in ³] / rev										
		Torque - Nm [lb-in], Speed rpm							Intermittent Ratings - 10% of Operation	
Flow - lpm [gpm]	Max. Cont.	2 [0.5]	10 [89] 35	15 [133] 33	25 [223] 26	33 [290] 24	42 [375] 24	49 [435] 12		37
		Max. Inter.	4 [1]	10 [92] 69	18 [163] 68	29 [253] 68	39 [348] 67	49 [438] 54	59 [523] 49	55 [483] 4
	8 [2]		10 [90] 142	20 [181] 140	31 [274] 138	41 [366] 136	52 [464] 127	63 [556] 103	74 [653] 78	78 [690] 34
	15 [4]	10 [85] 288	17 [154] 285	28 [251] 283	40 [355] 282	53 [465] 275	65 [572] 258	76 [669] 227	86 [764] 193	289
	23 [6]		19 [168] 433	27 [243] 432	39 [342] 430	50 [445] 429	62 [549] 408	74 [656] 380	85 [755] 346	434
	30 [8]		17 [148] 576	27 [243] 574	36 [318] 570	47 [417] 568	59 [526] 554	71 [631] 535		578
	38 [10]		13 [119] 718	25 [218] 711	35 [307] 701	48 [429] 700	56 [499] 689	67 [593] 682		722
Rotor Width		Overall Efficiency - 70 - 100% <input type="checkbox"/> 40 - 69% <input type="checkbox"/> 0 - 39% <input checked="" type="checkbox"/>								
8.0 [0.316] mm [in]		Theoretical Torque - Nm [lb-in]								
		14 [127]	29 [255]	43 [382]	58 [510]	72 [637]	86 [764]	101 [892]	115 [1019]	
		Displacement tested at 54°C [129°F] with an oil viscosity of 46cSt [213 SUS]								

		Pressure - bar [psi]							Max. Cont.	Max. Inter.
080		17 [250]	35 [500]	52 [750]	69 [1000]	86 [1250]	104 [1500]	121 [1750]	138 [2000]	
76 cm ³ [4.6 in ³] / rev										
		Torque - Nm [lb-in], Speed rpm							Intermittent Ratings - 10% of Operation	
Flow - lpm [gpm]	Max. Cont.	2 [0.5]	12 [107] 25	26 [227] 21	39 [341] 20	51 [456] 9	58 [509] 5			26
		Max. Inter.	4 [1]	12 [110] 50	29 [252] 50	43 [381] 42	59 [522] 35	75 [661] 34	81 [720] 11	
	8 [2]		14 [122] 100	29 [260] 99	46 [405] 99	63 [560] 93	80 [707] 82	96 [848] 73	110 [973] 48	115 [1016] 20
	15 [4]		30 [263] 200	47 [416] 196	65 [574] 193	82 [728] 184	98 [871] 168	118 [1046] 150	134 [1184] 121	201
	23 [6]		28 [252] 301	46 [403] 297	64 [562] 293	82 [721] 287	98 [869] 271	115 [1020] 252	134 [1183] 218	302
	30 [8]		25 [221] 400	43 [379] 399	63 [555] 393	79 [703] 390	97 [860] 375	115 [1014] 355	132 [1172] 330	402
	38 [10]			39 [341] 502	57 [502] 500	74 [657] 498	93 [819] 496	111 [980] 472	128 [1135] 443	503
	45 [12]			35 [314] 602	50 [446] 600	71 [625] 599	92 [816] 598	105 [932] 580		603
Rotor Width		Overall Efficiency - 70 - 100% <input type="checkbox"/> 40 - 69% <input type="checkbox"/> 0 - 39% <input checked="" type="checkbox"/>								
11.7 [0.462] mm [in]		Theoretical Torque - Nm [lb-in]								
		21 [183]	41 [366]	62 [549]	83 [732]	103 [916]	124 [1099]	145 [1282]	166 [1465]	
		Displacement tested at 54°C [129°F] with an oil viscosity of 46cSt [213 SUS]								

		Pressure - bar [psi]							Max. Cont.	Max. Inter.
090		17 [250]	35 [500]	52 [750]	69 [1000]	86 [1250]	104 [1500]	121 [1750]	138 [2000]	
89 cm ³ [5.4 in ³] / rev										
		Torque - Nm [lb-in], Speed rpm							Intermittent Ratings - 10% of Operation	
Flow - lpm [gpm]	Max. Cont.	2 [0.5]	23 [206] 20	43 [376] 19	63 [559] 17	84 [743] 14	98 [864] 10	105 [933] 1		22
		Max. Inter.	4 [1]		43 [383] 41	64 [566] 40	86 [760] 37	108 [953] 32	127 [1123] 25	138 [1225] 12
	8 [2]			44 [388] 85	63 [561] 84	83 [739] 81	106 [937] 75	127 [1121] 66	151 [1336] 51	169 [1495] 31
	15 [4]			61 [538] 169	85 [754] 166	104 [920] 159	128 [1134] 149	148 [1309] 133	168 [1484] 115	172
	23 [6]				81 [720] 251	102 [902] 244	125 [1105] 229	144 [1275] 213	164 [1450] 191	257
	30 [8]				78 [686] 338	98 [867] 330	122 [1080] 318	141 [1251] 300	164 [1448] 278	343
	38 [10]					93 [824] 417	113 [1004] 406	137 [1210] 386	161 [1422] 365	428
	45 [12]					81 [715] 504	87 [766] 491	113 [998] 478		514
Rotor Width		Overall Efficiency - 70 - 100% <input type="checkbox"/> 40 - 69% <input type="checkbox"/> 0 - 39% <input checked="" type="checkbox"/>								
13.7 [0.541] mm [in]		Theoretical Torque - Nm [lb-in]								
		24 [215]	49 [430]	73 [645]	97 [860]	121 [1075]	146 [1290]	170 [1505]	194 [1720]	
		Displacement tested at 54°C [129°F] with an oil viscosity of 46cSt [213 SUS]								

► Performance data is typical. Performance of production units varies slightly from one motor to another. See page 10.03 for additional information on product testing.

RS (All Series) For Light Duty Applications

DISPLACEMENT PERFORMANCE

		Pressure - bar [psi]							Max. Cont.	Max. Inter.
100		17 [250]	35 [500]	52 [750]	69 [1000]	86 [1250]	104 [1500]	121 [1750]	138 [2000]	
103 cm ³ [6.3 in ³] / rev		Torque - Nm [lb-in], Speed rpm							Intermittent Ratings - 10% of Operation	
Flow - lpm [gpm]	2 [0.5]	25 [221] 17	52 [461] 16	76 [676] 15	98 [870] 12	115 [1020] 7				19
	4 [1]	26 [233] 36	51 [449] 36	77 [680] 34	103 [914] 32	126 [1116] 28	146 [1295] 23	166 [1473] 13	151 [1336] 1	37
	8 [2]		49 [433] 72	77 [682] 71	101 [893] 69	125 [1108] 65	150 [1331] 59	174 [1538] 50	199 [1758] 37	74
	15 [4]			73 [648] 143	99 [873] 135	123 [1088] 124	146 [1291] 118	170 [1504] 94	195 [1721] 75	147
	23 [6]			69 [606] 219	94 [830] 213	120 [1062] 203	145 [1279] 190	165 [1463] 177	194 [1717] 154	220
	30 [8]				89 [789] 288	113 [999] 278	142 [1254] 264	161 [1429] 249	187 [1658] 230	294
	38 [10]				78 [693] 363	102 [905] 353	127 [1124] 341	156 [1380] 322	182 [1612] 301	367
	45 [12]					85 [755] 433	119 [1049] 421	147 [1299] 405	172 [1526] 384	440
	53 [14]					84 [746] 507	118 [1040] 497	135 [1198] 484	141 [1250] 465	514
	61 [16]						108 [957] 574	135 [1197] 566		587
Max. Inter. Cont.										
Rotor Width		Overall Efficiency - 70 - 100% <input type="checkbox"/> 40 - 69% <input type="checkbox"/> 0 - 39% <input type="checkbox"/>								
19.7 [.776]		Theoretical Torque - Nm [lb-in]								
mm [in]		28 [251]	57 [502]	85 [752]	113 [1003]	142 [1254]	170 [1505]	198 [1756]	227 [2006]	
Displacement tested at 54°C [129°F] with an oil viscosity of 46cSt [213 SUS]										

		Pressure - bar [psi]							Max. Cont.	Max. Inter.
110		17 [250]	35 [500]	52 [750]	69 [1000]	86 [1250]	104 [1500]	121 [1750]	138 [2000]	
111 cm ³ [6.8 in ³] / rev		Torque - Nm [lb-in], Speed rpm							Intermittent Ratings - 10% of Operation	
Flow - lpm [gpm]	2 [0.5]	26 [227] 16	54 [481] 14	78 [689] 11	100 [888] 7	109 [961] 1				17
	4 [1]	29 [253] 33	55 [489] 32	83 [733] 30	110 [974] 26	134 [1183] 20	153 [1356] 10			34
	8 [2]		57 [503] 67	82 [727] 64	110 [969] 60	135 [1199] 52	162 [1431] 40	184 [1631] 20	180 [1590] 1	68
	15 [4]		54 [479] 135	80 [706] 133	107 [951] 128	134 [1190] 120	162 [1437] 104	186 [1643] 88	216 [1911] 58	136
	23 [6]			76 [669] 201	106 [934] 193	129 [1144] 183	153 [1357] 165	185 [1636] 141	206 [1826] 114	204
	30 [8]			70 [621] 271	97 [862] 267	123 [1092] 256	151 [1336] 242	177 [1569] 220	202 [1788] 196	272
	38 [10]				88 [779] 335	116 [1025] 324	146 [1294] 307	170 [1505] 289	201 [1783] 254	340
	45 [12]				86 [764] 405	109 [963] 396	139 [1226] 376	168 [1482] 351	190 [1683] 330	408
	53 [14]					102 [901] 463	129 [1142] 449	156 [1378] 427	184 [1626] 406	476
	61 [16]					95 [844] 535	121 [1075] 523	147 [1297] 505		544
68 [18]						111 [984] 595	136 [1205] 579		612	
Max. Inter. Cont.										
Rotor Width		Overall Efficiency - 70 - 100% <input type="checkbox"/> 40 - 69% <input type="checkbox"/> 0 - 39% <input type="checkbox"/>								
17.3 [.681]		Theoretical Torque - Nm [lb-in]								
mm [in]		31 [271]	61 [541]	92 [812]	122 [1083]	153 [1354]	184 [1624]	214 [1895]	245 [2166]	
Displacement tested at 54°C [129°F] with an oil viscosity of 46cSt [213 SUS]										

► Performance data is typical. Performance of production units varies slightly from one motor to another. See page 10.03 for additional information on product testing.

RS Series

Light Duty Hydraulic Motor



RS (All Series)

For Light Duty Applications

DISPLACEMENT PERFORMANCE

		Pressure - bar [psi]						Max. Cont.	Max. Inter.
125		17 [250]	35 [500]	52 [750]	69 [1000]	86 [1250]	104 [1500]	121 [1750]	
127 cm ³ [7.7 in ³] / rev									
		Torque - Nm [lb-in], Speed rpm						Intermittent Ratings - 10% of Operation	
Flow - lpm [gpm]	2 [0.5]	29 [225] 14	60 [534] 12	86 [758] 10	112 [990] 7	129 [1145] 2			15
	4 [1]	28 [251] 29	62 [545] 28	93 [819] 26	121 [1073] 23	149 [1319] 18	173 [1531] 10	176 [1559] 1	30
	8 [2]		61 [537] 58	92 [816] 57	125 [1103] 54	153 [1356] 49	182 [1609] 41	210 [1856] 29	60
	15 [4]		61 [538] 118	90 [797] 115	123 [1084] 108	151 [1338] 99	181 [1602] 84	210 [1860] 65	120
	23 [6]			87 [771] 177	117 [1032] 168	149 [1321] 158	177 [1566] 145	208 [1838] 123	180
	30 [8]			82 [722] 234	112 [987] 229	142 [1257] 215	175 [1548] 203	201 [1781] 186	240
	38 [10]				105 [927] 290	137 [1214] 277	167 [1474] 263	194 [1720] 244	300
	45 [12]				97 [859] 349	120 [1066] 339	157 [1386] 322	183 [1622] 306	360
	53 [14]				89 [787] 409	119 [1051] 385	146 [1295] 376	174 [1536] 367	420
	61 [16]					99 [879] 471	131 [1163] 459		480
Max. Cont.									
Max. Inter.					100 [885] 528	119 [1053] 512			540
		Overall Efficiency - 70 - 100% <input type="checkbox"/> 40 - 69% <input type="checkbox"/> 0 - 39% <input checked="" type="checkbox"/>							
		Theoretical Torque - Nm [lb-in]							
Rotor Width		35 [307]						69 [613]	
19.7 [.776]		104 [920]						139 [1226]	
mm [in]		173 [1533]						208 [1839]	
		242 [2146]							
		Displacement tested at 54°C [129°F] with an oil viscosity of 46cSt [213 SUS]							

		Pressure - bar [psi]						Max. Cont.	Max. Inter.
160		17 [250]	35 [500]	52 [750]	69 [1000]	86 [1250]	104 [1500]	121 [1750]	
164 cm ³ [10.0 in ³] / rev									
		Torque - Nm [lb-in], Speed rpm						Intermittent Ratings - 10% of Operation	
Flow - lpm [gpm]	2 [0.5]	32 [281] 11	71 [630] 10	103 [908] 8	141 [1247] 6	167 [1481] 2			12
	4 [1]	35 [308] 22	76 [677] 21	111 [983] 20	141 [1245] 20	182 [1615] 16	211 [1867] 11	234 [2070] 3	24
	8 [2]	36 [320] 45	78 [694] 45	116 [1023] 44	159 [1403] 42	193 [1707] 39	223 [1974] 34	257 [2279] 27	47
	15 [4]		72 [633] 91	114 [1007] 90	155 [1375] 86	190 [1679] 80	226 [1998] 71	262 [2319] 56	93
	23 [6]		69 [608] 138	109 [961] 137	149 [1318] 132	188 [1667] 125	224 [1979] 114	267 [2359] 101	139
	30 [8]		65 [573] 184	104 [921] 183	139 [1233] 180	181 [1597] 171	219 [1941] 161	258 [2284] 148	185
	38 [10]			95 [837] 230	134 [1184] 229	173 [1531] 221	212 [1874] 211	251 [2220] 197	231
	45 [12]			83 [736] 276	124 [1095] 275	162 [1432] 270	203 [1796] 259	241 [2133] 245	278
	53 [14]			73 [643] 322	114 [1010] 321	154 [1366] 320	194 [1714] 310	231 [2045] 295	324
	61 [16]				102 [901] 369	142 [1255] 368	179 [1585] 362	219 [1936] 345	370
Max. Cont.									
Max. Inter.				93 [824] 415	127 [1121] 414	164 [1447] 410			416
		Overall Efficiency - 70 - 100% <input type="checkbox"/> 40 - 69% <input type="checkbox"/> 0 - 39% <input checked="" type="checkbox"/>							
		Theoretical Torque - Nm [lb-in]							
Rotor Width		45 [398]						90 [796]	
25.4 [1.000]		135 [1194]						180 [1592]	
mm [in]		225 [1990]						270 [2389]	
		315 [2787]							
		Displacement tested at 54°C [129°F] with an oil viscosity of 46cSt [213 SUS]							

► Performance data is typical. Performance of production units varies slightly from one motor to another. See page 10.03 for additional information on product testing.

RS Series

Light Duty Hydraulic Motor



RS (All Series) For Light Duty Applications

DISPLACEMENT PERFORMANCE

		Pressure - bar [psi]			Max. Cont.	Max. Inter.		
300		17 [250]	35 [500]	52 [750]	69 [1000]	86 [1250]		
293 cm ³ [17.9 in ³] / rev		Torque - Nm [lb-in], Speed rpm			Intermittent Ratings - 10% of Operation			
Flow - lpm [gpm]	2 [0.5]	58 [516] 5	126 [1111] 5	185 [1638] 5				7
	4 [1]	64 [563] 12	124 [1096] 12	189 [1673] 11	263 [2325] 10	329 [2912] 9		13
	8 [2]	64 [564] 25	133 [1180] 25	199 [1758] 24	268 [2375] 23	343 [3033] 21		26
	15 [4]	59 [524] 51	135 [1193] 51	200 [1773] 50	269 [2384] 50	355 [3145] 47		52
	23 [6]	53 [468] 76	126 [1116] 76	195 [1728] 75	278 [2463] 75	350 [3096] 74		78
	30 [8]		108 [954] 102	186 [1650] 101	251 [2218] 101	339 [3000] 100		104
	38 [10]		100 [887] 128	170 [1503] 128	241 [2132] 127	319 [2824] 126		130
	45 [12]		79 [698] 154	156 [1381] 154	220 [1944] 153	301 [2660] 152		155
	53 [14]		63 [558] 180	136 [1206] 180	201 [1780] 179	284 [2512] 179		181
	61 [16]			113 [1000] 205	184 [1630] 204	250 [2213] 203		207
	68 [18]				156 [1382] 231	216 [1915] 230		233
	76 [20]				119 [1054] 257	190 [1679] 256		259
	83 [22]				83 [738] 283			284
	91 [24]							310
Rotor Width								
45.5 [1.790] mm [in]								
		Theoretical Torque - Nm [lb-in]						
		81 [713]	161 [1425]	242 [2138]	322 [2850]	403 [3563]		
Displacement tested at 54°C [129°F] with an oil viscosity of 46cSt [213 SUS]								

		Pressure - bar [psi]			Max. Cont.	Max. Inter.		
400		17 [250]	35 [500]	52 [750]	69 [1000]	86 [1250]		
409 cm ³ [24.9 in ³] / rev		Torque - Nm [lb-in], Speed rpm			Intermittent Ratings - 10% of Operation			
Flow - lpm [gpm]	2 [0.5]	87 [767] 3	187 [1656] 2					5
	4 [1]	90 [793] 8	180 [1597] 8	274 [2425] 6	369 [3270] 6	446 [3951] 3		10
	8 [2]	88 [777] 18	175 [1550] 17	286 [2528] 16	374 [3309] 15	466 [4124] 12		19
	15 [4]	85 [753] 37	177 [1565] 36	287 [2540] 35	382 [3384] 33	469 [4153] 29		38
	23 [6]	71 [631] 55	169 [1498] 55	280 [2477] 54	370 [3273] 52	466 [4122] 49		56
	30 [8]	58 [516] 73	158 [1396] 71	257 [2274] 70	352 [3119] 69	441 [3901] 68		75
	38 [10]		141 [1247] 92	238 [2103] 91	328 [2906] 90	434 [3837] 87		93
	45 [12]		118 [1042] 110	225 [1989] 109	303 [2682] 108	408 [3613] 107		112
	53 [14]		89 [792] 129	189 [1670] 128	278 [2463] 126	367 [3251] 124		130
	61 [16]		59 [520] 147	154 [1359] 146	249 [2204] 144	334 [2954] 143		149
	68 [18]			116 [1027] 166	219 [1934] 165	320 [2746] 164		167
	76 [20]			89 [790] 185	188 [1663] 184	264 [2336] 183		186
	83 [22]				140 [1242] 204			205
	91 [24]				93 [824] 222			223
Rotor Width								
63.5 [2.500] mm [in]								
		Theoretical Torque - Nm [lb-in]						
		112 [991]	224 [1982]	336 [2974]	448 [3965]	560 [4956]		
Displacement tested at 54°C [129°F] with an oil viscosity of 46cSt [213 SUS]								

► Performance data is typical. Performance of production units varies slightly from one motor to another. See page 10.03 for additional information on product testing.

RS (200/201 Series) Light Duty Hydraulic Motor

HOUSINGS

► Dimensions shown are without paint. Paint thickness can be up to 0.13 [.005].

2-HOLE, SAE A MOUNT, ALIGNED PORTS

A10 1/2-14 NPT **A11** 7/8-14 UNF **A18** G 1/2 **A68** G 1/2 (TP)

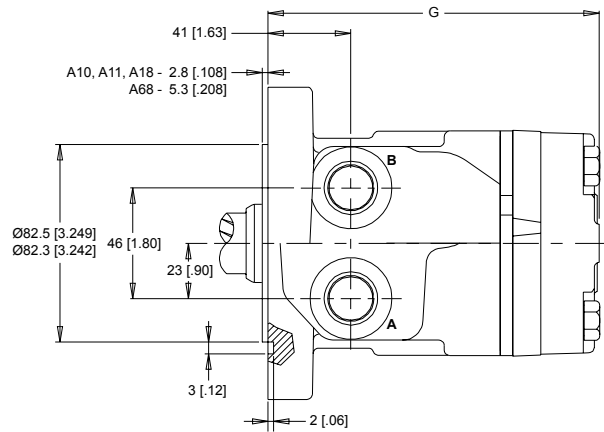
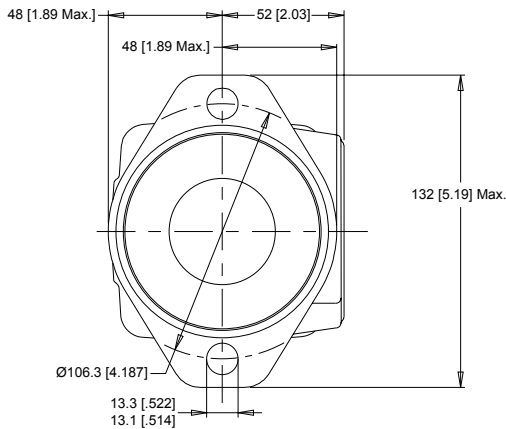

2-HOLE, SAE A MOUNT, OFFSET PORTS

A12 G 1/2 **A62** G 1/2 (TP)

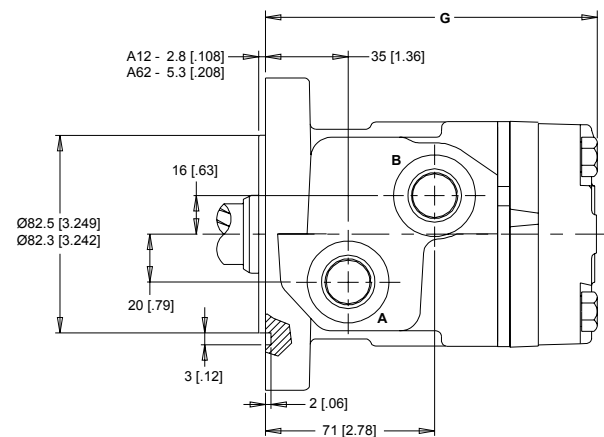
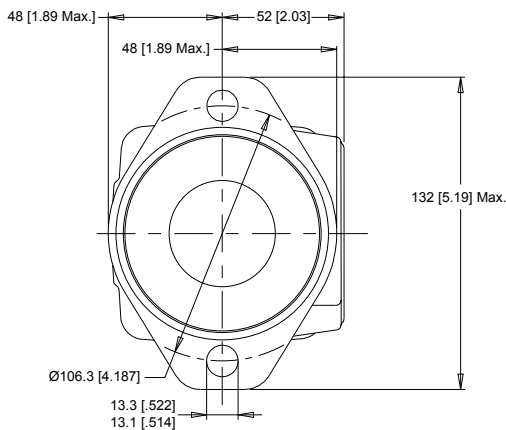

2-HOLE, SAE A MOUNT, ALIGNED MANIFOLD PORTS

A17 1/2" Drilled **A67** 1/2" Drilled (TP)

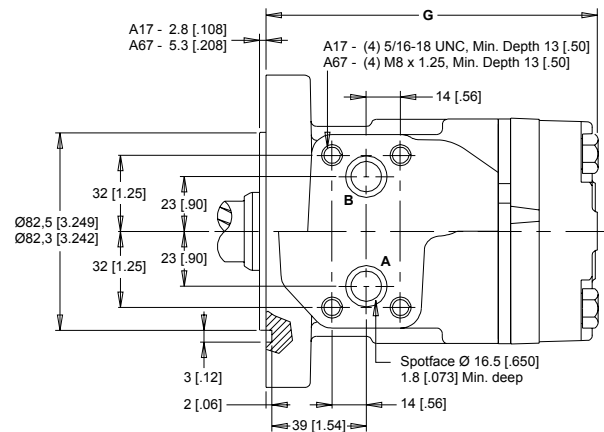
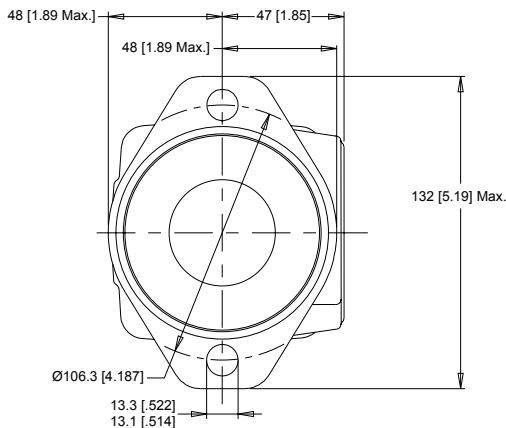

► Dimension G is charted on page 10.45. ► (TP) - Taller Pilot Height. Refer to detailed drawing for dimensional differences.

RS (200/201 Series) Light Duty Hydraulic Motor

HOUSINGS

► Dimensions shown are without paint. Paint thickness can be up to 0.13 [.005].

2-HOLE, SAE A MOUNT, OFFSET MANIFOLD PORTS

A13 G 1/2

A63 G 1/2 (TP)

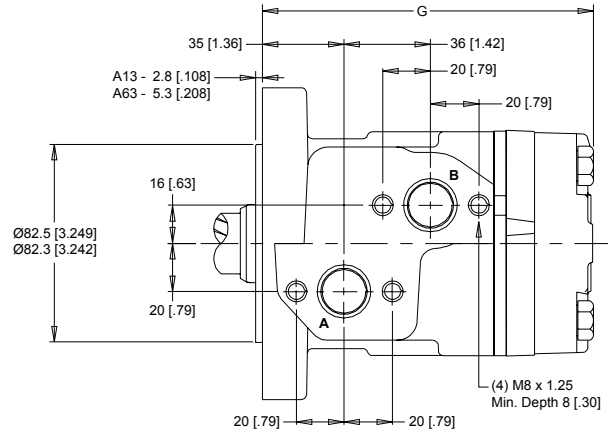
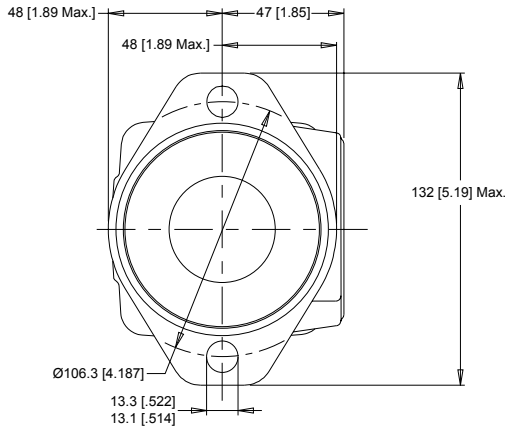

2-HOLE, SAE A MOUNT, SIDE PORTS

A70 1/2-14 NPT

A71 7/8-14 UNF

A78 G 1/2

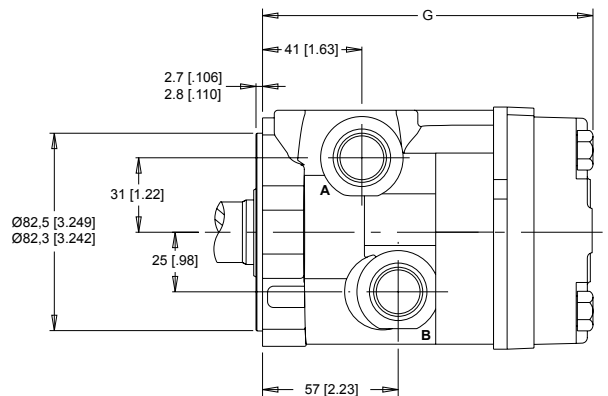
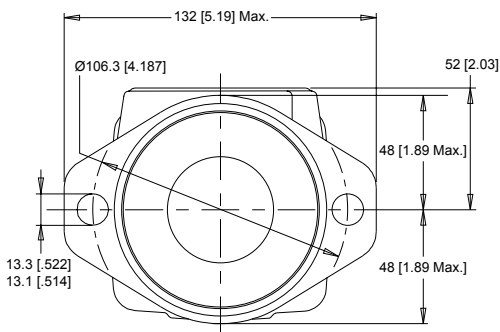

2-HOLE, SAE A MOUNT, OFFSET PORTS, VALVE CAVITY

A19 7/8-14 UNF

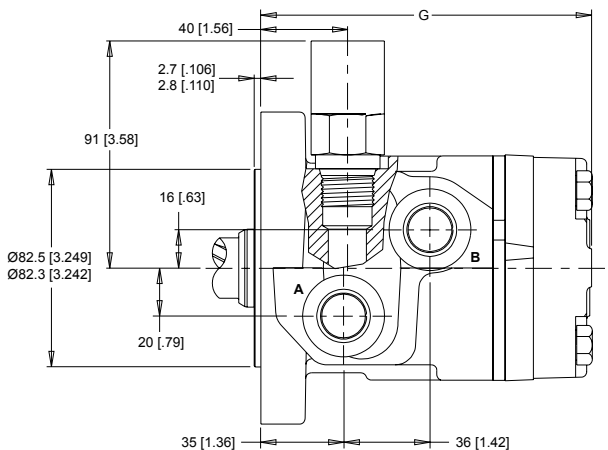
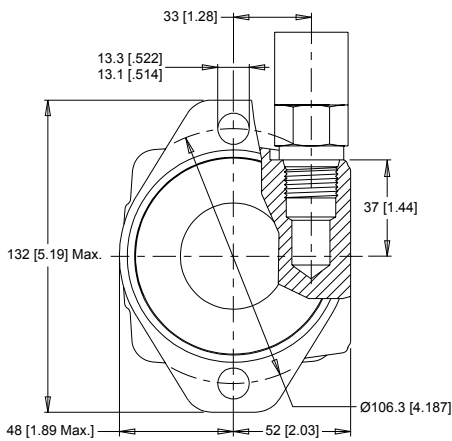

► Dimension G is charted on page 10.45. ► (TP) - Taller Pilot Height. Refer to detailed drawing for dimensional differences.

RS Series

Light Duty Hydraulic Motor



RS (200/201 Series) Light Duty Hydraulic Motor

HOUSINGS

► Dimensions shown are without paint. Paint thickness can be up to 0.13 [0.05].

4-HOLE, SQUARE MOUNT, ALIGNED PORTS

F30 1/2-14 NPT **F31** 7/8-14 UNF

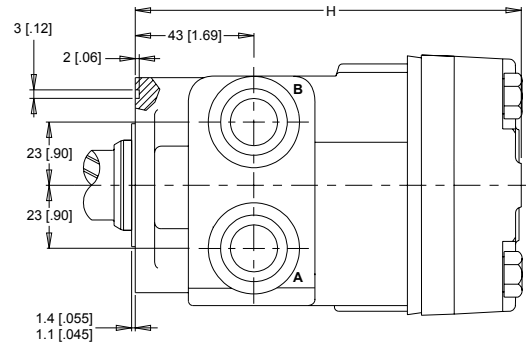
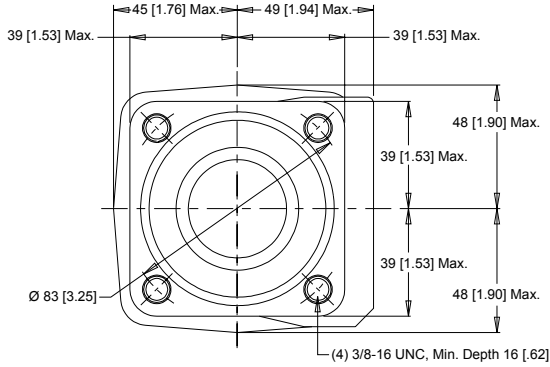

4-HOLE, SQUARE MOUNT, ALIGNED MANIFOLD PORTS

F37 1/2" Drilled

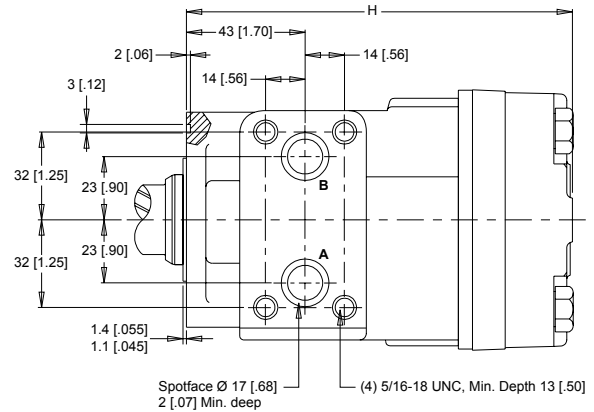
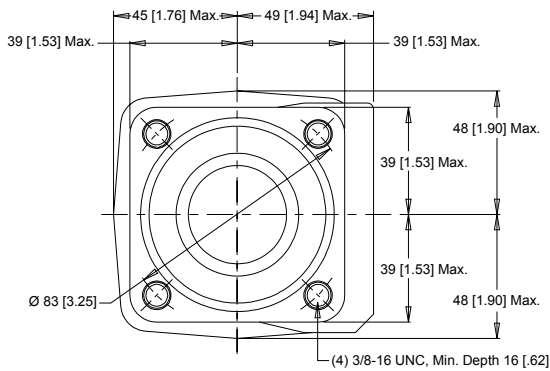

4-HOLE, SQUARE MOUNT, OFFSET MANIFOLD PORTS, VALVE CAVITY

F39 7/8-14 UNF

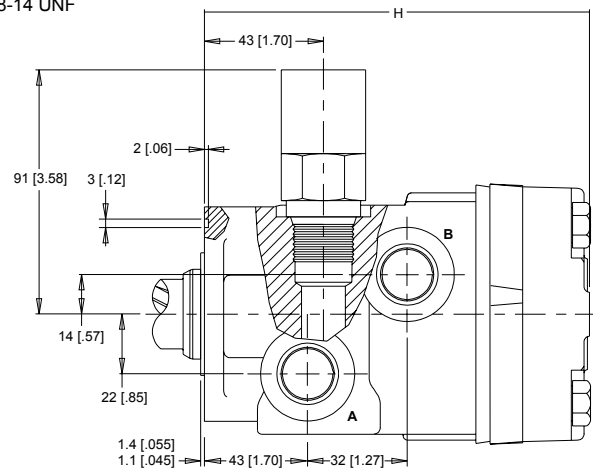
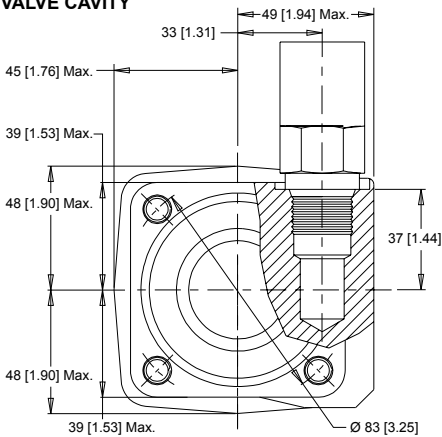

► Dimension H is charted on page 10.45.

RS Series

Light Duty Hydraulic Motor



RS (200/201 Series) Light Duty Hydraulic Motor

HOUSINGS

► Dimensions shown are without paint. Paint thickness can be up to 0.13 [.005].

2-HOLE, SAE B MOUNT, ALIGNED PORTS

B10 1/2-14 NPT **B11** 7/8-14 UNF **B18** G 1/2

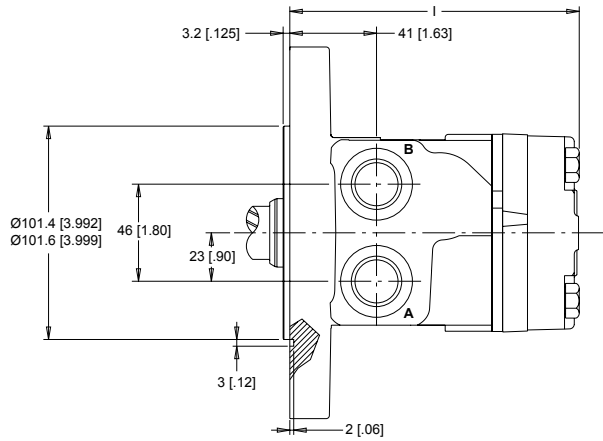
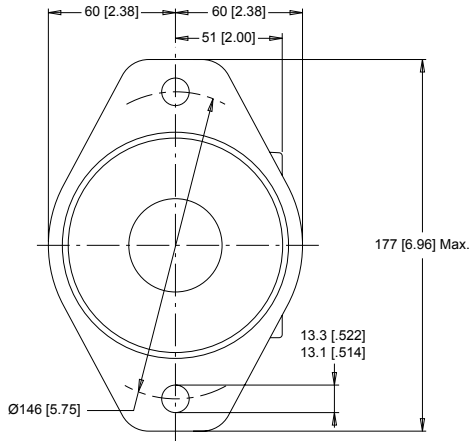

2-HOLE, SAE B MOUNT, SIDE PORTS

B70 1/2-14 NPT **B71** 7/8-14 UNF **B78** G 1/2

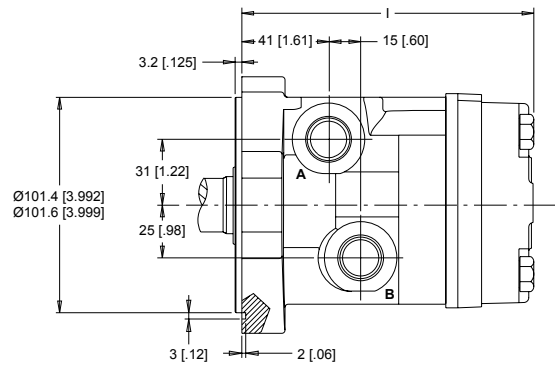
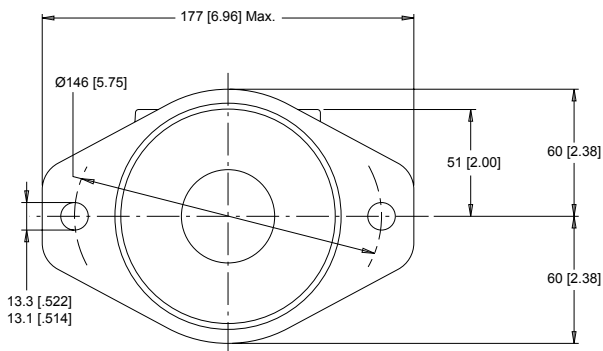

► Dimension I is charted on page 10.45.

RS Series

Light Duty Hydraulic Motor



RS (200/201 Series) Light Duty Hydraulic Motor

TECHNICAL INFORMATION

ALLOWABLE SHAFT LOAD / BEARING CURVE

The bearing curve below represents the side load capacity of the motor at the centerline of the key for various motor speeds. Operating conditions within the shaded area will maintain acceptable oil film lubrication with recommended fluids. Operating conditions outside the shaded area are susceptible to motor failure due to oil starvation and/or excessive heat generation. Fluids with low lubricity or low viscosity may require the maximum load and speed ratings to be derated to provide acceptable motor life and performance.

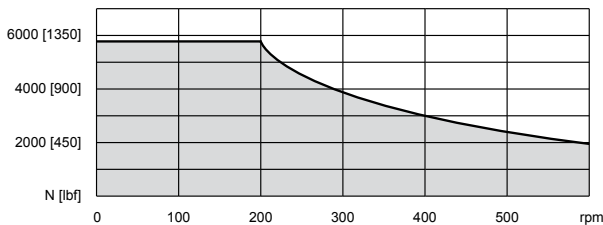

THRUST LOAD

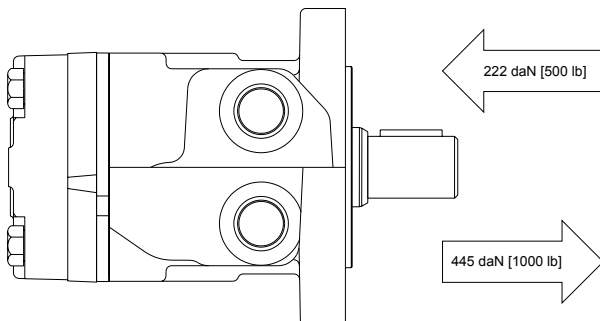

LENGTH & WEIGHT CHARTS

► 200 & 201 series motor weights can vary ± 0.5 kg [1 lb] depending on model configurations such as housing, shaft, endcover, options etc.

Dimension G is the overall motor length from the rear of the motor to the mounting flange surface and is referenced on detailed housing drawings listed on pages 10.41-10.42.

G	Length	Weight
#	mm [in]	kg [lb]
050	134 [5.29]	7.3 [16.1]
080	138 [5.44]	7.5 [16.5]
090	140 [5.51]	7.6 [16.8]
100	146 [5.75]	8.0 [17.7]
110	144 [5.65]	7.8 [17.2]
125	146 [5.75]	8.0 [17.7]
160	152 [5.97]	8.3 [18.2]
200	158 [6.22]	8.5 [18.8]
250	166 [6.53]	9.0 [19.8]
300	172 [6.76]	9.3 [20.5]
400	190 [7.47]	10.3 [22.7]

Dimension H is the overall motor length from the rear of the motor to the mounting flange surface and is referenced on detailed housing drawings listed on page 10.43.

H	Length	Weight
#	mm [in]	kg [lb]
050	136 [5.36]	6.1 [13.4]
080	140 [5.50]	6.3 [13.9]
090	142 [5.58]	6.4 [14.1]
100	148 [5.82]	6.9 [15.1]
110	145 [5.72]	6.6 [14.6]
125	148 [5.82]	6.9 [15.1]
160	153 [6.04]	7.0 [15.4]
200	160 [6.29]	7.3 [16.0]
250	167 [6.59]	7.8 [17.1]
300	173 [6.83]	8.1 [17.9]
400	192 [7.54]	9.2 [20.2]

Dimension I is the overall motor length from the rear of the motor to the mounting flange surface and is referenced on detailed housing drawings listed on page 10.44.

I	Length	Weight
#	mm [in]	kg [lb]
050	134 [5.29]	8.5 [18.6]
080	138 [5.44]	8.6 [19.0]
090	140 [5.51]	8.8 [19.3]
100	146 [5.75]	9.2 [20.2]
110	144 [5.65]	8.9 [19.7]
125	146 [5.75]	9.2 [20.2]
160	152 [5.97]	9.4 [20.7]
200	158 [6.22]	9.7 [21.3]
250	166 [6.53]	10.1 [22.3]
300	172 [6.76]	10.5 [23.0]
400	190 [7.47]	11.5 [25.2]

RS (200/201 Series) Light Duty Hydraulic Motor

SHAFTS

01 7/8" 13 Tooth Spline

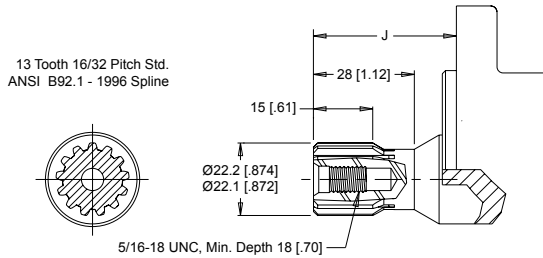

Max. Torque: 170 Nm [1500 lb-in]

02 1" 6B Spline

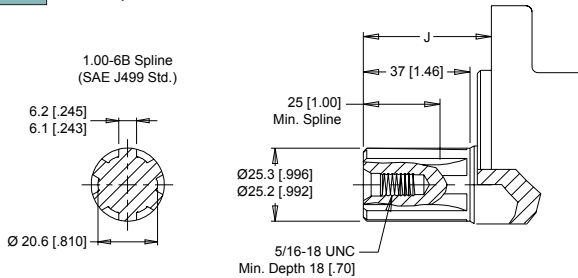

Max. Torque: 678 Nm [6000 lb-in]

05 1" - 9.5 [.375] Pinhole

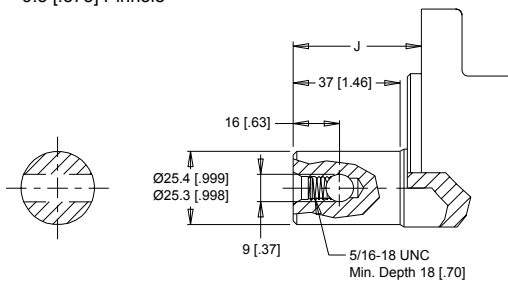

Max. Torque: 678 Nm [6000 lb-in]

10 1" Straight

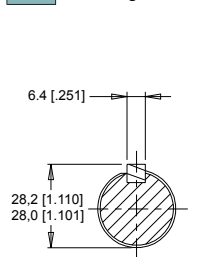

Max. Torque: 655 Nm [5800 lb-in]

15 1" Straight Extended

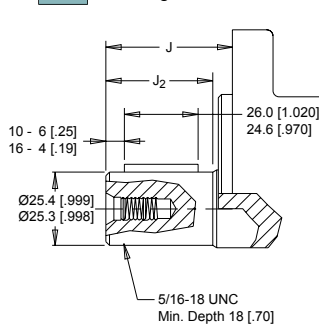

12 25mm Straight

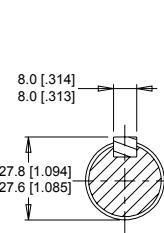

Max. Torque: 678 Nm [6000 lb-in]

16 25mm Straight Extended

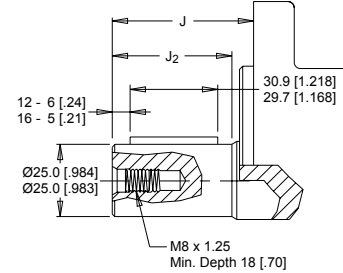

Max. Torque: 678 Nm [6000 lb-in]

13 1" Tapered

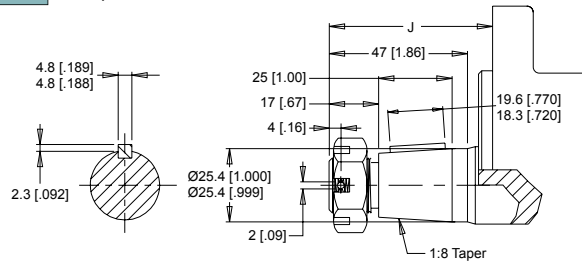

Max. Torque: 655 Nm [5800 lb-in]

▶ A slotted hex nut is standard on this shaft. Dimensional details & additional options are listed on page 14.

MOUNTING / SHAFT LENGTH CHART

Dimension J is the overall distance from the motor mounting surface to the end of the shaft.

Additional shaft length information, if necessary, is noted as J₂ and does not increase or decrease the listed J dimensions in this chart. The overall shaft lengths are already factored into the overall distance from the mounting surface to the end of the shaft.

J	SAE A & B Mounts	Square Mounts	J ₂
#	mm [in]	mm [in]	mm [in]
01	42 [1.65]	40 [1.58]	N/A
02	45 [1.76]	43 [1.69]	N/A
05	45 [1.76]	43 [1.69]	N/A
10	45 [1.76]	43 [1.69]	37 [1.46]
12	55 [2.16]	53 [2.09]	43 [1.70]
13	57 [2.23]	55 [2.16]	N/A
15	58 [2.29]	56 [2.22]	51 [1.99]
16	58 [2.29]	56 [2.22]	50 [1.98]

RS (200/201 Series)

Light Duty Hydraulic Motor

ORDERING INFORMATION

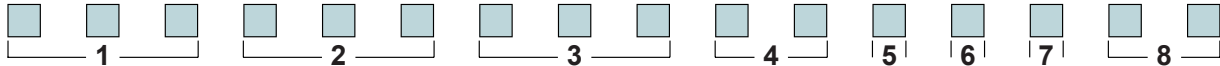

1. CHOOSE SERIES DESIGNATION

200 Clockwise Rotation

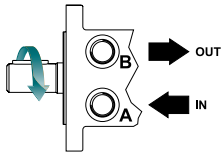

201 Counterclockwise Rotation

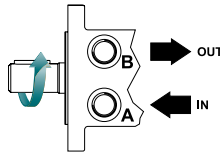

► The 200 & 201 series are bi-directional. Reversing the inlet hose will reverse shaft rotation. For applications requiring the motor to rotate in only one direction, shaft seal life may be prolonged by pressurizing the B port of the motor.

2. SELECT A DISPLACEMENT OPTION

050	52 cm ³ /rev [3.2 in ³ /rev]	160	164 cm ³ /rev [10.0 in ³ /rev]
080	76 cm ³ /rev [4.6 in ³ /rev]	200	205 cm ³ /rev [12.5 in ³ /rev]
090	89 cm ³ /rev [5.4 in ³ /rev]	250	254 cm ³ /rev [15.5 in ³ /rev]
100	103 cm ³ /rev [6.3 in ³ /rev]	300	293 cm ³ /rev [17.9 in ³ /rev]
110	111 cm ³ /rev [6.8 in ³ /rev]	400	409 cm ³ /rev [24.9 in ³ /rev]
125	127 cm ³ /rev [7.7 in ³ /rev]		

3. SELECT A MOUNT & PORT OPTION

A10	2-Hole, SAE A Mount, Aligned Ports, 1/2-14 NPT
A11	2-Hole, SAE A Mount, Aligned Ports, 7/8-14 UNF
A12	2-Hole, SAE A Mount, Offset Ports, G 1/2
A13	2-Hole, SAE A Mount, Offset Manifold Ports, G 1/2
A17	2-Hole, SAE A Mount, Aligned Manifold Ports, 1/2" Drilled
A18	2-Hole, SAE A Mount, Aligned Ports, G 1/2
A19	2-Hole, SAE A Mount, Offset Ports, Valve Cavity 7/8-14 UNF
A62	2-Hole, SAE A Mount, Offset Ports, G 1/2 (TP)
A63	2-Hole, SAE A Mount, Offset Manifold Ports, G 1/2 (TP)
A67	2-Hole, SAE A Mount, Aligned Manifold Ports, 1/2" Drilled (TP)
A68	2-Hole, SAE A Mount, Aligned Ports, G 1/2 (TP)
A70	2-Hole, SAE A Mount, Side Ports, 1/2-14 NPT
A71	2-Hole, SAE A Mount, Side Ports, 7/8-14 UNF
A78	2-Hole, SAE A Mount, Side Ports, G 1/2
B10	2-Hole, SAE B Mount, Aligned Ports, 1/2-14 NPT
B11	2-Hole, SAE B Mount, Aligned Ports, 7/8-14 UNF
B18	2-Hole, SAE B Mount, Aligned Ports, G 1/2
B70	2-Hole, SAE B Mount, Side Ports, 1/2-14 NPT

► (TP) - Tall pilot, refer to pages 59-60 for dimensional differences. Speed sensor option is not available on housings with a tall pilot or SAE B mounts.

3. SELECT A MOUNT & PORT OPTION

B71	2-Hole, SAE B Mount, Side Ports, 7/8-14 UNF
B78	2-Hole, SAE B Mount, Side Ports, G 1/2
F30	4-Hole, Square Mount, Aligned Ports, 1/2-14 NPT
F31	4-Hole, Square Mount, Aligned Ports, 7/8-14 UNF
F37	4-Hole, Square Mount, Aligned Manifold Ports, 1/2" Drilled
F39	4-Hole, Square Mount, Offset Ports, Valve Cavity, 7/8-14 UNF

4. SELECT A SHAFT OPTION

01	7/8" 13 Tooth Spline	12	25mm Straight
02	1" 6B Spline, 1/4-20 Tap	13	1" Tapered
05	1" - 9.5 [.375] Pinhole	15	1" Straight Extended
10	1" Straight	16	25mm Straight Extended

► The 15 & 16 extended shafts are designed for use with one of the speed sensor options listed in STEP 7.

5. SELECT A PAINT OPTION

A	Black
B	Black, Unpainted Mounting Surface
C	No Paint

6. SELECT A VALVE CAVITY / CARTRIDGE OPTION

A	None	E	104 bar [1500 psi] Relief
B	Valve Cavity Only	F	121 bar [1750 psi] Relief
C	69 bar [1000 psi] Relief	G	138 bar [2000 psi] Relief
D	86 bar [1250 psi] Relief		

► Valve cavity is only available on the A19 & F39 housings.

7. SELECT AN ADD-ON OPTION

A	Standard
B	Lock Nut
C	Solid Hex Nut
W	Speed Sensor, Dual, 4-Pin Male Weatherpack Connector
X	Speed Sensor, Dual, 4-Pin M12 Male Connector
Y	Speed Sensor, Single, 3-Pin Male Weatherpack Connector
Z	Speed Sensor, Single, 4-Pin M12 Male Connector

8. SELECT A MISCELLANEOUS OPTION

AA	None
AC	Freeturning Rotor