

SB Series

Hydraulic Brake



SB (930 Series)

Hydraulic Brake

OVERVIEW

The SB Series is a multiple-wet-disc-brake that provides superior performance in an extremely compact package. Unlike conventional brakes offered today, the SB brake is performance-matched to fit the full range of small-frame SAE A mount motors available today. With an overall diameter of less than 137mm [5.4 in] the SB has a holding capacity in excess of 620 Nm [5,500 lb-in] and is easily mated to a variety of global industry standard motor mounting and shaft options. In addition, the SB Series can be used as a stand-alone brake solution without an input drive motor. This option further opens design flexibility to meet a wider variety of application needs.

TYPICAL APPLICATIONS

Wheel drives, positioners, conveyors, door openers, swing drives, and more

SERIES DESCRIPTIONS

930 - Hydraulic Brake
Standard

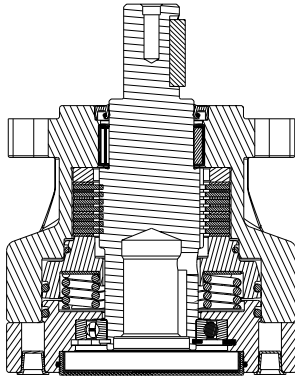

FEATURES / BENEFITS

- All wear components are fully immersed in fluid (wet multi-disc design).
- Performance-matched to fit small-frame motors with SAE A mounts.
- Release pressure independent of motor pressure
- Brake directly coupled to the output shaft
- Wide-variety of input and output shaft options
- Environmentally sealed / factory prefilled with oil
- Proven, Quiet, Trouble-Free Operation
- Compact, Cost-Effective Package
- Simplifies System Circuits - Eliminates Need for Pressure-Reducing Valve
- Series Operating Capability
- Reliable Performance - Fewer Critical Components
- Design Flexibility
- Global Interchangeability
- Suited for "Stand Alone" Brake Applications
- Ease of Installation

SPECIFICATIONS

Code	225	315	415	520	620
Holding Torque	225 Nm [2,000 lb-in]	315 Nm [2,800 lb-in]	415 Nm [3,700 lb-in]	520 Nm [4,600 lb-in]	620 Nm [5,500 lb-in]
Max. Release Pressure	250 bar [3,625 psi]				
Full Release Pressure	20 bar [290 psi]	20 bar [290 psi]	20 bar [290 psi]	31 bar [450 psi]	31 bar [450 psi]
Release Volume	8.3 cm ³ [.51 in ³]				
Unit Weight	8 kg [17.6 lb]				

SB Series

Hydraulic Brake



SB (930 Series) Hydraulic Brake

HOUSINGS

► Dimensions shown are without paint. Paint thickness can be up to 0.13 [.005].

2-HOLE, SAE A BRAKE MOUNT

A10 7/16-20 UNF **A11** G 1/4

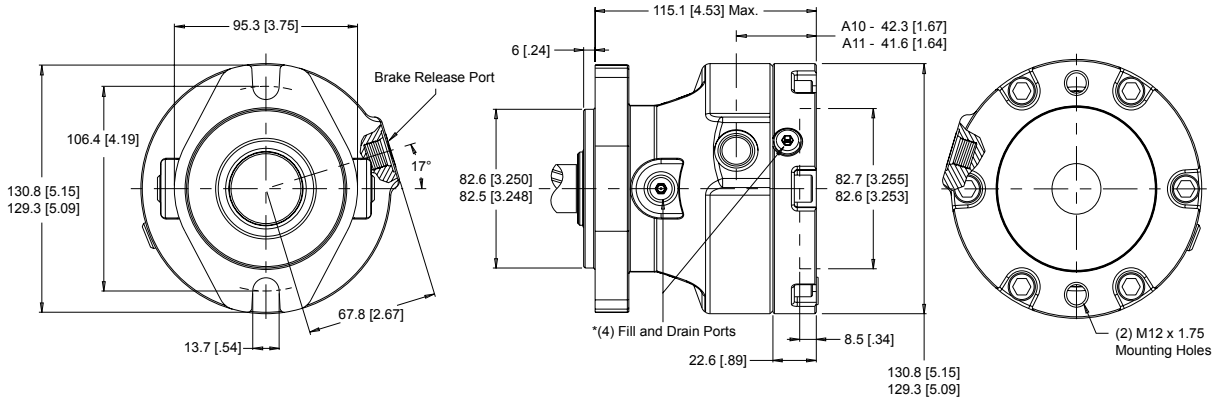

4-HOLE, SAE A BRAKE MOUNT

A30 7/16-20 UNF **A31** G 1/4

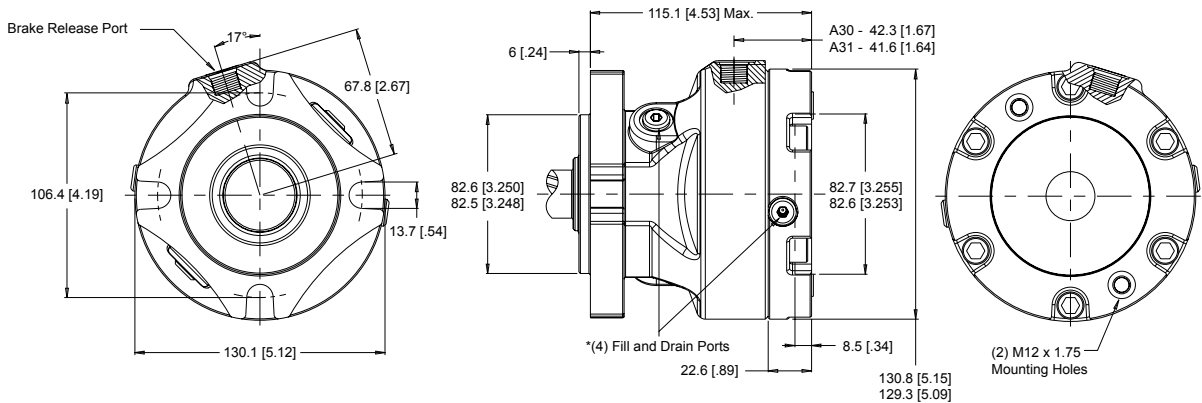

► Cast Dimensions are ± 0.8 mm [.030 in.] *Fill and drain ports for filling and draining the brake only. No system connections are to be made to the fill and drain ports. These ports are not suitable for use in a cooling loop.

SB (930 Series) Hydraulic Brake

SHAFTS

ZW 1" Straight, 6B Input

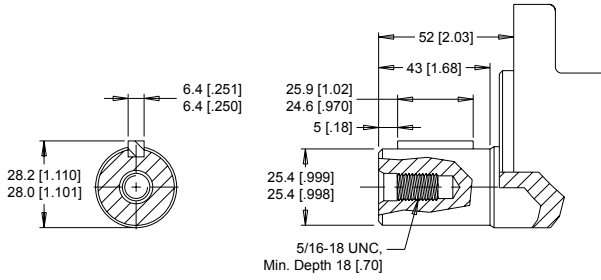

ZY 25mm Straight, 25mm Input **ZT** 25mm Straight, 6B Input

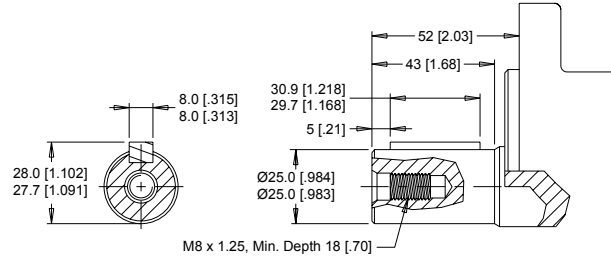

ZX 32mm Straight, 25mm Input **ZU** 32mm Straight, 6B Input

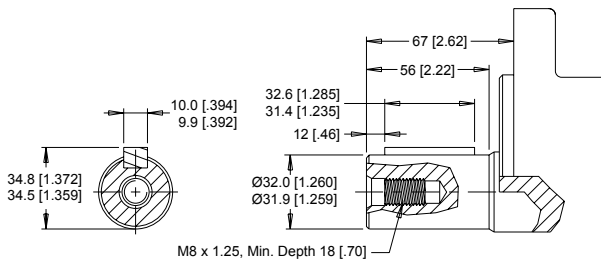

ZZ 6B Spline, 6B Input

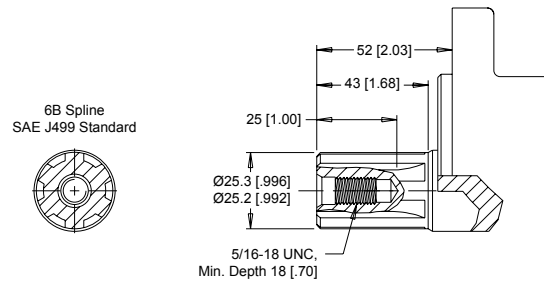

6B INPUT DIMENSIONS

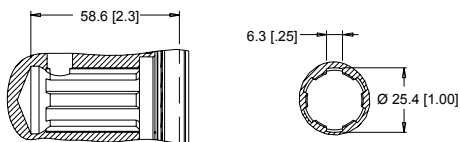

25MM INPUT DIMENSIONS

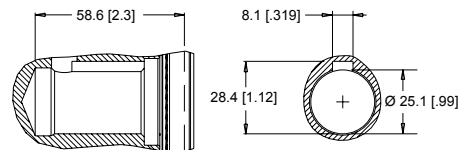

SB (930 Series)

Hydraulic Brake

INSTALLATION INFORMATION

The SB Brake is a wet multi-disc type static brake and is shipped factory filled with fluid. The fluid used is a standard SAE 20 hydraulic fluid. A hydraulic motor can be mounted to the SB Brake to provide a complete motor/brake package. A shipping cover protects and seals the input interface until it is ready for installation. The shipping cover is removed by removing the two cap screws and following the motor installation procedure below. Mounting pilot surfaces need to be free of paint or other substances for proper assembly and leak-free performance. Standard SB brakes are sold unpainted with an easy to remove shipping cover. Stand-alone SB brakes come standard painted and factory installed cover.

The input interface must be sealed to keep the brake environmentally protected and bearings fully immersed in fluid for proper lubrication and long life. Standard SAE 20 hydraulic oil is used in the brake cavity as well as typically used in hydraulic systems.

An internal seal is provided to seal long-pilot motors. When a short-pilot motor is used, an o-ring face seal is needed to properly seal the motor/brake interface. Two mounting bolts (M12 x 1.75 thread) and an o-ring seal with mounting instructions are included in the brake installation kit 930999001 and shipped with each SB Brake.

913 SERIES BRAKE INSTALLATION

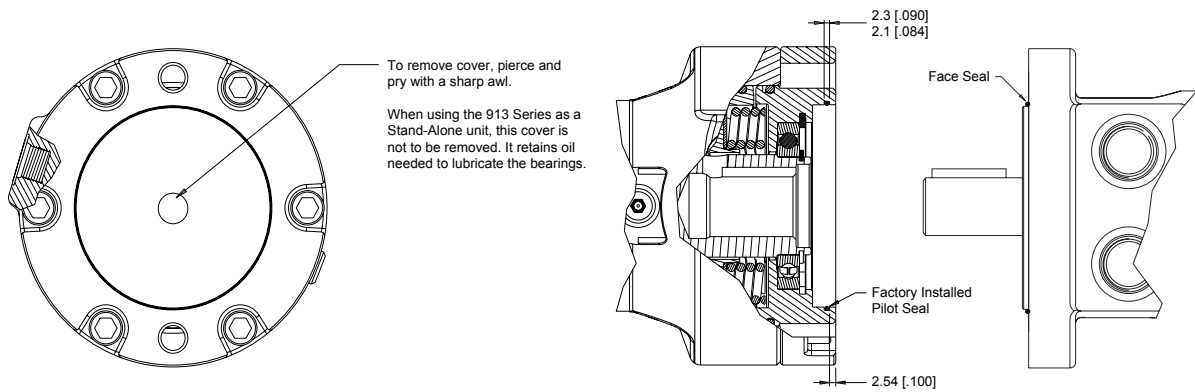

► The factory installed pilot seal may be left in place. However, this seal will not provide proper sealing for motors with short pilot mounts, therefore, the face seal contained in the mounting kit must be used.

TECHNICAL INFORMATION

ALLOWABLE SHAFT LOAD / BEARING CURVE

The bearing curve represents allowable bearing loads based on ISO 281 bearing capacity for an L_{10} life of 2,000 hours at 100 rpm. Radial loads for speeds other than 100 rpm may be calculated using the multiplication factor table on page 10.

BRAKE MOUNTS

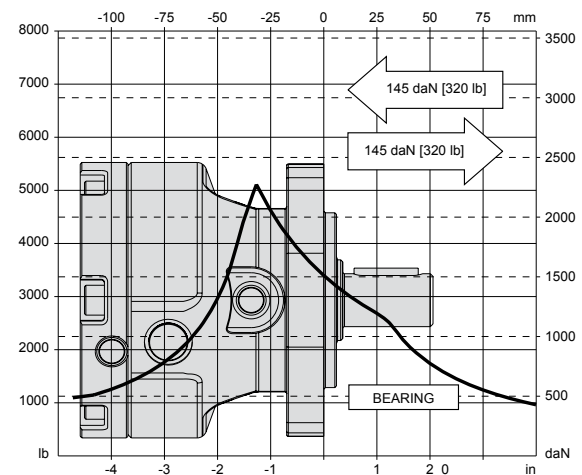

SB Series

Hydraulic Brake



SB (930 Series)

Hydraulic Brake

ORDERING INFORMATION

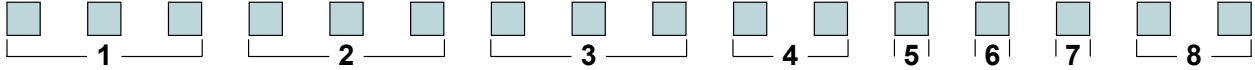

1. CHOOSE SERIES DESIGNATION

930 Hydraulic Brake

2. SELECT A HOLDING TORQUE

225 225 Nm [2000 lb-in]

520 520 Nm [4600 lb-in]

315 315 Nm [2800 lb-in]

620 620 Nm [5500 lb-in]

415 415 Nm [3700 lb-in]

3. SELECT A MOUNT & PORT OPTION

A10 2-Hole, SAE A Brake Mount, 7/16-20 UNF

A11 2-Hole, SAE A Brake Mount, G 1/4

A30 4-Hole, SAE A Brake Mount, 7/16-20 UNF

A31 4-Hole, SAE A Brake Mount, G 1/4

4. SELECT A SHAFT OPTION

ZT 25mm Straight, 6B Input

ZX 32mm Straight, 25mm Input

ZU 32mm Straight, 6B Input

ZY 25mm Straight, 25mm Input

ZW 1" Straight, 6B Input

6B Spline, 6B Input

5. SELECT A PAINT OPTION

A Black

B Black, Unpainted Mounting Surface

Z No Paint

6. SELECT A VALVE CAVITY / CARTRIDGE OPTION

A None

7. SELECT AN ADD-ON OPTION

A Standard

8. SELECT A MISCELLANEOUS OPTION

AA Standard