

WP (All Series)

For Light Duty Applications

OVERVIEW

The WP motor series is an economical alternative to more complex geroler designs that still provides high efficiency across a wide performance range. These motors are intended for light-duty applications requiring high torque in a compact package and are suitable for industrial and mobile applications including car wash brushes, food processing equipment, conveyors, machine tools, agricultural equipment, sweepers, skid steer attachments, and more.

FEATURES / BENEFITS

- Built-in check valves offer versatility and increased seal life.
- A variety of mounts and shafts provide flexibility in application design.
- Spool valve design gives superior performance and smooth operation over a wide speed and torque range.
- Standard high pressure shaft seals offer superior seal life and performance.

TYPICAL APPLICATIONS

agriculture equipment, conveyors, carwashes, sweepers, food processing, grain augers, spreaders, feed rollers, augers, brush drives and more

SERIES DESCRIPTIONS

155/156 - Hydraulic Motor
Standard

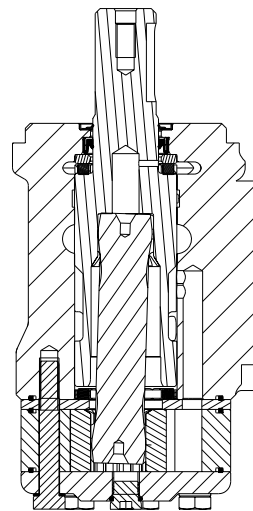

SPECIFICATIONS

CODE	Displacement cm ³ [in ³ /rev]	Max. Speed rpm		Max. Flow lpm [gpm]		Max. Torque Nm [lb-in]		Max. Pressure bar [psi]		
		cont.	inter.	cont.	inter.	cont.	inter.	cont.	inter.	peak
025	25 [1.5]	1570	1687	40 [11]	45 [12]	35 [310]	48 [425]	100 [1450]	140 [2030]	225 [3260]
032	32 [2.0]	1550	1674	50 [13]	55 [15]	45 [398]	57 [504]	100 [1450]	140 [2030]	225 [3260]
040	40 [2.5]	1471	1670	60 [16]	70 [19]	65 [575]	74 [655]	100 [1450]	140 [2030]	225 [3260]
050	50 [3.0]	1208	1500	60 [16]	75 [20]	91 [805]	108 [956]	140 [2030]	175 [2540]	240 [3480]
060	59 [3.6]	1185	1271	60 [16]	75 [20]	125 [1106]	136 [1204]	160 [2320]	175 [2540]	240 [3480]
080	78 [4.8]	896	960	60 [16]	75 [20]	164 [1451]	183 [1620]	160 [2320]	175 [2540]	240 [3480]
100	96 [5.9]	728	780	60 [16]	75 [20]	195 [1726]	213 [1885]	160 [2320]	175 [2540]	240 [3480]
125	125 [7.6]	559	599	60 [16]	75 [20]	258 [2285]	278 [2460]	160 [2320]	175 [2540]	240 [3480]
160	154 [9.4]	452	483	60 [16]	75 [20]	321 [2840]	362 [3205]	160 [2320]	175 [2540]	240 [3480]
200	190 [11.6]	367	385	60 [16]	75 [20]	380 [3365]	420 [3720]	150 [2180]	175 [2540]	240 [3480]
250	240 [14.6]	291	312	60 [16]	75 [20]	445 [3940]	557 [4930]	140 [2030]	175 [2540]	240 [3480]
315	303 [18.5]	228	245	60 [16]	75 [20]	460 [4071]	602 [5330]	120 [1740]	160 [2320]	200 [2900]
400	388 [23.7]	155	189	60 [16]	75 [20]	488 [4320]	625 [5532]	95 [1380]	125 [1810]	180 [2610]

► Performance data is typical. Performance of production units varies slightly from one motor to another. See page 9 for additional information on product testing. Running at intermittent ratings should not exceed 10% of every minute of operation.

WP (All Series) For Light Duty Applications

DISPLACEMENT PERFORMANCE

		Pressure - bar [psi]			Max. Cont.		Max. Inter.	
025		30 [435]	60 [870]	80 [1160]	100 [1450]	120 [1740]	140 [2030]	
		25 cm ³ [1.5 in ³] / rev						
		Torque - Nm [lb-in], Speed rpm				Intermittent Ratings - 10% of Operation		
Flow - lpm [gpm]	5 [1.3]	9 [80] 186	18 [159] 160	25 [221] 134	32 [283] 101	35 [310] 106		200
	10 [2.6]	10 [88] 386	18 [159] 352	26 [230] 323	34 [301] 280	37 [327] 255	48 [425] 210	400
	15 [4.0]	9 [80] 568	19 [168] 537	26 [230] 505	35 [310] 467	38 [336] 431	44 [389] 390	600
	20 [5.3]	8 [71] 777	19 [168] 736	25 [221] 692	33 [292] 660	39 [345] 608	45 [398] 566	800
	25 [6.6]	7 [62] 972	18 [159] 920	26 [230] 870	32 [283] 840	39 [345] 803	45 [398] 756	1000
	30 [7.9]	6 [53] 1167	17 [150] 1122	25 [221] 1088	32 [283] 1055	39 [345] 998	44 [389] 976	1200
	35 [9.2]	5 [44] 1360	16 [142] 1318	24 [212] 1282	31 [274] 1258	37 [327] 1216	43 [381] 1160	1400
	40 [10.6]	5 [44] 1570	15 [133] 1503	22 [195] 1476	31 [274] 1432	36 [319] 1394	41 [363] 1359	1600
	45 [11.9]		13 [115] 1687	20 [177] 1636	28 [248] 1600	34 [301] 1558	39 [345] 1516	1800
	Max. Max. Inter. Cont.							
Rotor Width		Overall Efficiency - 70 - 100% <input type="checkbox"/> 40 - 69% <input type="checkbox"/> 0 - 39% <input checked="" type="checkbox"/>						
4.1 [160] mm [in]		Theoretical Torque - Nm [lb-in]						
		12 [106]	24 [211]	32 [282]	40 [352]	48 [423]	56 [493]	
		Displacement tested at 45°C [113°F] with an oil viscosity of 46cSt [213 SUS]						

		Pressure - bar [psi]			Max. Cont.		Max. Inter.	
032		30 [435]	60 [870]	80 [1160]	100 [1450]	120 [1740]	140 [2030]	
		32 cm ³ [2.0 in ³] / rev						
		Torque - Nm [lb-in], Speed rpm				Intermittent Ratings - 10% of Operation		
Flow - lpm [gpm]	5 [1.3]	11 [97] 149	24 [212] 135	35 [310] 114	37 [327] 94			156
	10 [2.6]	12 [106] 308	27 [239] 284	37 [327] 270	43 [381] 250	46 [407] 240	56 [496] 211	313
	15 [4.0]	11 [97] 465	26 [230] 444	36 [319] 429	45 [398] 398	48 [425] 378	57 [504] 355	469
	20 [5.3]	10 [88] 624	25 [221] 589	35 [310] 575	44 [389] 557	46 [407] 544	56 [496] 524	625
	25 [6.6]	9 [80] 780	24 [212] 771	34 [301] 751	42 [372] 735	45 [398] 719	54 [478] 695	781
	30 [7.9]	8 [71] 931	23 [204] 908	32 [283] 895	40 [354] 876	45 [398] 857	52 [460] 822	938
	35 [9.2]	7 [62] 1086	20 [177] 1066	29 [257] 1051	39 [345] 1030	43 [381] 1012	51 [451] 981	1094
	40 [10.6]	7 [62] 1240	19 [168] 1212	27 [239] 1190	38 [336] 1178	43 [381] 1145	50 [442] 1121	1250
	45 [11.9]	6 [53] 1400	18 [159] 1382	26 [230] 1366	35 [310] 1340	42 [372] 1314	48 [425] 1280	1406
	50 [13.2]	5 [44] 1550	16 [142] 1526	24 [212] 1500	31 [274] 1478	40 [354] 1452	46 [407] 1418	1563
55 [14.5]		12 [106] 1674	20 [177] 1641	28 [248] 1617	34 [301] 1584	39 [345] 1555	1719	
Max. Max. Inter. Cont.								
Rotor Width		Overall Efficiency - 70 - 100% <input type="checkbox"/> 40 - 69% <input type="checkbox"/> 0 - 39% <input checked="" type="checkbox"/>						
5.1 [200] mm [in]		Theoretical Torque - Nm [lb-in]						
		15 [135]	31 [271]	41 [361]	51 [451]	61 [541]	71 [631]	
		Displacement tested at 45°C [113°F] with an oil viscosity of 46cSt [213 SUS]						

► Performance data is typical. Performance of production units varies slightly from one motor to another. See page 10.03 for additional information on product testing.

WP (All Series)

For Light Duty Applications

DISPLACEMENT PERFORMANCE

		Pressure - bar [psi]						Max. Cont.	Max. Inter.
040		30 [435]	60 [870]	80 [1160]	100 [1450]	120 [1740]	140 [2030]		
40 cm ³ [2.5 in ³] / rev								Intermittent Ratings - 10% of Operation	
		Torque - Nm [lb-in], Speed rpm							
Flow - lpm [gpm]	5 [1.3]	15 [133] 113	31 [274] 98	38 [336] 83	48 [425] 60	56 [496] 48			125
	10 [2.6]	14 [124] 238	31 [274] 222	41 [363] 204	54 [478] 182	62 [549] 161	70 [619] 114		250
	20 [5.3]	13 [115] 482	32 [283] 458	41 [363] 442	53 [469] 423	65 [575] 402	74 [655] 381		500
	30 [7.9]	12 [106] 730	30 [265] 704	39 [345] 687	51 [451] 668	63 [558] 646	74 [655] 624		750
	40 [10.6]	10 [88] 968	27 [239] 949	39 [345] 928	51 [451] 908	61 [540] 892	72 [637] 870		1000
	50 [13.2]	7 [62] 1219	25 [221] 1191	37 [327] 1173	49 [434] 1150	59 [522] 1127	71 [628] 1107		1250
	60 [15.8]	4 [35] 1471	23 [204] 1428	34 [301] 1411	46 [407] 1387	56 [496] 1369	68 [602] 1341		1500
	70 [18.5]		16 [142] 1670	30 [265] 1653	41 [363] 1627	52 [460] 1612	64 [566] 1598		2000
Rotor Width		Overall Efficiency - 70 - 100% <input type="checkbox"/> 40 - 69% <input type="checkbox"/> 0 - 39% <input type="checkbox"/>							
6.6 [260] mm [in]		Theoretical Torque - Nm [lb-in]							
		19 [168]	38 [336]	50 [442]	64 [566]	76 [673]	89 [788]		
		Displacement tested at 45°C [113°F] with an oil viscosity of 46cSt [213 SUS]							

		Pressure - bar [psi]						Max. Cont.	Max. Inter.
050		30 [435]	60 [870]	80 [1160]	100 [1450]	120 [1740]	140 [2030]	160 [2320]	175 [2540]
50 cm ³ [3.0 in ³] / rev								Intermittent Ratings - 10% of Operation	
		Torque - Nm [lb-in], Speed rpm							
Flow - lpm [gpm]	5 [1.3]	19 [168] 100	39 [345] 85	48 [425] 75	62 [549] 64	75 [664] 48			101
	10 [2.6]	20 [177] 197	38 [336] 196	50 [442] 174	63 [558] 159	78 [690] 146	92 [814] 127	102 [903] 101	107 [947] 97
	20 [5.3]	18 [159] 400	38 [336] 386	52 [460] 371	64 [566] 355	78 [690] 341	90 [796] 314	104 [920] 292	108 [956] 290
	30 [7.9]	15 [133] 600	37 [327] 585	50 [442] 571	64 [566] 560	77 [681] 540	89 [788] 516	103 [912] 499	107 [947] 495
	40 [10.6]	12 [106] 808	31 [274] 800	45 [398] 790	59 [522] 770	73 [646] 766	87 [770] 733	99 [876] 703	106 [938] 697
	50 [13.2]	9 [80] 1009	27 [239] 1006	41 [363] 986	55 [487] 982	68 [602] 964	84 [743] 956	98 [867] 930	105 [929] 872
	60 [15.8]	6 [53] 1208	24 [212] 1200	37 [327] 1196	53 [469] 1188	64 [566] 1176	82 [726] 1160	95 [841] 1140	102 [903] 963
	75 [18.5]	3 [27] 1410	17 [150] 1396	32 [283] 1382	44 [389] 1370	58 [513] 1358	80 [708] 1347	93 [823] 1334	98 [867] 1315
Max. Inter.	75 [19.8]	15 [133] 1500	30 [265] 1488	40 [354] 1473	56 [496] 1457	77 [681] 1439	88 [779] 1412	93 [823] 1388	1515
Rotor Width		Overall Efficiency - 70 - 100% <input type="checkbox"/> 40 - 69% <input type="checkbox"/> 0 - 39% <input type="checkbox"/>							
6.6 [260] mm [in]		Theoretical Torque - Nm [lb-in]							
		24 [212]	47 [416]	63 [558]	79 [699]	95 [841]	110 [973]	126 [1115]	138 [1221]
		Displacement tested at 45°C [113°F] with an oil viscosity of 46cSt [213 SUS]							

► Performance data is typical. Performance of production units varies slightly from one motor to another. See page 10.03 for additional information on product testing.

WP (All Series) For Light Duty Applications

DISPLACEMENT PERFORMANCE

		Pressure - bar [psi]							Max. Cont.	Max. Inter.
060		30 [435]	60 [870]	80 [1160]	100 [1450]	120 [1740]	140 [2030]	160 [2320]	175 [2540]	
59 cm ³ [3.6 in ³] / rev		Intermittent Ratings - 10% of Operation								
Torque - Nm [lb-in], Speed rpm										
Flow - lpm [gpm]	5 [1.3]	20 [177] 83	46 [407] 79	65 [575] 72	80 [708] 64	95 [841] 51	112 [991] 38			85
	10 [2.6]	22 [195] 169	47 [416] 164	66 [584] 155	81 [717] 142	96 [850] 135	113 [1000] 124	125 [1106] 108	136 [1204] 88	170
	20 [5.3]	20 [177] 338	45 [398] 332	64 [566] 320	80 [708] 309	93 [823] 290	111 [982] 276	123 [1088] 245	134 [1186] 222	339
	30 [7.9]	17 [150] 507	43 [381] 502	62 [549] 493	76 [673] 482	89 [788] 468	109 [965] 454	121 [1071] 424	131 [1159] 400	509
	40 [10.6]	14 [124] 678	41 [363] 669	58 [513] 660	73 [646] 645	87 [770] 630	105 [929] 616	117 [1035] 594	127 [1124] 582	678
	50 [13.2]	10 [88] 845	37 [327] 841	55 [487] 833	70 [619] 818	84 [743] 805	102 [903] 792	113 [1000] 770	122 [1080] 754	848
	60 [15.8]	7 [62] 1014	34 [301] 1005	52 [460] 999	66 [584] 992	82 [726] 982	99 [876] 968	109 [965] 956	118 [1044] 933	1017
	70 [18.5]	4 [35] 1185	27 [239] 1182	47 [416] 1180	62 [549] 1175	76 [673] 1158	93 [823] 1144	104 [920] 1128	114 [1009] 1112	1186
Max. Inter.	75 [19.8]	22 [195] 1271	43 [381] 1265	58 [513] 1256	73 [646] 1241	86 [761] 1228	100 [885] 1212	110 [973] 1196	1271	
Rotor Width										
8.0 [3.14] mm [in]										
Overall Efficiency - 70 - 100% <input type="checkbox"/> 40 - 69% <input type="checkbox"/> 0 - 39% <input checked="" type="checkbox"/>										
Theoretical Torque - Nm [lb-in]										
28 [249]		56 [499]	75 [665]	94 [831]	113 [998]	132 [1164]	150 [1330]	164 [1455]		
Displacement tested at 45°C [113°F] with an oil viscosity of 46cSt [213 SUS]										

		Pressure - bar [psi]							Max. Cont.	Max. Inter.
080		30 [435]	60 [870]	80 [1160]	100 [1450]	120 [1740]	140 [2030]	160 [2320]	175 [2540]	
78 cm ³ [4.8 in ³] / rev		Intermittent Ratings - 10% of Operation								
Torque - Nm [lb-in], Speed rpm										
Flow - lpm [gpm]	5 [1.3]	32 [283] 60	62 [549] 56	80 [708] 50	106 [938] 42	125 [1106] 30				64
	10 [2.6]	31 [274] 125	64 [566] 118	84 [743] 112	104 [920] 104	120 [1062] 98	142 [1257] 82	162 [1434] 67	175 [1549] 50	128
	20 [5.3]	26 [230] 254	60 [531] 245	84 [743] 236	102 [903] 228	125 [1106] 215	144 [1274] 204	164 [1451] 190	183 [1619] 175	256
	30 [7.9]	24 [212] 384	56 [496] 374	81 [717] 366	100 [885] 358	122 [1080] 346	142 [1257] 335	160 [1416] 318	175 [1549] 305	385
	40 [10.6]	19 [168] 512	53 [469] 505	75 [664] 494	96 [850] 483	118 [1044] 473	140 [1239] 462	158 [1398] 450	170 [1504] 438	513
	50 [13.2]	14 [124] 638	46 [407] 630	70 [619] 625	92 [814] 615	110 [973] 606	135 [1195] 593	156 [1381] 580	168 [1487] 568	641
	60 [15.8]	10 [88] 768	42 [372] 762	66 [584] 756	86 [761] 748	106 [938] 738	128 [1133] 728	150 [1327] 717	164 [1451] 694	769
	70 [18.5]	6 [53] 896	36 [319] 890	56 [496] 882	78 [690] 872	98 [867] 860	118 [1044] 846	140 [1239] 830	160 [1416] 816	897
Max. Inter.	75 [19.8]	3 [27] 960	27 [239] 955	50 [442] 948	74 [655] 938	92 [814] 926	113 [1000] 916	133 [1177] 896	148 [1310] 802	962
Rotor Width										
10.4 [4.10] mm [in]										
Overall Efficiency - 70 - 100% <input type="checkbox"/> 40 - 69% <input type="checkbox"/> 0 - 39% <input checked="" type="checkbox"/>										
Theoretical Torque - Nm [lb-in]										
37 [327]		75 [664]	100 [885]	125 [1106]	149 [1319]	174 [1540]	199 [1761]	218 [1929]		
Displacement tested at 45°C [113°F] with an oil viscosity of 46cSt [213 SUS]										

► Performance data is typical. Performance of production units varies slightly from one motor to another. See page 10.03 for additional information on product testing.

WP (All Series) For Light Duty Applications

DISPLACEMENT PERFORMANCE

		Pressure - bar [psi]						Max. Cont.	Max. Inter.
100		30 [435]	60 [870]	80 [1160]	100 [1450]	120 [1740]	140 [2030]	160 [2320]	175 [2540]
		96 cm ³ [5.9 in ³] / rev						Intermittent Ratings - 10% of Operation	
		Torque - Nm [lb-in], Speed rpm							
Flow - lpm [gpm]	5 [1.3]	43 [381] 51	82 [726] 42	109 [965] 35	131 [1159] 25				52
	10 [2.6]	43 [381] 99	84 [743] 93	108 [956] 84	133 [1177] 72	152 [1345] 62	180 [1593] 48	197 [1743] 24	104
	20 [5.3]	41 [363] 205	79 [699] 202	107 [947] 197	127 [1124] 192	154 [1363] 182	178 [1575] 172	200 [1770] 140	208
	30 [7.9]	39 [345] 311	74 [655] 307	101 [894] 301	126 [1115] 294	152 [1345] 283	176 [1558] 271	198 [1752] 258	313
	40 [10.6]	29 [257] 413	63 [558] 410	93 [823] 406	121 [1071] 399	150 [1327] 388	172 [1522] 379	195 [1726] 368	417
	50 [13.2]	20 [177] 519	52 [460] 515	85 [752] 510	115 [1018] 503	148 [1310] 492	169 [1496] 480	193 [1708] 464	203 [1796] 446
	60 [15.8]	17 [150] 624	53 [469] 620	83 [735] 615	111 [982] 608	138 [1221] 600	165 [1460] 582	183 [1619] 565	193 [1708] 548
	70 [18.5]	11 [97] 728	42 [372] 726	73 [646] 723	93 [823] 714	126 [1115] 706	159 [1407] 684	172 [1522] 668	183 [1619] 646
Max. Inter.	75 [19.8]	6 [53] 780	35 [310] 771	61 [540] 764	89 [788] 755	118 [1044] 736	145 [1283] 724	156 [1381] 712	176 [1558] 699
		Overall Efficiency - 70 - 100% <input type="checkbox"/> 40 - 69% <input type="checkbox"/> 0 - 39% <input type="checkbox"/>							
		Theoretical Torque - Nm [lb-in]							
Rotor Width									
13.0 [510] mm [in]		46 [407]	92 [814]	122 [1080]	153 [1354]	183 [1623]	214 [1894]	245 [2168]	268 [2372]
		Displacement tested at 45°C [113°F] with an oil viscosity of 46cSt [213 SUS]							

		Pressure - bar [psi]						Max. Cont.	Max. Inter.
125		30 [435]	60 [870]	80 [1160]	100 [1450]	120 [1740]	140 [2030]	160 [2320]	175 [2540]
		125 cm ³ [7.6 in ³] / rev						Intermittent Ratings - 10% of Operation	
		Torque - Nm [lb-in], Speed rpm							
Flow - lpm [gpm]	5 [1.3]	52 [460] 38	95 [841] 35	135 [1195] 32	168 [1487] 27				40
	10 [2.6]	50 [442] 78	98 [867] 74	138 [1221] 69	172 [1522] 62	190 [1681] 54	234 [2071] 45	258 [2283] 35	80
	20 [5.3]	50 [442] 158	96 [850] 152	132 [1168] 144	168 [1487] 135	202 [1788] 124	236 [2088] 110	256 [2265] 94	160
	30 [7.9]	44 [389] 238	92 [814] 232	126 [1115] 225	164 [1451] 215	198 [1752] 210	232 [2053] 198	262 [2319] 168	240
	40 [10.6]	35 [310] 319	82 [726] 316	118 [1044] 312	160 [1416] 308	193 [1708] 300	226 [2000] 288	252 [2230] 262	320
	50 [13.2]	31 [274] 399	77 [681] 396	108 [956] 392	155 [1372] 383	182 [1611] 368	220 [1947] 354	238 [2106] 338	262 [2319] 326
	60 [15.8]	15 [133] 479	64 [566] 478	97 [858] 475	146 [1292] 470	166 [1469] 463	210 [1858] 454	224 [1982] 443	256 [2265] 434
	70 [18.5]	8 [71] 559	50 [442] 555	90 [796] 548	140 [1239] 538	162 [1434] 524	204 [1805] 516	209 [1850] 500	236 [2088] 488
Max. Inter.	75 [19.8]	40 [354] 599	71 [628] 594	128 [1133] 588	158 [1398] 576	192 [1699] 565	199 [1761] 536	224 [1982] 524	
		Overall Efficiency - 70 - 100% <input type="checkbox"/> 40 - 69% <input type="checkbox"/> 0 - 39% <input type="checkbox"/>							
		Theoretical Torque - Nm [lb-in]							
Rotor Width									
16.8 [660] mm [in]		60 [531]	119 [1053]	159 [1407]	199 [1761]	239 [2115]	279 [2469]	318 [2814]	348 [3080]
		Displacement tested at 45°C [113°F] with an oil viscosity of 46cSt [213 SUS]							

► Performance data is typical. Performance of production units varies slightly from one motor to another. See page 10.03 for additional information on product testing.

WP (All Series) For Light Duty Applications

DISPLACEMENT PERFORMANCE

		Pressure - bar [psi]						Max. Cont.	Max. Inter.
160		30 [435]	60 [870]	80 [1160]	100 [1450]	120 [1740]	140 [2030]	160 [2320]	175 [2540]
		160 cm ³ [9.4 in ³] / rev							
		Torque - Nm [lb-in], Speed rpm						Intermittent Ratings - 10% of Operation	
Flow - lpm [gpm]	5 [1.3]	56 [496] 30	112 [991] 25	154 [1363] 18	201 [1779] 10				32
	10 [2.6]	58 [513] 63	115 [1018] 60	156 [1381] 56	205 [1814] 52	245 [2168] 48	285 [2522] 37		65
	20 [5.3]	60 [532] 128	123 [1089] 125	162 [1434] 121	202 [1788] 116	242 [2142] 110	282 [2496] 100	327 [2894] 86	130
	30 [7.9]	50 [443] 193	117 [1035] 190	157 [1389] 187	197 [1743] 183	238 [2106] 179	278 [2460] 173	322 [2850] 160	194
	40 [10.6]	48 [425] 257	113 [1000] 255	155 [1372] 252	195 [1726] 248	236 [2089] 244	273 [2416] 239	318 [2814] 224	258
	50 [13.2]	32 [283] 323	106 [938] 320	149 [1319] 316	188 [1664] 312	235 [2080] 306	267 [2363] 299	313 [2770] 288	323
	60 [15.8]	23 [204] 387	88 [779] 384	133 [1177] 380	178 [1575] 375	212 [1876] 371	260 [2301] 366	308 [2726] 358	387
	70 [18.5]	16 [142] 452	82 [726] 451	128 [1133] 448	170 [1505] 444	206 [1823] 436	255 [2257] 430	302 [2673] 423	453
	75 [19.8]	10 [89] 483	79 [699] 481	124 [1097] 477	164 [1451] 472	201 [1779] 466	248 [2195] 460	296 [2620] 450	485
		Overall Efficiency - 70 - 100% <input type="checkbox"/> 40 - 69% <input type="checkbox"/> 0 - 39% <input type="checkbox"/>							
Rotor Width		Theoretical Torque - Nm [lb-in]							
20.8 [8.20] mm [in]		74 [651]	147 [1302]	196 [1736]	245 [2170]	282 [2496]	343 [3038]	392 [3472]	429 [3798]
Displacement tested at 45°C [113°F] with an oil viscosity of 46cSt [213 SUS]									

		Pressure - bar [psi]						Max. Cont.	Max. Inter.
200		30 [435]	60 [870]	80 [1160]	100 [1450]	115 [1670]	140 [2030]	150 [2180]	175 [2540]
		190 cm ³ [11.6 in ³] / rev							
		Torque - Nm [lb-in], Speed rpm						Intermittent Ratings - 10% of Operation	
Flow - lpm [gpm]	5 [1.3]	75 [664] 25	158 [1398] 22	200 [1770] 20	241 [2133] 10				26
	10 [2.6]	78 [690] 51	160 [1416] 49	204 [1805] 45	252 [2230] 39	291 [2575] 35	348 [3080] 29	377 [3336] 22	53
	20 [5.3]	74 [655] 104	156 [1381] 102	200 [1770] 99	246 [2177] 95	293 [2593] 89	354 [3133] 83	380 [3363] 76	105
	30 [7.9]	70 [619] 157	152 [1345] 155	196 [1735] 152	240 [2124] 148	290 [2566] 143	352 [3115] 137	378 [3345] 130	158
	40 [10.6]	65 [575] 210	147 [1301] 208	190 [1681] 205	228 [2018] 200	286 [2531] 193	340 [3009] 186	376 [3327] 178	211
	50 [13.2]	54 [478] 262	142 [1257] 260	180 [1593] 258	222 [1965] 254	277 [2451] 249	333 [2947] 243	356 [3150] 235	263
	60 [15.8]	36 [319] 315	128 [1133] 313	166 [1469] 309	210 [1858] 305	266 [2354] 299	322 [2850] 293	350 [3097] 284	316
	70 [18.5]	15 [133] 367	102 [903] 365	158 [1398] 362	202 [1788] 358	254 [2248] 352	302 [2673] 336	327 [2894] 330	368
	75 [19.8]		94 [832] 394	146 [1292] 390	194 [1717] 385	230 [2035] 380	290 [2566] 374	317 [2805] 365	395
		Overall Efficiency - 70 - 100% <input type="checkbox"/> 40 - 69% <input type="checkbox"/> 0 - 39% <input type="checkbox"/>							
Rotor Width		Theoretical Torque - Nm [lb-in]							
25.9 [1.020] mm [in]		91 [803]	182 [1611]	242 [2142]	303 [2677]	348 [3079]	424 [3748]	454 [4016]	529 [4685]
Displacement tested at 45°C [113°F] with an oil viscosity of 46cSt [213 SUS]									

► Performance data is typical. Performance of production units varies slightly from one motor to another. See page 10.03 for additional information on product testing.

WP (All Series) For Light Duty Applications

DISPLACEMENT PERFORMANCE

		Pressure - bar [psi]							Max. Cont.	Max. Inter.
250		30 [435]	60 [870]	85 [1230]	100 [1450]	125 [1810]	140 [2030]	160 [2320]	175 [2540]	
240 cm ³ [14.6 in ³] / rev		Intermittent Ratings - 10% of Operation								
		Torque - Nm [lb-in], Speed rpm								
Flow - lpm [gpm]	5 [1.3]	89 [788] 19	194 [1717] 16	264 [2336] 10	326 [2885] 6					21
	10 [2.6]	92 [814] 40	196 [1735] 36	268 [2372] 32	329 [2912] 21	394 [3487] 10				42
	20 [5.3]	90 [796] 81	192 [1699] 77	264 [2336] 72	321 [2841] 65	397 [3513] 50	445 [3938] 42	510 [4513] 36	554 [4903] 23	83
	30 [7.9]	86 [761] 124	185 [1637] 121	256 [2265] 115	314 [2779] 106	392 [3469] 94	439 [3855] 84	502 [4442] 76	557 [4929] 61	125
	40 [10.6]	82 [726] 165	179 [1584] 162	248 [2195] 158	305 [2699] 153	384 [3398] 144	431 [3814] 135	486 [4301] 125	545 [4823] 113	167
	50 [13.2]	69 [611] 207	169 [1496] 203	243 [2150] 195	293 [2593] 189	378 [3345] 183	421 [3726] 170	475 [4204] 157	526 [4655] 138	208
	60 [15.8]	48 [425] 250	152 [1345] 247	230 [2035] 243	282 [2496] 236	364 [3221] 222	407 [3602] 216	456 [4035] 205	508 [4496] 188	250
	70 [18.5]	37 [327] 291	139 [1230] 285	219 [1938] 278	263 [2327] 271	343 [3035] 256	386 [3416] 249	441 [3903] 234	496 [4389] 221	292
Max. Inter.	75 [19.8]	26 [230] 312	128 [1133] 310	205 [1814] 307	245 [2168] 302	328 [2903] 294	374 [3310] 270	428 [3788] 254	481 [4257] 242	313
Rotor Width		Overall Efficiency - 70 - 100% <input type="checkbox"/> 40 - 69% <input type="checkbox"/> 0 - 39% <input type="checkbox"/>								
32.5 [1.280] mm [in]		Theoretical Torque - Nm [lb-in]								
		115 [1018]	229 [2027]	325 [2875]	382 [3381]	478 [4230]	535 [4735]	611 [5407]	669 [5920]	
		Displacement tested at 45°C [113°F] with an oil viscosity of 46cSt [213 SUS]								

		Pressure - bar [psi]							Max. Cont.	Max. Inter.
315		30 [435]	50 [725]	70 [1015]	85 [1230]	100 [1450]	120 [1740]	140 [2030]	160 [2320]	
303 cm ³ [18.5 in ³] / rev		Intermittent Ratings - 10% of Operation								
		Torque - Nm [lb-in], Speed rpm								
Flow - lpm [gpm]	5 [1.3]	123 [1089] 16	200 [1770] 13	282 [2496] 10	344 [3044] 6					17
	10 [2.6]	117 [1035] 31	194 [1717] 29	277 [2451] 25	342 [3027] 21	399 [3531] 17				33
	20 [5.3]	112 [991] 64	196 [1735] 62	275 [2434] 58	340 [3009] 54	397 [3513] 49	460 [4071] 43	526 [4655] 32	605 [5354] 23	66
	30 [7.9]	104 [920] 98	183 [1620] 94	267 [2363] 90	322 [2850] 85	390 [3452] 79	448 [3965] 70	520 [4602] 62	602 [5328] 56	99
	40 [10.6]	86 [761] 129	168 [1487] 126	252 [2230] 122	304 [2690] 118	365 [3230] 113	440 [3894] 106	515 [4558] 99	588 [5204] 76	132
	50 [13.2]	73 [646] 164	156 [1381] 160	238 [2106] 155	288 [2549] 150	350 [3098] 144	424 [3752] 136	500 [4425] 127	571 [5053] 119	165
	60 [15.8]	60 [531] 195	140 [1239] 192	223 [1974] 188	270 [2390] 183	325 [2876] 176	396 [3505] 170	480 [4248] 164	546 [4832] 157	198
	70 [18.5]	37 [327] 228	122 [1080] 226	186 [1646] 223	254 [2248] 218	309 [2735] 212	368 [3257] 206	455 [4027] 196	527 [4664] 188	231
Max. Inter.	75 [19.8]	23 [204] 245	100 [885] 242	174 [1540] 238	237 [2097] 233	293 [2593] 228	359 [3177] 222	444 [3929] 215	516 [4567] 206	248
Rotor Width		Overall Efficiency - 60 - 100% <input type="checkbox"/> 40 - 59% <input type="checkbox"/> 0 - 39% <input type="checkbox"/>								
40.9 [1.610] mm [in]		Theoretical Torque - Nm [lb-in]								
		145 [1283]	241 [2133]	338 [2991]	410 [3628]	482 [4265]	579 [5124]	675 [5973]	772 [6832]	
		Displacement tested at 45°C [113°F] with an oil viscosity of 46cSt [213 SUS]								

► Performance data is typical. Performance of production units varies slightly from one motor to another. See page 10.03 for additional information on product testing.

WP Series

Light Duty Hydraulic Motor



WP (All Series) For Light Duty Applications

DISPLACEMENT PERFORMANCE

		Pressure - bar [psi]					Max. Cont.	Max. Inter.				
400		30 [435]	45 [650]	55 [800]	65 [940]	80 [1160]	95 [1380]	110 [1595]	125 [1810]			
388 cm ³ [23.7 in ³] / rev										Intermittent Ratings - 10% of Operation		
		Torque - Nm [lb-in], Speed rpm										
Flow - lpm [gpm]	5 [1.3]	144 [1274] 11	220 [1947] 10	270 [2389] 7	338 [2991] 5						13	Theoretical rpm
	10 [2.6]	146 [1292] 25	223 [1973] 23	272 [2407] 20	340 [3009] 16	412 [3646] 10	488 [4319] 6				26	
	20 [5.3]	145 [1283] 51	219 [1938] 50	269 [2381] 48	333 [2347] 45	408 [3611] 40	484 [4283] 35	548 [4850] 27			52	
	30 [7.9]	138 [1221] 76	215 [1903] 75	262 [2319] 73	322 [2850] 70	402 [3558] 67	472 [4177] 59	546 [4832] 47	625 [5531] 36		77	
	40 [10.6]	120 [1062] 103	204 [1805] 102	250 [2212] 100	310 [2743] 96	393 [3478] 89	458 [4053] 82	535 [4735] 73	618 [5469] 62		103	
	50 [13.2]	100 [885] 129	186 [1646] 128	238 [2106] 125	295 [2611] 123	374 [3310] 119	446 [3947] 112	520 [4602] 102	600 [5310] 91		129	
	60 [15.8]	76 [673] 155	166 [1469] 153	222 [1965] 150	282 [2496] 148	358 [3168] 143	427 [3779] 139	496 [4389] 130	576 [5097] 121		155	
	70 [18.5]	50 [442] 179	145 [1283] 177	194 [1717] 174	250 [2212] 170	334 [2956] 165	402 [3558] 158	472 [4177] 152	540 [4779] 144		180	
Max. Inter.	75 [19.8]	42 [372] 189	135 [1195] 187	176 [1558] 184	226 [2000] 180	306 [2708] 175	373 [3301] 167	445 [3938] 160	520 [4602] 150		190	
Rotor Width		Overall Efficiency - 70 - 100% <input type="checkbox"/> 40 - 69% <input type="checkbox"/> 0 - 39% <input checked="" type="checkbox"/>										
52.1 [2.050] mm [in]		Theoretical Torque - Nm [lb-in]										
		185 [1640]	278 [2460]	340 [3007]	402 [3554]	494 [4374]	587 [5194]	680 [6014]	772 [6834]			
		Displacement tested at 45°C [113°F] with an oil viscosity of 46cSt [213 SUS]										

► Performance data is typical. Performance of production units varies slightly from one motor to another. See page 10.03 for additional information on product testing.

WP Series

Light Duty Hydraulic Motor



WP (155/156 Series)

Light Duty Hydraulic Motor

HOUSINGS

► Dimensions shown are without paint. Paint thickness can be up to 0.13 [.005].

2-HOLE, SAE A MOUNT, ALIGNED PORTS

A10 1/2-14 NPT **A11** 7/8-14 UNF **A18** G 1/2 **A68** G 1/2 (TP)

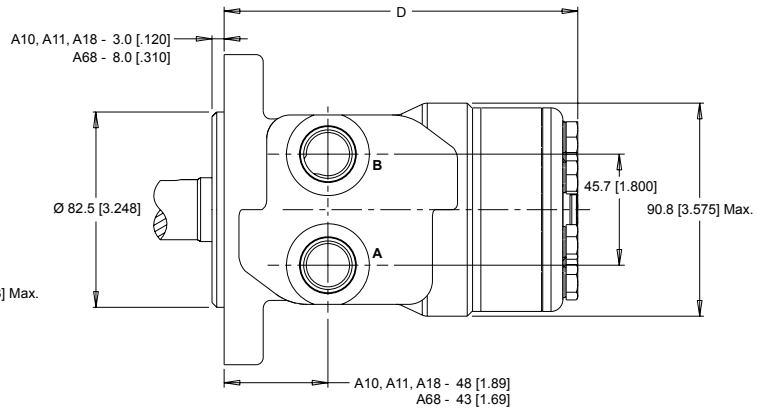
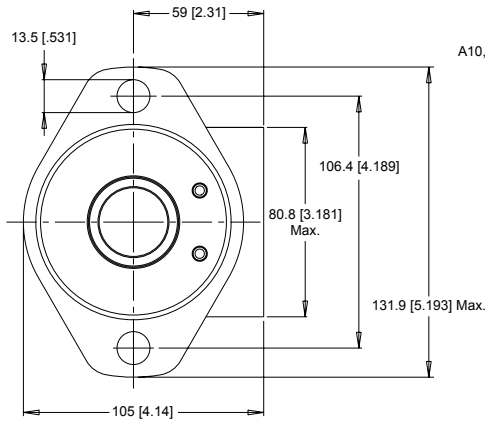

4-HOLE, MAGNETO MOUNT, ALIGNED PORTS

A30 1/2-14 NPT **A31** 7/8-14 UNF **AC8** G 1/2 (TP)

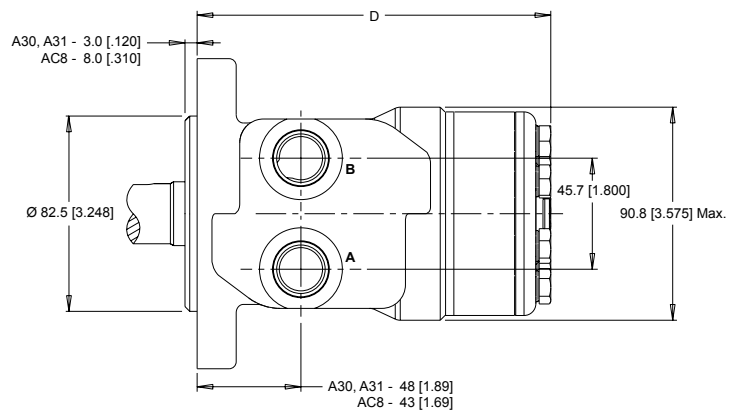
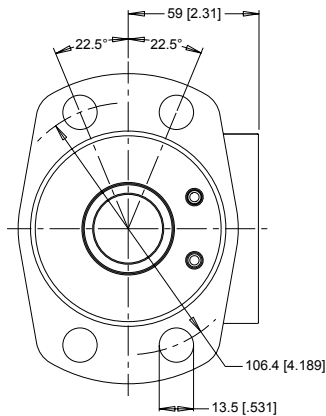

2-HOLE, SAE A MOUNT, OFFSET PORTS

A12 G 1/2 **A62** G 1/2 (TP) **A69** 7/8-14 UNF (TP)

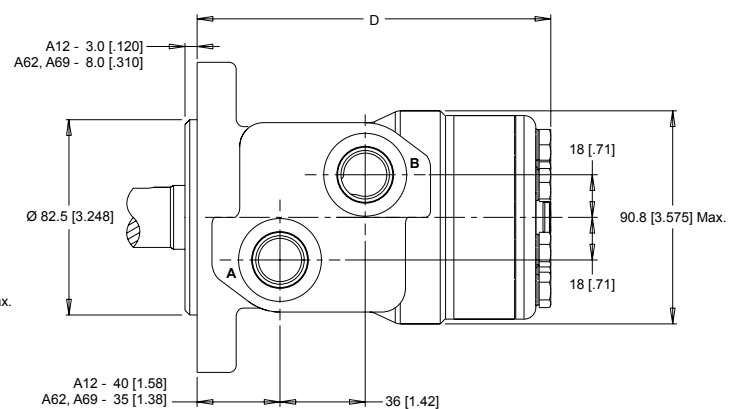
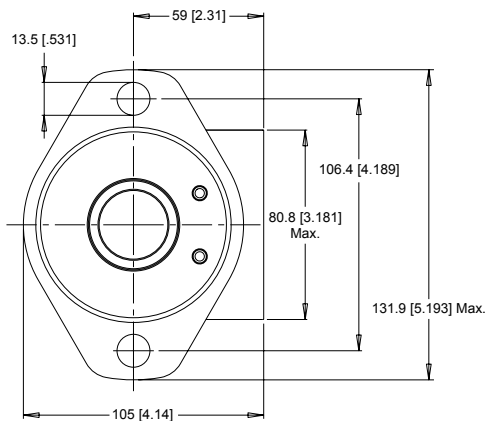

► Dimension D is charted on page 10.32. ► (TP) - Taller Pilot Height. Refer to detailed drawing for dimensional differences.

WP Series

Light Duty Hydraulic Motor



WP (155/156 Series) Light Duty Hydraulic Motor

HOUSINGS

► Dimensions shown are without paint. Paint thickness can be up to 0.13 [.005].

4-HOLE, MAGNETO MOUNT, OFFSET PORTS

A32 G 1/2

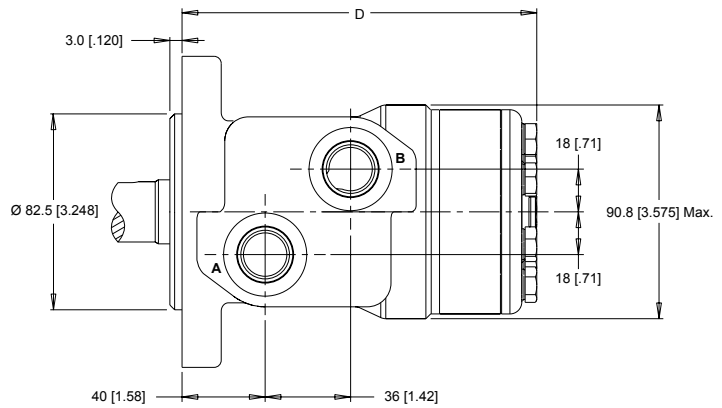
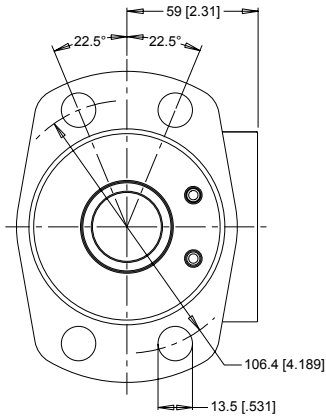

2-HOLE, SAE A MOUNT, ALIGNED MANIFOLD PORTS

A17 1/2" Drilled **G17** 1/2" Drilled

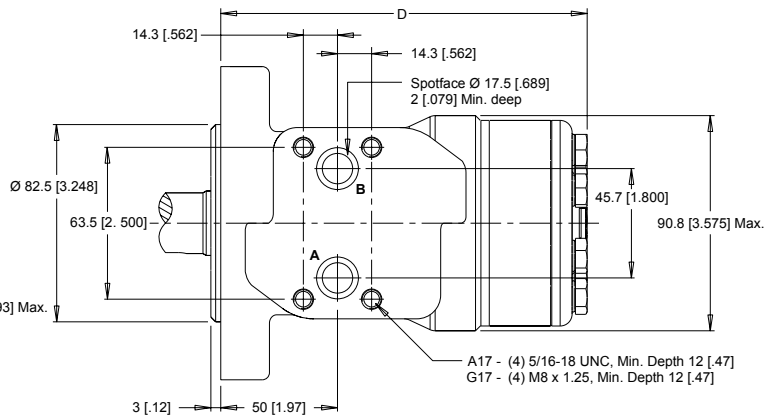
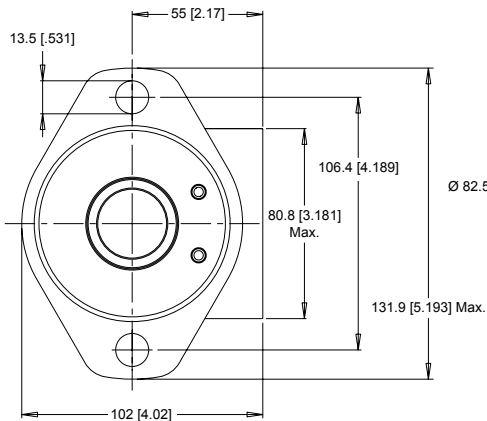

4-HOLE, MAGNETO MOUNT, ALIGNED MANIFOLD PORTS **A37** 1/2" Drilled **AC7** 1/2" Drilled (TP)

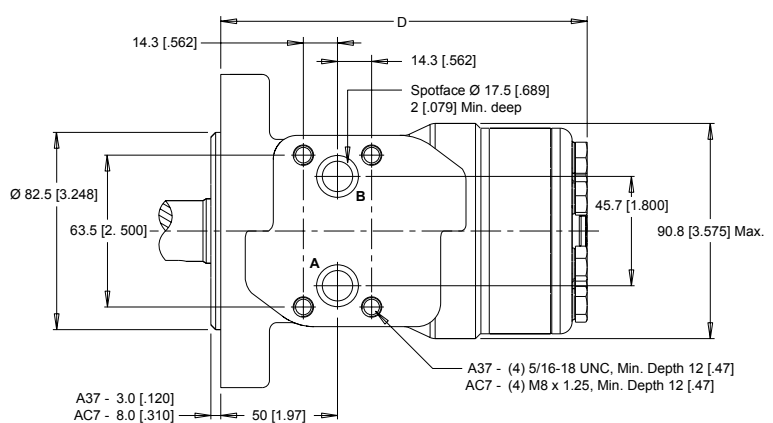
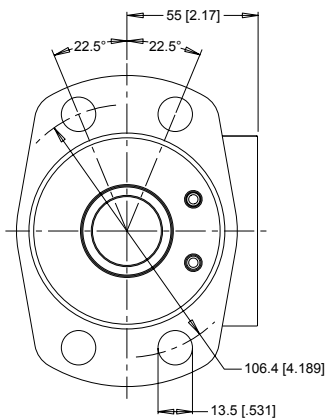

► Dimension D is charted on page 10.32. ► (TP) - Taller Pilot Height. Refer to detailed drawing for dimensional differences.

WP (155/156 Series)

Light Duty Hydraulic Motor

HOUSINGS

► Dimensions shown are without paint. Paint thickness can be up to 0.13 [.005].

2-HOLE, SAE A MOUNT, OFFSET MANIFOLD PORTS

A13 G 1/2

A63 G 1/2 (TP)

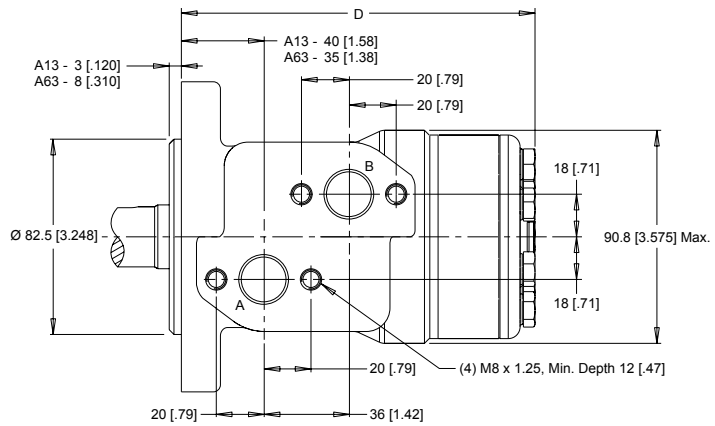
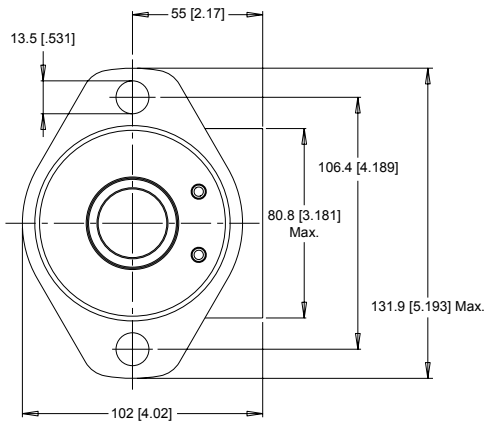

4-HOLE, MAGNETO MOUNT, OFFSET MANIFOLD PORTS

A3D 7/8-14 UNF

AC3 G 1/2 (TP)

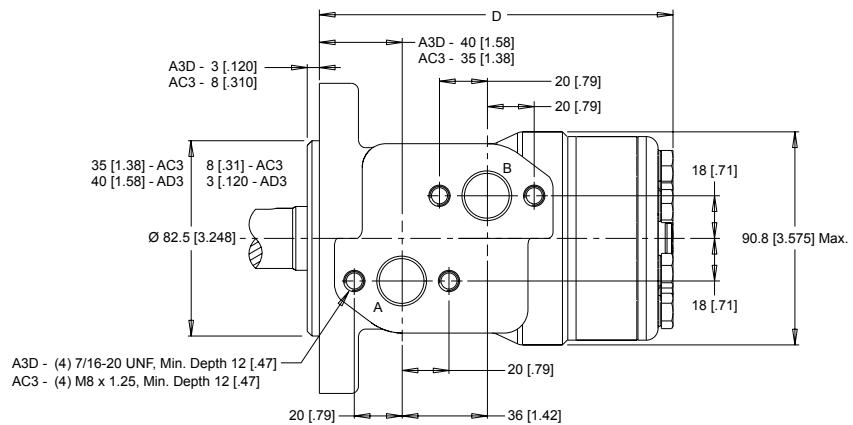
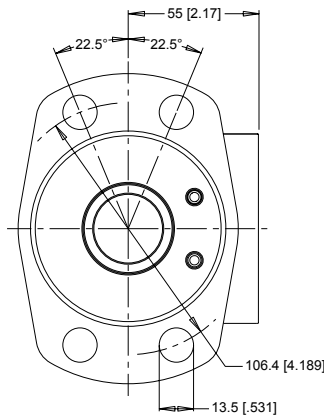

4-HOLE, SQUARE MOUNT, ALIGNED PORTS

F30 1/2-14 NPT

F31 7/8-14 UNF

F38 G 1/2

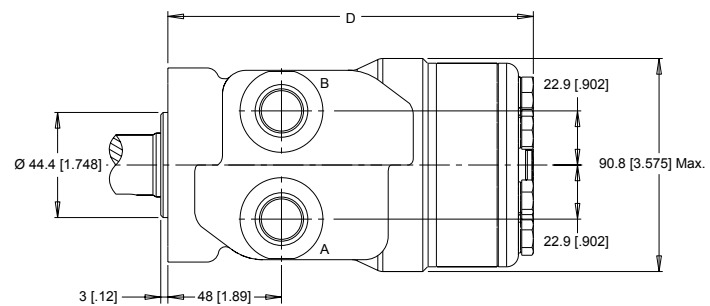
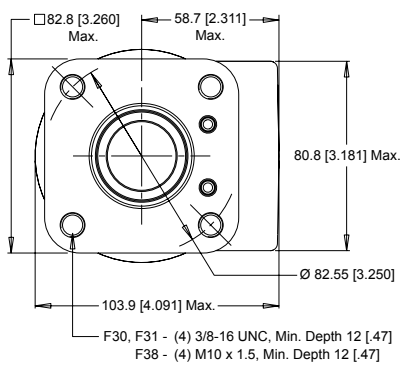

► Dimension D is charted on page 10.32. ► (TP) - Taller Pilot Height. Refer to detailed drawing for dimensional differences.

WP Series

Light Duty Hydraulic Motor



WP (155/156 Series) Light Duty Hydraulic Motor

HOUSINGS

► Dimensions shown are without paint. Paint thickness can be up to 0.13 [0.005].

4-HOLE, SQUARE MOUNT, ALIGNED MANIFOLD PORTS **F37** 1/2" Drilled

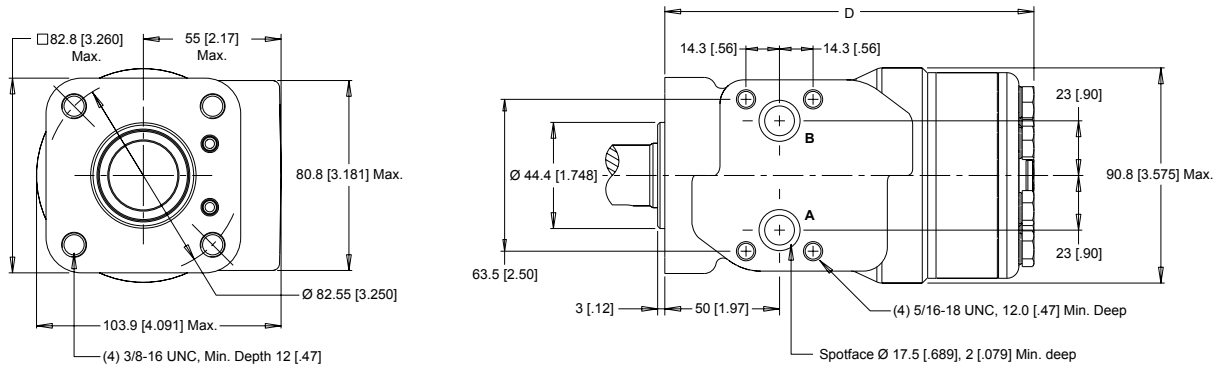

2-HOLE, SAE A MOUNT, OFFSET PORTS, VALVE CAVITY **A19** 7/8-14 UNF

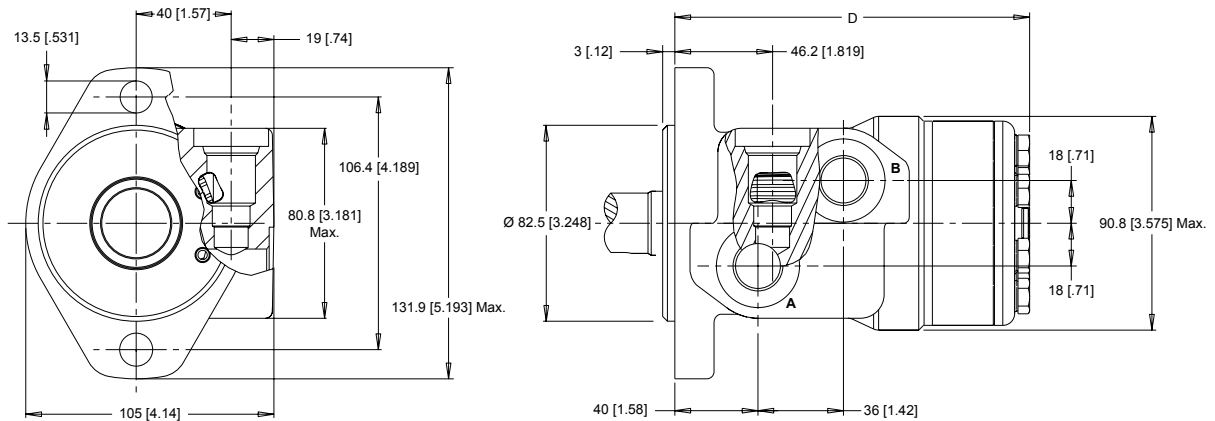

4-HOLE, MAGNETO MOUNT, OFFSET PORTS, VALVE CAVITY

A39 7/8-14 UNF **AC2** G 1/2 (TP)

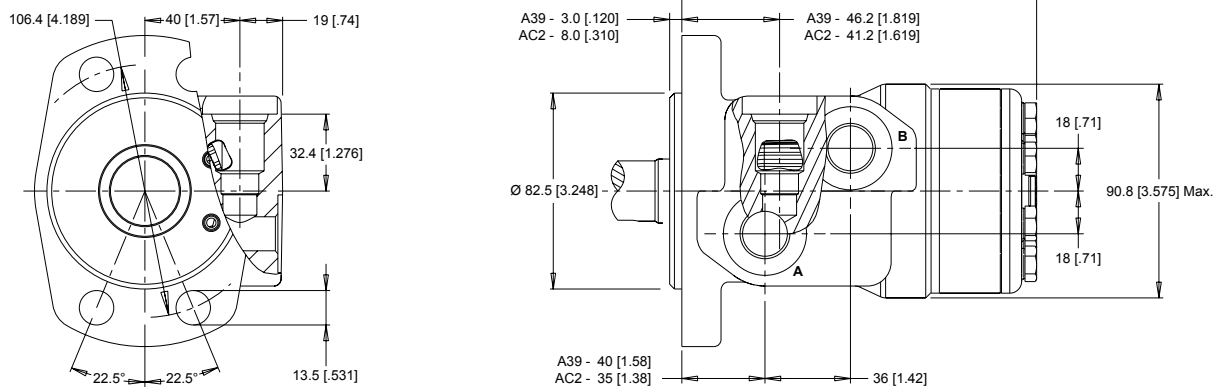

► Dimension D is charted on page 10.32. ► (TP) - Taller Pilot Height. Refer to detailed drawing for dimensional differences.

WP Series

Light Duty Hydraulic Motor



WP (155/156 Series) Light Duty Hydraulic Motor

HOUSINGS

2-HOLE, SAE A MOUNT, ALIGNED END PORTS

A06 3/4-16 UNF

A08 G 1/2

AP6 3/4-16 UNF (TP)

AP8 G 1/2 (TP)

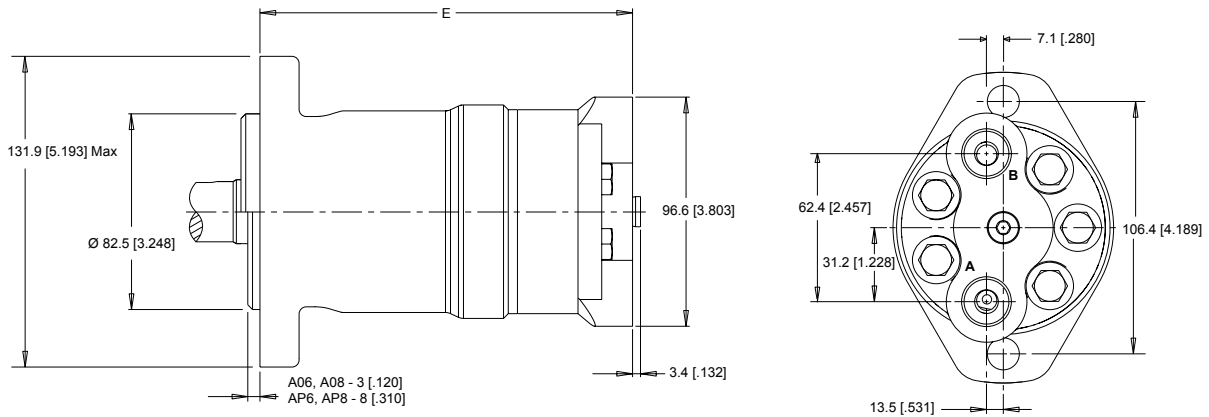

4-HOLE, SQUARE MOUNT, ALIGNED END PORTS

F21 7/8-14 UNF

F26 3/4-16 UNF

G24 M22 x 1.5

G28 G 1/2

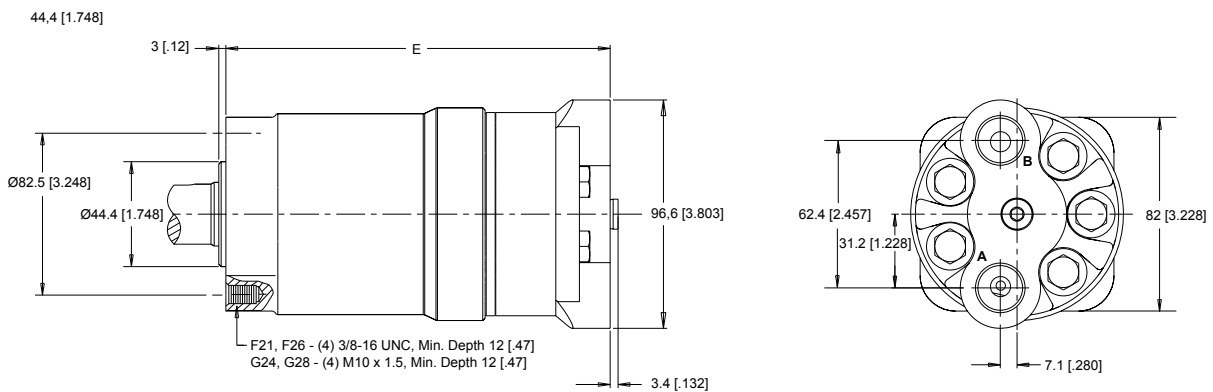

► Dimension E is charted on page 10.32. ► (TP) - Taller Pilot Height. Refer to detailed drawing for dimensional differences.

WP (155/156 Series) Light Duty Hydraulic Motor

TECHNICAL INFORMATION

ALLOWABLE SHAFT LOAD / BEARING CURVE

The bearing curve below represents the side load capacity of the motor at the centerline of the key for various motor speeds. Operating conditions within the shaded area will maintain acceptable oil film lubrication with recommended fluids. Operating conditions outside the shaded area are susceptible to motor failure due to oil starvation and/or excessive heat generation. Fluids with low lubricity or low viscosity may require the maximum load and speed ratings to be derated to provide acceptable motor life and performance.

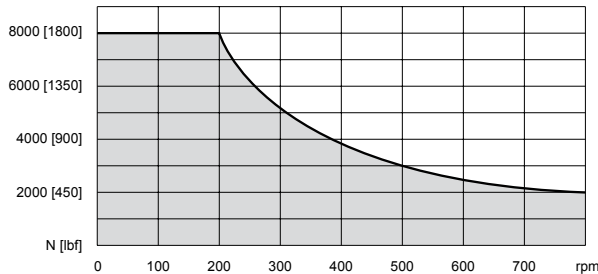

PERMISSIBLE SHAFT SEAL PRESSURE

The curve below represents allowable seal pressure at various speeds. Operation in the gray area results in maintaining the rated life of the shaft seal. Actual shaft seal pressure depends on motor configuration.

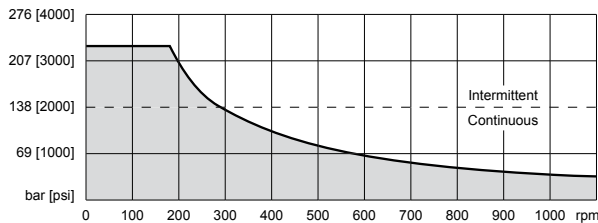

- ▶ With check valves and drain connection, the shaft seal pressure equals pressure in the drain line. With check valves and no drain connection, shaft seal pressure is identical to output pressure. No check valves and no drain connection, the shaft seal pressure is identical to the average value of input and output pressure.

THRUST LOAD

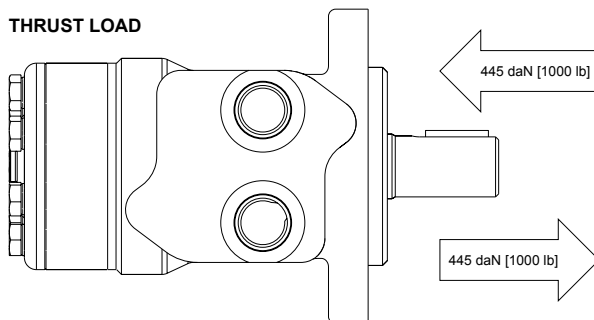

LENGTH & WEIGHT CHARTS

Dimension D is the overall motor length from the rear of the motor to the mounting flange surface and is referenced on detailed housing drawings listed on pages 10.27 - 10.30.

D	3mm Pilot	8mm Pilot	Weight
#	mm [in]	mm [in]	kg [lb]
025	133 [5.24]	128 [5.04]	6.3 [13.9]
032	134 [5.28]	129 [5.08]	6.4 [14.1]
040	136 [5.34]	131 [5.16]	6.5 [14.2]
050	136 [5.34]	131 [5.16]	6.5 [14.2]
060	137 [5.40]	132 [5.20]	6.5 [14.3]
080	139 [5.49]	134 [5.28]	6.6 [14.5]
100	142 [5.59]	137 [5.39]	6.7 [14.7]
125	146 [5.74]	141 [5.55]	6.8 [14.9]
160	150 [5.90]	145 [5.71]	6.9 [15.2]
200	155 [6.10]	150 [5.91]	7.1 [15.6]
250	162 [6.36]	157 [6.18]	7.3 [16.1]
315	170 [6.69]	165 [6.50]	7.6 [16.7]
400	181 [7.13]	176 [6.93]	7.9 [17.5]

Dimension E is the overall motor length from the rear of the motor to the mounting flange surface and is referenced on detailed housing drawings listed on pages 10.31.

E	3mm Pilot	8mm Pilot	Weight
#	mm [in]	mm [in]	kg [lb]
025	144 [5.67]	139 [5.47]	5.9 [13.0]
032	145 [5.71]	140 [5.51]	6.0 [13.2]
040	146 [5.75]	141 [5.55]	6.1 [13.4]
050	146 [5.75]	141 [5.55]	6.1 [13.4]
060	148 [5.83]	143 [5.63]	6.1 [13.4]
080	150 [5.91]	145 [5.71]	6.2 [13.6]
100	153 [6.02]	148 [5.83]	6.3 [13.9]
125	157 [6.18]	152 [5.98]	6.4 [14.1]
160	161 [6.33]	156 [6.14]	6.5 [14.3]
200	166 [6.54]	161 [6.34]	6.7 [14.7]
250	173 [6.81]	168 [6.61]	6.9 [15.2]
315	181 [7.13]	176 [6.93]	7.2 [15.8]
400	192 [7.56]	187 [7.36]	7.5 [16.5]

- ▶ The overall motor weights listed in each chart above were calculated using the heaviest of the housing options associated with that mounting flange to end of motor dimension. 155 & 156 series motor weights can vary ± 0.5 kg [1 lb] depending on model configurations such as housing, shaft, endcover, options etc.

WP (155/156 Series) Light Duty Hydraulic Motor

SHAFTS

01 7/8" 13 Tooth Spline

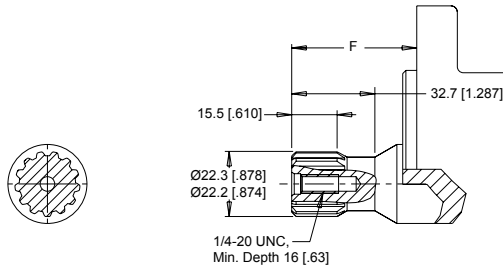

Max. Torque: 170 Nm [1500 lb-in]

12 25mm Straight

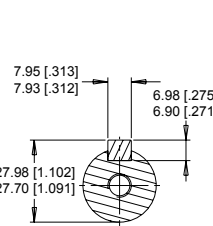

Max. Torque: 655 Nm [5800 lb-in]

16 25mm Straight Extended

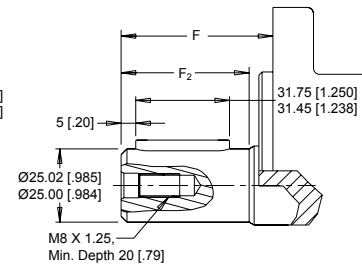

02 1" 6B Spline, 1/4-20 Tap

02, 04 - 6B Spline
SAE J499 Standard

F3 - 6B Spline
B.S. 2059 Standard



04 1" 6B Spline, M8x1.25 Tap

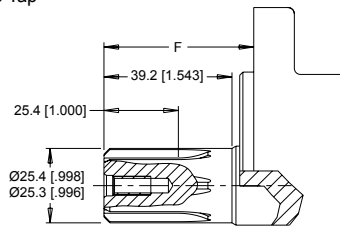

Max. Torque: 678 Nm [6000 lb-in]

B1 1" Straight, Woodruff Key

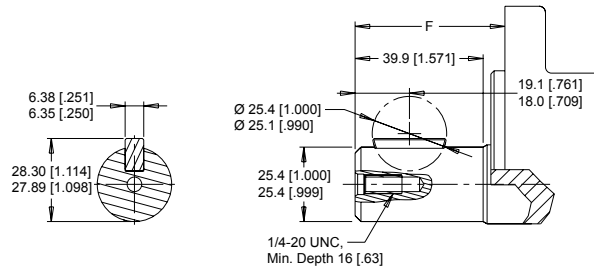

Max. Torque: 655 Nm [5800 lb-in]

05 1" - 9.5 [375] Pinhole

53 1" - 10.3 [406] Pinhole

66 1" - 8.0 [315] Pinhole

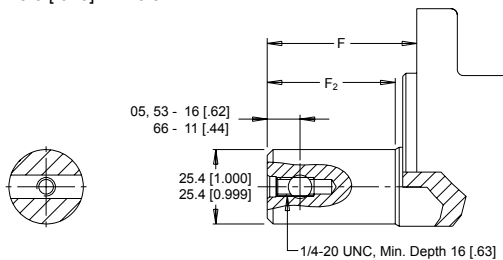

Max. Torque: 678 Nm [6000 lb-in]

10 1" Straight

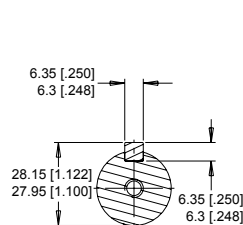

Max. Torque: 655 Nm [5800 lb-in]

15 1" Straight Extended

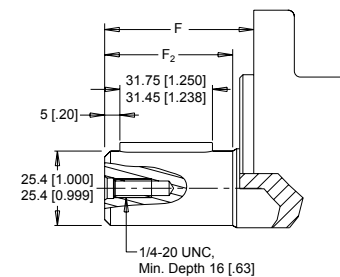

MOUNTING / SHAFT LENGTH CHART

Dimension F is the overall distance from the motor mounting surface to the end of the shaft.

Additional shaft length information, if necessary, is noted as F₂ and does not increase or decrease the listed F dimensions in this chart. The overall shaft lengths are already factored into the overall distance from the mounting surface to the end of the shaft.

F	3mm Pilot	8mm Pilot	F ₂
#	mm [in]	mm [in]	mm [in]
01	43.3 [1.705]	48.3 [1.902]	N/A
02	45.3 [1.783]	50.3 [1.980]	N/A
04	45.3 [1.783]	50.3 [1.980]	N/A
05	45.3 [1.783]	50.3 [1.980]	39.2 [1.543]
10	45.3 [1.783]	50.3 [1.980]	39.2 [1.543]
12	50.3 [1.980]	55.3 [2.177]	44.2 [1.740]
15	62.1 [2.445]	67.1 [2.642]	56.0 [2.205]
16	62.6 [2.464]	67.6 [2.661]	56.5 [2.225]
53	45.3 [1.783]	50.3 [1.980]	39.2 [1.543]
66	50.3 [1.980]	55.3 [2.177]	44.2 [1.740]
B1	45.3 [1.783]	50.3 [1.980]	N/A

WP (155/156 Series)

Light Duty Hydraulic Motor

ORDERING INFORMATION

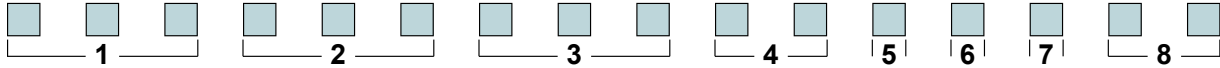

1. CHOOSE SERIES DESIGNATION

155 Clockwise Rotation

156 Counterclockwise Rotation

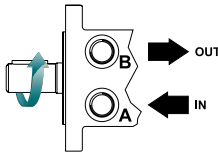
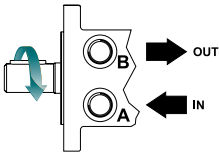

► The 155 & 156 series are bi-directional. Reversing the inlet hose will reverse shaft rotation.

2. SELECT A DISPLACEMENT OPTION

025	25 cm ³ /rev [1.5 in ³ /rev]	125	125 cm ³ /rev [7.6 in ³ /rev]
032	32 cm ³ /rev [2.0 in ³ /rev]	160	154 cm ³ /rev [9.4 in ³ /rev]
040	40 cm ³ /rev [2.5 in ³ /rev]	200	190 cm ³ /rev [11.6 in ³ /rev]
050	50 cm ³ /rev [3.0 in ³ /rev]	250	240 cm ³ /rev [14.6 in ³ /rev]
060	59 cm ³ /rev [3.6 in ³ /rev]	315	303 cm ³ /rev [18.5 in ³ /rev]
080	78 cm ³ /rev [4.8 in ³ /rev]	400	388 cm ³ /rev [23.7 in ³ /rev]
100	96 cm ³ /rev [5.9 in ³ /rev]		

3. SELECT A MOUNT & PORT OPTION

A06	2-Hole, SAE A Mount, Aligned End Ports, 3/4-16 UNF
A08	2-Hole, SAE A Mount, Aligned End Ports, G 1/2
AP6	2-Hole, SAE A Mount, Aligned End Ports, 3/4-16 UNF (TP)
AP8	2-Hole, SAE A Mount, Aligned End Ports, G 1/2 (TP)
A10	2-Hole, SAE A Mount, Aligned Ports, 1/2-14 NPT
A11	2-Hole, SAE A Mount, Aligned Ports, 7/8-14 UNF
A12	2-Hole, SAE A Mount, Offset Ports, G 1/2
A13	2-Hole, SAE A Mount, Offset Manifold Ports, G 1/2
A17	2-Hole, SAE A Mount, Aligned Manifold Ports, 1/2" Drilled
A18	2-Hole, SAE A Mount, Aligned Ports, G 1/2
A19	2-Hole, SAE A Mount, Offset Ports, Valve Cavity 7/8-14 UNF
A30	4-Hole, Magneto Mount, Aligned Ports, 1/2-14 NPT
A31	4-Hole, Magneto Mount, Aligned Ports, 7/8-14 UNF
A32	4-Hole, Magneto Mount, Offset Ports, G 1/2
A37	4-Hole, Magneto Mount, Aligned Manifold Ports, 1/2" Drilled
A39	4-Hole, Magneto Mount, Offset Ports, Valve Cavity 7/8-14 UNF
A3D	4-Hole, Magneto Mount, Offset Manifold Ports, 7/8-14 UNF
A62	2-Hole, SAE A Mount, Offset Ports, G 1/2 (TP)
A63	2-Hole, SAE A Mount, Offset Manifold Ports, G 1/2 (TP)
A68	2-Hole, SAE A Mount, Aligned Ports, G 1/2 (TP)
A69	2-Hole, SAE A Mount, Offset Ports, 7/8-14 UNF (TP)
AC2	4-Hole, Magneto Mount, Offset Ports, G 1/2 (TP)
AC3	4-Hole, Magneto Mount, Offset Manifold Ports, G 1/2 (TP)
AC7	4-Hole, Magneto Mount, Aligned Manifold Ports, 1/2" Drilled (TP)

► (TP) - Tall pilot, refer to pages 10.27- 10.30 for dimensional differences. Speed sensor option is not available on tall pilot housings.

3. SELECT A MOUNT & PORT OPTION

AC8	4-Hole, Magneto Mount, Aligned Ports, G 1/2 (TP)
F21	4-Hole, Square Mount, Aligned End Ports, 7/8-14 UNF
F26	4-Hole, Square Mount, Aligned End Ports, 3/4-16 UNF
F30	4-Hole, Square Mount, Aligned Ports, 1/2-14 NPT
F31	4-Hole, Square Mount, Aligned Ports, 7/8-14 UNF
F37	4-Hole, Square Mount, Aligned Manifold Ports, 1/2" Drilled
F38	4-Hole, Square Mount, Aligned Ports, G 1/2
G17	2-Hole, SAE A Mount, Aligned Manifold Ports, 1/2" Drilled
G24	4-Hole, Square Mount, Aligned End Ports, M22 x 1.5
G28	4-Hole, Square Mount, Aligned End Ports, G 1/2

4. SELECT A SHAFT OPTION

01	7/8" 13 Tooth Spline	15	1" Straight Extended
02	1" 6B Spline, 1/4-20 Tap	16	25mm Straight Extended
04	1" 6B Spline, M8x1.25 Tap	53	1" - 10.3 [.406] Pinhole
05	1" - 9.5 [.375] Pinhole	66	1" - 8.0 [.315] Pinhole
10	1" Straight	B1	1" Straight, Woodruff Key
12	25mm Straight	F3	1" 6B Spline, M8x1.25 Tap

► The 15 & 16 extended shafts are designed for use with one of the speed sensor options listed in STEP 7.

5. SELECT A PAINT OPTION

A	Black
B	Black, Unpainted Mounting Surface

6. SELECT A VALVE CAVITY / CARTRIDGE OPTION

A	None	F	121 bar [1750 psi] Relief
B	Valve Cavity Only	G	138 bar [2000 psi] Relief
C	69 bar [1000 psi] Relief	J	173 bar [2500 psi] Relief
D	86 bar [1250 psi] Relief	L	207 bar [3000 psi] Relief
E	104 bar [1500 psi] Relief		

► Valve cavity is only available on the A19, A39 & AC2 housings.

7. SELECT AN ADD-ON OPTION

A	Standard
B	Lock Nut
C	Solid Hex Nut
W	Speed Sensor, Dual, 4-Pin Male Weatherpack Connector
X	Speed Sensor, Dual, 4-Pin M12 Male Connector
Y	Speed Sensor, Single, 3-Pin Male Weatherpack Connector
Z	Speed Sensor, Single, 4-Pin M12 Male Connector

8. SELECT A MISCELLANEOUS OPTION

AA	None	FB	No Check Valves Installed
AC	Freeturning Rotor		