

SS Series

Oil Coolers



Features

OMT air/oil heat exchangers have been designed to use on the return line of hydraulic systems.

The special structure of the cooler element in alu-alloy increases the conductivity quality, and the brass welding process of the conduits allows a high thermic exchange and a good resistance to pressure, obtained by using qualified materials.

Materials

Fan	Steel or hard plastic
Fan case	Steel
Fan protection	Steel or hard plastic

Radiating Mass Data

Material	Aluminium
Nominal Pressure	25 bar
Test Pressure	35 bar
Maximum Temperature	120°C

Fluid Compatibility

Mineral oils, hl, hlp, water-oil emulsion

Installation

We recommend to install a by-pass valve in parallel to the heat exchanger, for its protection during start up. Ensure there are no obstacles to the air flow.

SS20 Series

Oil Coolers



Technical Features

Type	Frequency Hz	Voltage V	RPM	Power kW	Dia. Fan (mm)	dB (A)	L (mm)	Q Air (m3/h)	Cap. (lt)	Weight (kg)	IP
01	50/60	230	2600/2900	0.064/0.078	200	67	170	890	0.68	8	44
03	50/60	230/400	2600/2900	0.068/0.070	200	67	170	890	0.68	8	44
14	50/60	230/400	1370/1650	0.25	200	67	364	700	0.68	11	55
12	DC	12	3100	0.100	225	66	176	1200	0.68	7	65
24	DC	24	3000	0.100	225	66	176	1200	0.68	7	65
G2	-	-	-	-	200	-	-	-	-	7	-

Suggested oil flow from 30 to 100 (ltr/min)

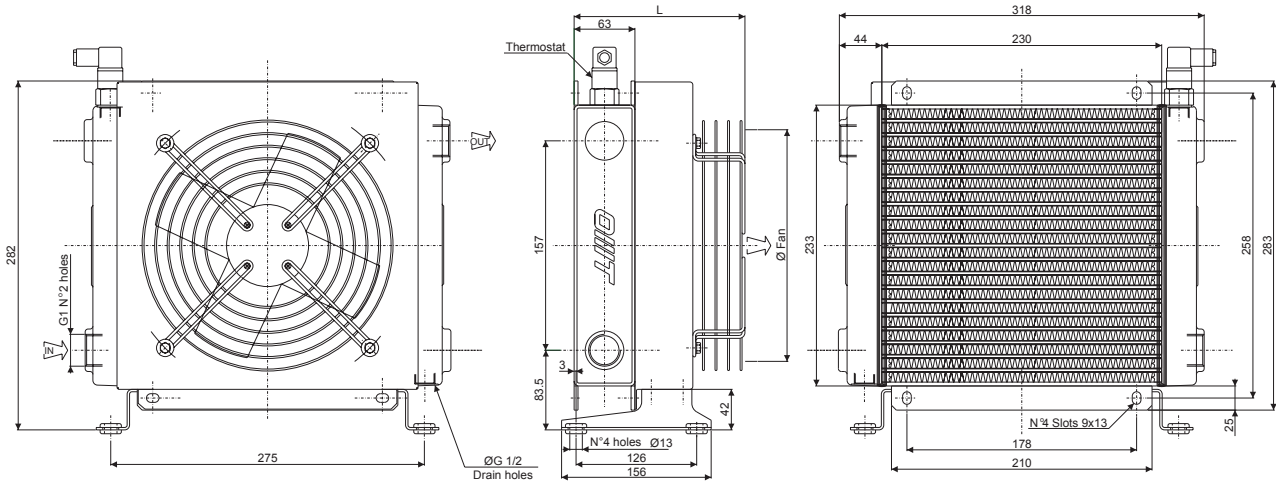

Correction Factor

CST	10	15	20	32	40	50	60	80	100	200
F	0.51	0.66	0.76	1	1.22	1.4	1.6	1.9	2.1	3.4

Performance Diagram

Pressure Drop Diagram (32 cst)

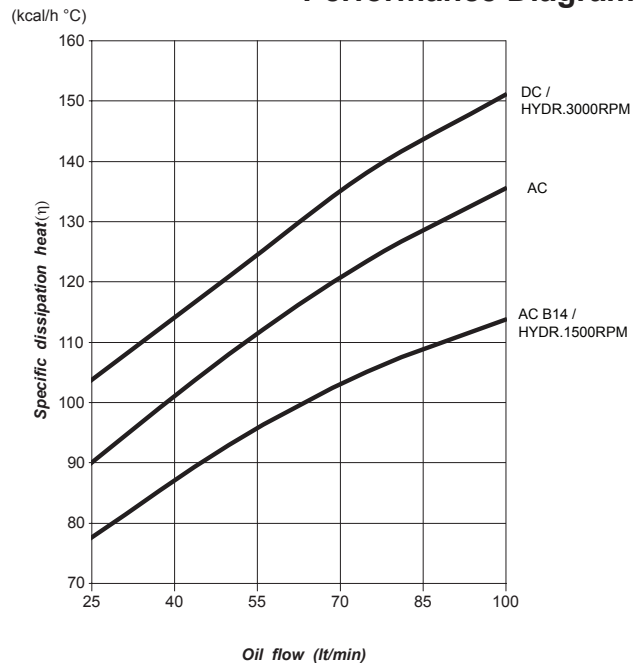
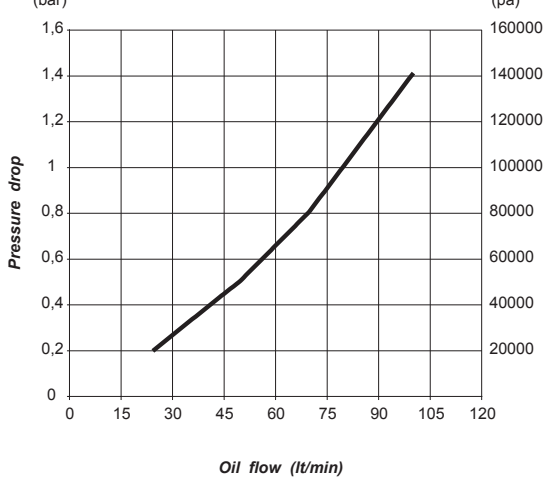

Bimetallic Fixed Temperature Switch

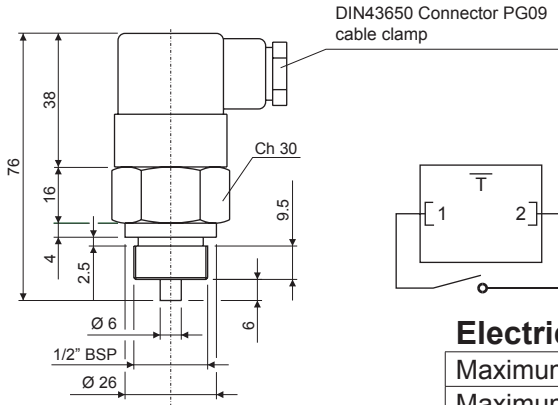

Stock Code	Working Temperature	Contact
T01	36-26°C	
T02	43-33°C	
T03	52-42°C	
T04	65-55°C	NA/NO
T05	75-65°C	
T06	85-75°C	
T07	95-85°C	

Electrical Data

Maximum voltage	250Vca
Maximum current	16A
Tolerance	±5°C
Maximum fixed hysteresis	15°C
Electrical connection	DIN43650
Protection degree	IP65
Maximum temperature	130°C

Materials

Body	Brass
Contacts	Silver plated

Temperature Switch

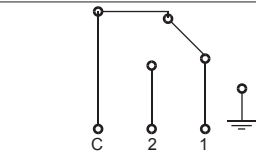
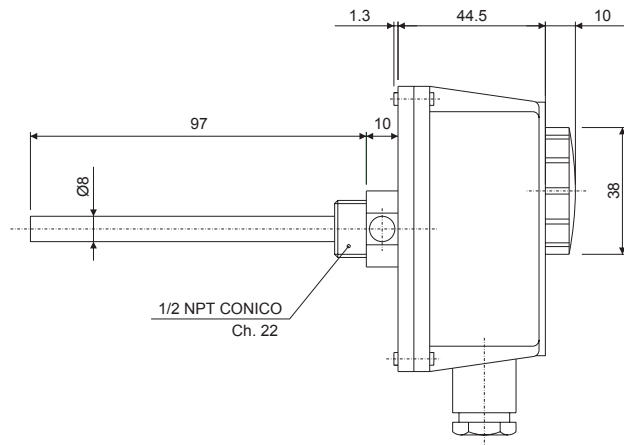
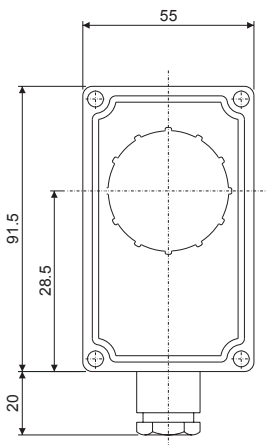

Morsetto 1: apre il circuito all'aumentare della temperatura
 Morsetto 2: chiude il circuito all'aumentare della temperatura
 Comune: entrata comune

Stock Code
T08

Electrical Data

Temperature range	0°±90°C
Tolerance	±5k
Temperature differential	6±2k
Degree of protection	IP40
Insulation class	I
Temperature rate of change	<1k/min
Maximum head temperature	80°C
Maximum sensing bulb temperature	125°C
Storage temperature	-15°C 55°C
Time constant	<1'
Contacts rating	C-1:10(2.5)A/250V~ C-2:6(2.5)A/250V~
Output	cutoff or switching contacts
Switch action	1B
Installation location	normal environment
Fairlead type	M20x1.5

How to Order

SS20	14	02	P
Type	Fan Motor		Foot flanges / Electric connection
SS10	01	230V 50/60 Hz Single Phase	P With foot flanges
SS15	03	230/400V 50/60 Hz three phase	E With electric connection
SS20	14	230/400V 50/60 Hz three phase B14	PE With foot flanges and electric connection
SS24	12	12V CC	
SS30	24	24V CC	
	G2	Arranged for hydraulic motor GR.2	
		Bimetallic fixed temperature switch	
		00 No Switch	
		01 Fixed switch 36-26°C	
		02 Fixed switch 43-33°C	
		03 Fixed switch 52-42°C	
		04 Fixed switch 65-55°C	
		05 Fixed switch 75-65°C	
		06 Fixed switch 85-75°C	
		07 Fixed switch 95-85°C	
		Adjustable switch	
		08 Adjustable switch 0-90°C	