

C2 21/28 Series

Axial Piston Pumps Variable Displacement



FEATURES

The C2 21/28 Series is a family of variable displacement axial piston pumps for use in closed circuits. The displacement is continuously variable by means of a tilting swash plate and the oil flow direction is reversible.

The following range of controls are available:

- Automotive
- Hydraulic proportional without feed-back
- Hydraulic proportional with feed-back
- Manual lever with feed-back
- Manual with zeroing
- Electric two position (ON-OFF)
- Electric impulse
- Electric proportional with feed-back
- Electric proportional without feed-back

Peak operations must not exceed 1% of every minute. A simultaneous maximum pressure and maximum speed are not recommended.



Two through drive options for auxiliary pump mounting and two options are available:

- Pressure filter
- Filter with electrical clogging sensor
- Power limiter
- Exchange valve
- Electric cut-off valve
- Hydraulic inching
- Mechanical inching
- Through drive - SAE 'A' 9T - 16/32-DP
- Through drive - SAE 'B' 13T - 16/32-DP
- Through drive - SAE 'B-B' 15T - 16/32-DP

TECHNICAL DATA

SERIES		C2
Displacement ⁽¹⁾	cc/rev	21 - 28 (1.28 - 1.71)
Connection flange		SAE 'B'
Charge pump displacement	cc/rev	11 (0.671)
Maximum speed ⁽²⁾	rpm	3600
Minimum speed	rpm	700
Rated pressure	bar (psi)	250 (3635)
Peak pressure	bar (psi)	350 (5089)
Charge pressure	bar (psi)	15÷25 (standard 20) (218÷363) (standard 290)
Maximum case pressure	bar (psi)	2 (29)
Suction pressure	bar (psi)	≥ 0.8 (≥ 11.6)
Moment of inertia rotating parts	kg m ² (lb ft ²)	0.0018 (0.042)
Weight (approx.)	kg (lb)	27 (48.5)

Notes:

(1) The displacements 21/28 use the same external casing.

(2) The values shown are valid for an absolute pressure (pass) of 1 bar (14.5 psi) at the suction inlet port and when operated on mineral oil.

C2 21/28 Series



Axial Piston Pumps Variable Displacement

MODEL CODE	1	2	2A	3	4	5	6	7	8	9	10

10: Omit if not required

1 - SERIES

C2	Variable displacement axial piston pump for closed circuit "MEDIUM PRESSURE"
-----------	--

2 - DISPLACEMENT

21	Displacement 21 cm ³
28	Displacement 28 cm ³

2A - DISPLACEMENT LIMITATION

3 - CONTROLS

AM2	Automotive 12V
AM4	Automotive 24V
IND	Hydraulic proportional without feed-back
INP	Hydraulic proportional without feed-back
E12	Electric impulse 12V
E14	Electric impulse 24V
IRX	Hydraulic proportional with feed-back
LRX	Manual lever with feed-back
LNx	Manual with zeroing
LWx	Manual without zeroing
E22	Electric two position ON-OFF 12V
E24	Electric two position ON-OFF 24V
ER2	Electric proportional with feed-back 12V
ER4	Electric proportional with feed-back 24V
EP2	Electric proportional without feed-back 12V
EP4	Electric proportional without feed-back 24V
EH2	Electric proportional with feed-back 12V & Hydraulic proportional with feed-back
EH4	Electric proportional with feed-back 24V & Hydraulic proportional with feed-back

C2 21/28 Series

Axial Piston Pumps Variable Displacement



4 - THROUGH DRIVE

		SHAFT END					
		1	2	3	4	5	6
1	Without through drive with charge pump	•			•	•	•
2	Without through drive without charge pump	•				•	•
3	SAE A = Z9 - 16/32 DP with charge pump	•			•	•	•
4	SAE B = Z13 - 16/32 DP with charge pump			•			
5	Pump combination (Short version)		•				
6	SAE A = Z9 - 16/32 DP without charge pump	•			•	•	•
7	SAE B = Z13 - 16/32 DP without charge pump			•			
8	Pump combination c/w through drive SAE A = 9T - 16/32 DP (C1)	•				•	•
9	Pump combination c/w through drive SAE B = 13T - 16/32 DP (C2) (C3)			•			
10⁽¹⁾	SAE B-B = Z15 - 16/32 DP			•			

Note: (1) With coupling Internal Splined T13 / Internal Splined T15

5 - PRESSURE RELIEF VALVE

14	140 bar - (2030 psi)
17	170 bar - (2465 psi)
21	210 bar - (3045 psi)
25	250 bar - (3625 psi) (Standard)
30	300 bar - (4350 psi)
35	350 bar - (5075 psi)

6 - DIRECTION OF ROTATION

R	CW
L	CCW

C2 21/28 Series



Axial Piston Pumps Variable Displacement

7 - SHAFT END		Single	1a Tandem	2a Tandem
1⁽¹⁾	Splined T9-16/32-DP / Splined T9-16/32-DP (SAE A)	•	•	•
2⁽²⁾	Splined T9-16/32-DP / Bosch	•	•	
3⁽³⁾	Internal splined T9-16/32-DP / Tandem Bosch	•	•	•
4⁽⁴⁾	Internal splined T9-16/32-DP / Tandem	•	•	•
5⁽⁵⁾	Round shaft Ø15.88 / Splined T9-16/32-DP	•	•	
6⁽¹⁾	Round shaft Ø24 / Splined T9-16/32-DP	•	•	•

Note:

(1) Used for Single pump.

Used for first pump Tandem 21/28 + 14/18 with through drive SAE A.

Used for second pump Tandem 21/28 + 21/28.

Used for second pump Tandem 50/64 + 21/28.

(2) Used for first pump Tandem 21/28 + 21/28 short version.

(3) Used for Single pump with through drive SAE B.

Used for first pump Tandem 21/28 + 21/28 with through drive SAE B.

Used for second pump Tandem 50/64 + 21/28 with through drive SAE B.

(4) Used for second pump Tandem 21/28 + 21/28 short version.

(5) Used for Single pump with through drive SAE A.

Used for first pump Tandem 21/28 + 14/18 with through drive SAE A.

8 - PORTS

G	Metric (BSPP Threads)
U	SAE (UNF Threads)

9 - OPTIONS

00	Without options
AC	C.T. Distribution (Motor swash plate)
FI	With Filter
FE	Filter with Electric sensor
FR	Remote mounted filter
01	Power Limiter
P1	Electric Cut-Off Valve 12V
P2	Electric Cut-Off Valve 24V
VS	Exchange Valve
II	Hydraulic inching
IM	Mechanical inching

10 - SPECIAL VERSIONS

C2 21/28 Series

Axial Piston Pumps Variable Displacement



AUTOMOTIVE CONTROL - AM2 / AM4

The automotive control pump has the function of automatically adapting the displacement to the variation in the number of revolutions of the pump (and thus of the diesel engine); set the number of revolutions at which the machine starts up and limit the power absorbed by the transmission to the diesel engine output. The inching valve (variable restrictor) is available as an option, with mechanical or hydraulic control versions.

HYDRAULIC INCHING

Automotive Control

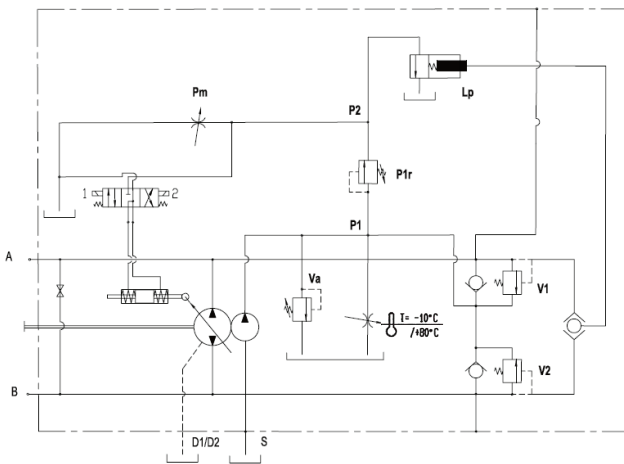

Automotive Control with Hydraulic Inching

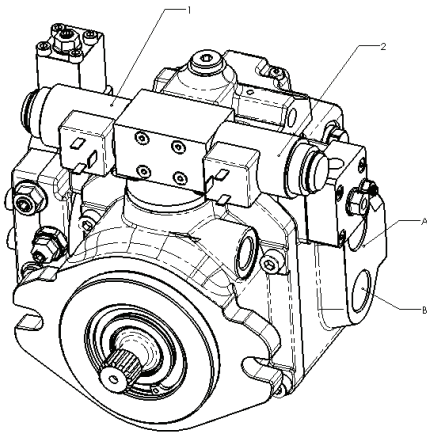
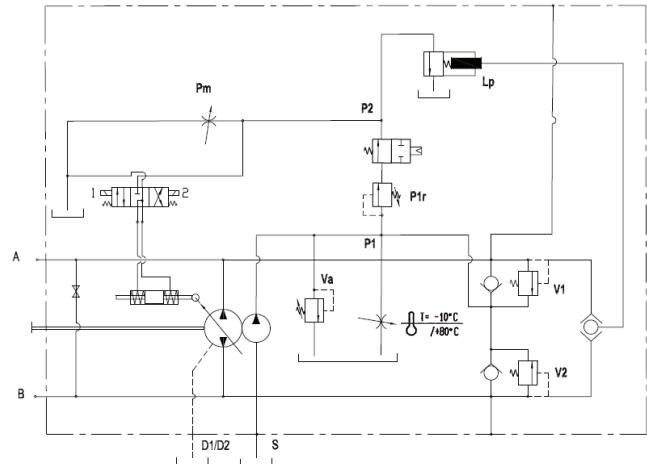

Direction of rotation: Correlation between direction of rotation (shaft view) control and direction of flow.

SHAFT ROTATION	PUMP FLOW DIRECTION	
	Energised Solenoid	Pressure Port
(L)	1	B
	2	A
(R)	1	A
	2	B

C2 21/28 Series

Axial Piston Pumps Variable Displacement



PUMP AND CONTROL DIMENSION - AM2 / AM4

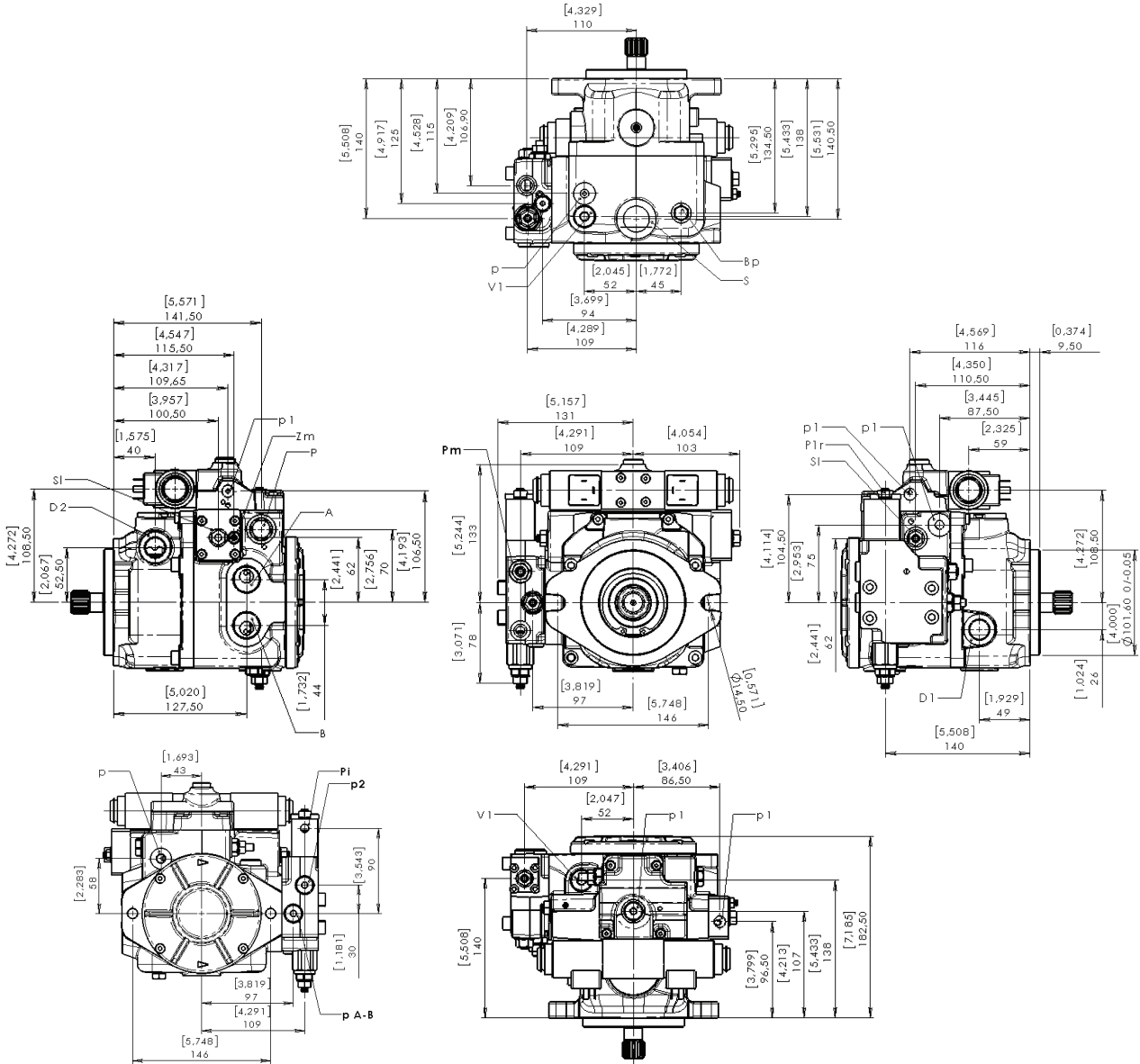

METRIC Version

- A - B: Pressure ports - 3/4 G
- D1 - D2: Drain port - 1/2 G
- S: Suction port - 3/4 G
- P: Charge pressure port - 3/4-16 UNF-2B -> 1/4 G
- Va: Charge pump valve
- V1 - V2: Maximum pressure valves
- Sl: Stroke limiter
- Zm: Mechanical zero adjustment screw
- p: Charge pressure ports - 1/8 G
- p1: a - b piloting ports - 1/4 G
- Pi: Inching In - 1/8 G
- Lp: Power control adjusting screw
- Pm: Machine start-up regulation screw
- P1r: Minimum charge pressure adjusting screw
- P2: Piloting pressure port - 1/4 "G
- P A-B: High pressure port (A-B) - 1/4 "G

SAE Version

- A - B: Pressure ports - 7/8-14 UNF-2B
- D1 - D2: Drain port - 3/4-16 UNF-2B
- S: Suction port - 1 1/16 UNF-2B
- P: Charge pressure port - 3/4-16 UNF-2B -> 7/16-20 UNF-2B
- Va: Charge pump valve
- V1 - V2: Maximum pressure valves
- Sl: Stroke limiter
- Zm: Mechanical zero adjustment screw
- p: Charge pressure ports - 3/8-24 UNF-2B
- p1: a - b piloting ports - 7/16-20 UNF-2B
- Pi: Inching In - 3/8-24 UNF-2B
- Lp: Power control adjusting screw
- Pm: Machine start-up regulation screw
- P1r: Minimum charge pressure adjusting screw
- P2: Piloting pressure port - 7/16-20 UNF-2B
- P A-B: High pressure port (A-B) - 7/16-20 UNF-2B

C2 21/28 Series

Axial Piston Pumps Variable Displacement



AUTOMOTIVE CONTROL - AM2 / AM4

The automotive control pump has the function of automatically adapting the displacement to the variation in the number of revolutions of the pump (and thus of the diesel engine); set the number of revolutions at which the machine starts up and limit the power absorbed by the transmission to the diesel engine output. The inching valve (variable restrictor) is available as an option, with mechanical or hydraulic control versions.

MECHANICAL INCHING

Automotive Control

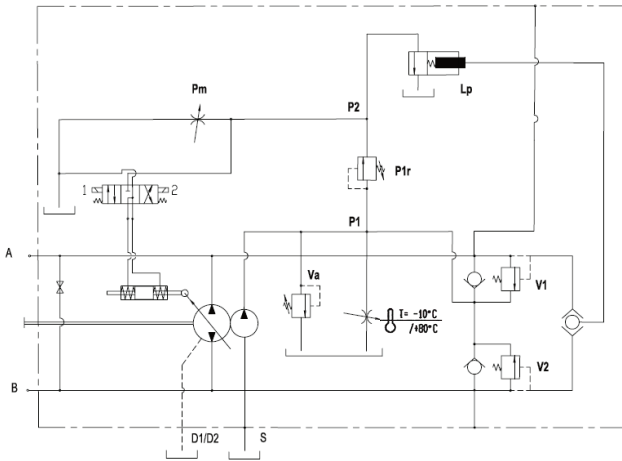

Automotive Control with Mechanical Inching

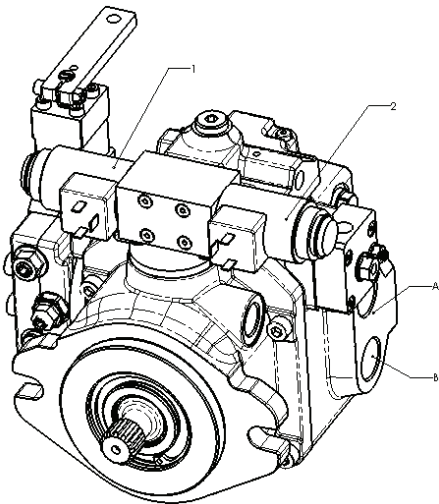
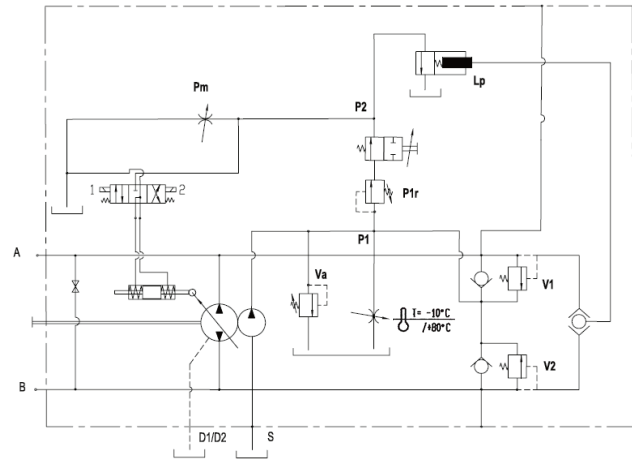

Direction of rotation: Correlation between direction of rotation (shaft view) control and direction of flow.

SHAFT ROTATION	PUMP FLOW DIRECTION	
	Energised Solenoid	Pressure Port
(L)	1	B
	2	A
(R)	1	A
	2	B

C2 21/28 Series

Axial Piston Pumps Variable Displacement



HYDRAULIC PROPORTIONAL WITHOUT FEED-BACK CONTROL - IND

The pump displacement is proportional to the pilot pressure on “a” or “b” piloting ports, which also affect flow direction. Feeding pressure to the control joystick can be provided by charge pressure from p port. The piloting pressure must then be controlled by said joystick or by a pressure reducing valve (not supplied).

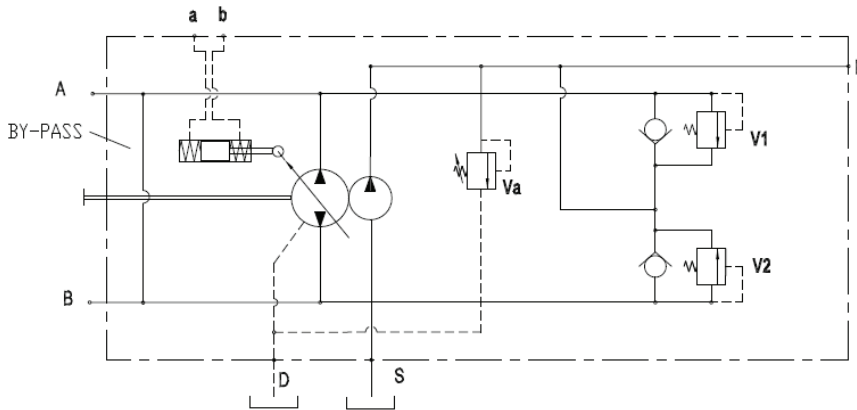

Pilot pressure = 4÷16 bar [58÷232 psi]
(at ports a,b)

Start of control = 4 bar [58 psi]

End of control = 16 bar [232 psi]
(Maximum displacement)

Max pressure = 30 bar [435 psi]

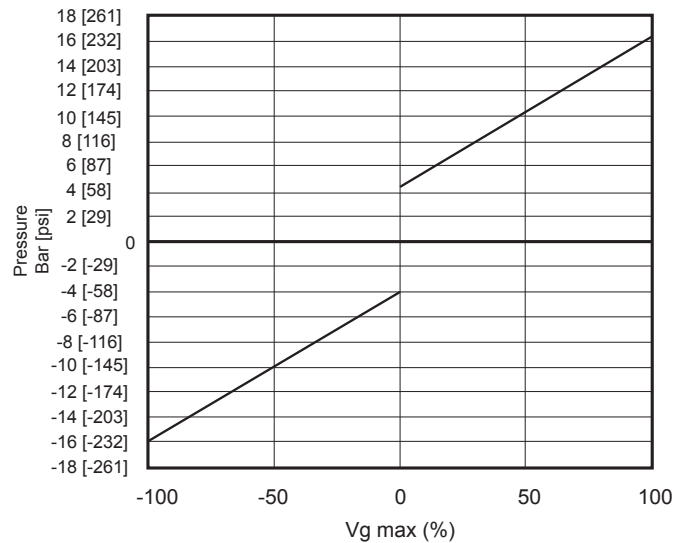

Direction of rotation: Correlation between direction of rotation (shaft view) control and direction of flow.

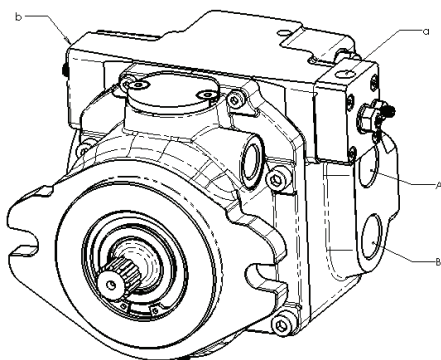

SHAFT ROTATION	PUMP FLOW DIRECTION	
	Piloting Pressure	Pressure Port
(L)	a	A
	b	B
(R)	a	B
	b	A

C2 21/28 Series

Axial Piston Pumps Variable Displacement



PUMP AND CONTROLS DIMENSION - IND

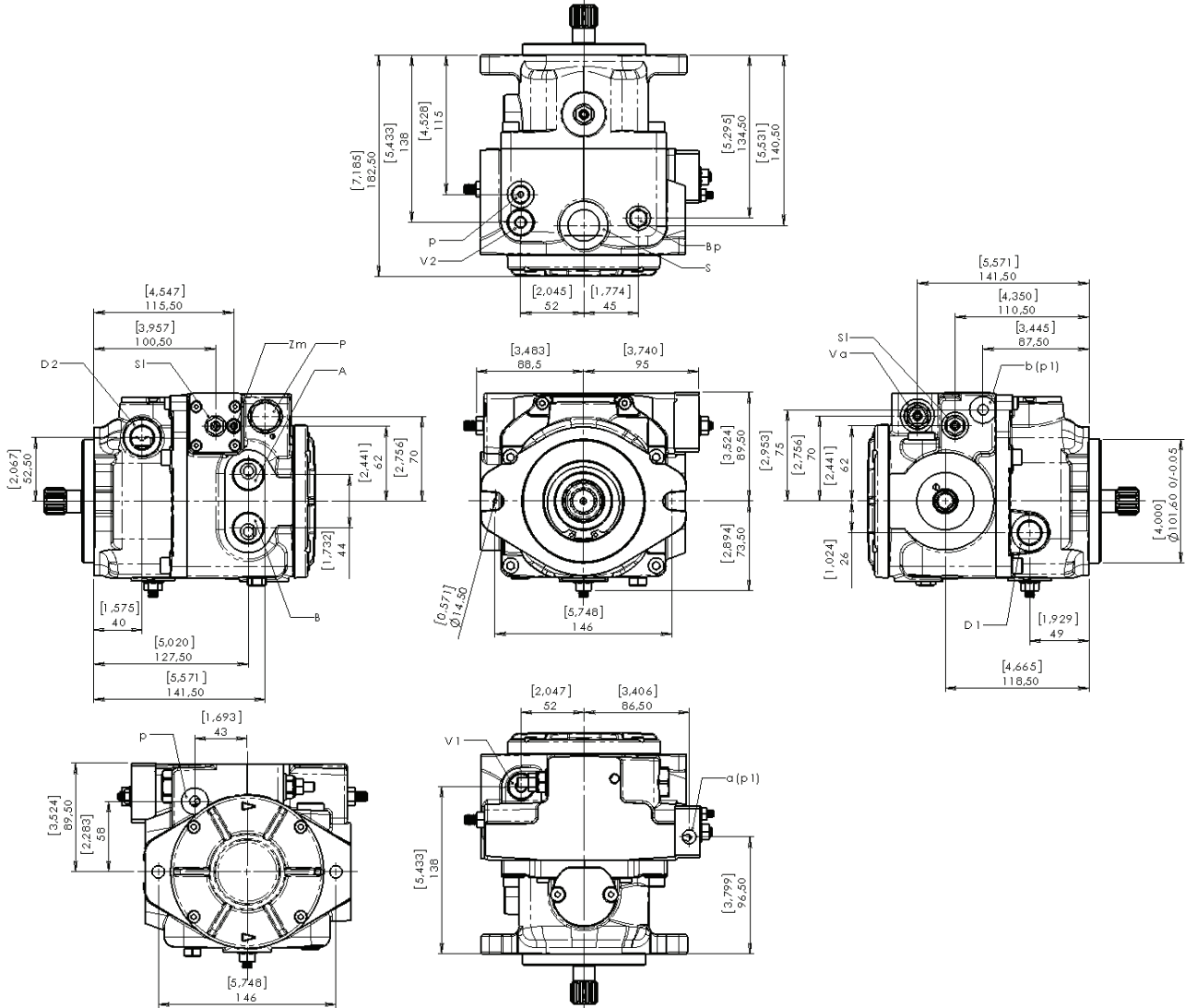

METRIC Version

A – B: Pressure ports – 3/4 G
 D1 – D2: Drain port – 1/2 G
 S: Suction port – 3/4 G
 P: Charge pressure port – 3/16 UNF-2B -> 1/4 G
 Va: Charge pump valve
 V1 – V2: Maximum pressure valves
 Sl: Stroke limiter
 Zm: Mechanical zero adjustment screw
 a – b: Control piloting pressure port – 1/8 G
 p: Ports – 1/8 G
 p1: Ports – 1/4 G

SAE Version

A – B: Pressure ports – 7/8-14 UNF-2B
 D1 – D2: Drain port – 3/4-16 UNF-2B
 S: / Suction port – 1 1/16 UNF-2B
 P: Charge pressure port – 3/16 UNF-2B -> 7/16-20 UNF-2B
 Va: Charge pump valve
 V1 – V2: Maximum pressure valves
 Sl: Stroke limiter
 Zm: V Mechanical zero adjustment screw
 a – b: Control piloting pressure port – 3/8-24 UNF-2B
 p: Ports – 3/8-24 UNF-2B
 p1: Ports – 7/16-20 UNF-2B

C2 21/28 Series

Axial Piston Pumps Variable Displacement



HYDRAULIC PROPORTIONAL WITHOUT FEED-BACK CONTROL - INP

The pump displacement is proportional to the pilot pressure on “a” or “b” piloting ports, which also affect flow direction. Feeding pressure to the control joystick can be provided by charge pressure from p port. The piloting pressure must then be controlled by said joystick or by a pressure reducing valve (not supplied).

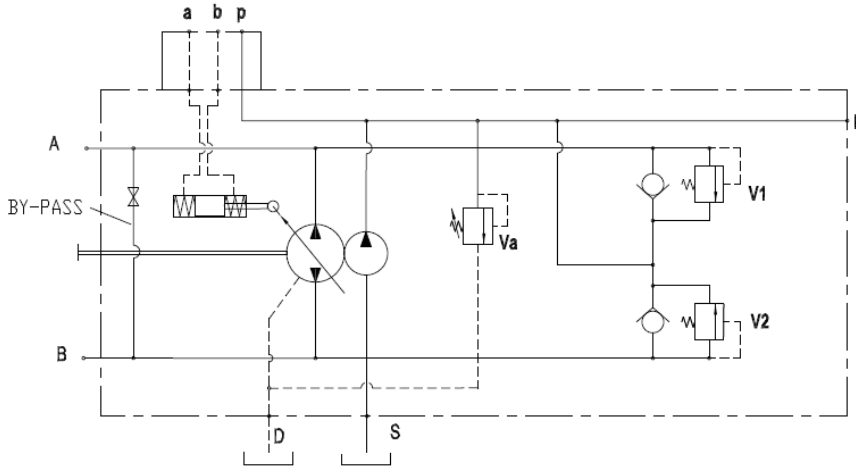

Pilot pressure = 4÷16 bar [58÷232 psi]
(at ports a,b)

Start of control = 4 bar [58 psi]

End of control = 16 bar [232 psi]
(Maximum displacement)

Max pressure = 30 bar [435 psi]

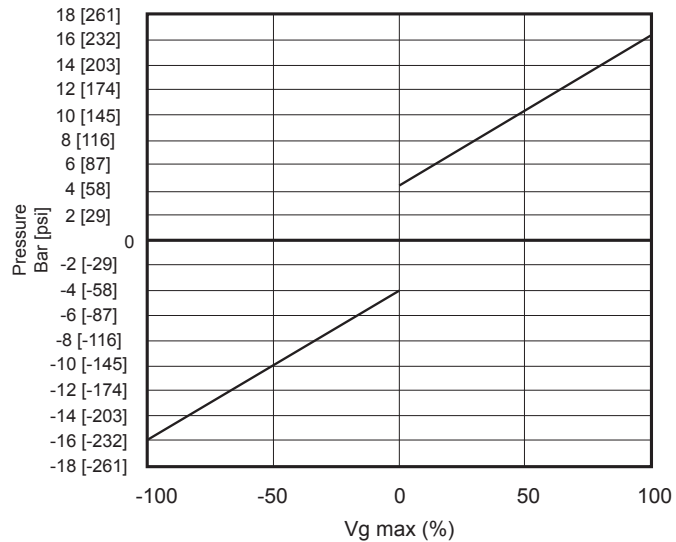

Direction of rotation: Correlation between direction of rotation (shaft view) control and direction of flow.

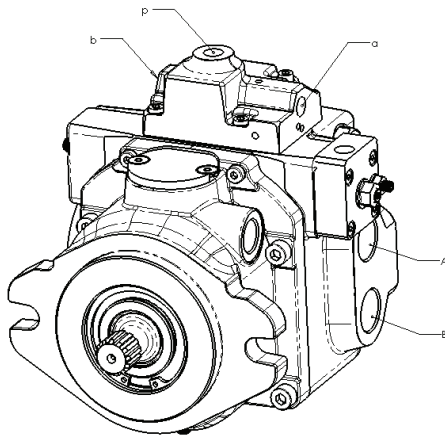

SHAFT ROTATION	PUMP FLOW DIRECTION	
	Piloting Pressure	Pressure Port
(L)	a	A
	b	B
(R)	a	B
	b	A

C2 21/28 Series

Axial Piston Pumps Variable Displacement



ELECTRIC IMPULSE CONTROL - E12/E14

Impulse control where the displacement of the pump is function of the number of inputs of current to one of the two proportional solenoids. The servo control is without zeroing spring, therefore the piston of the servo control stays in the position until a new input of current is fed to the solenoids. Flow direction depends on which solenoid is energised. Standard solenoids are ON-OFF at 24V DC max. current 1A. (Optional solenoids 12V DC max. current 2A).

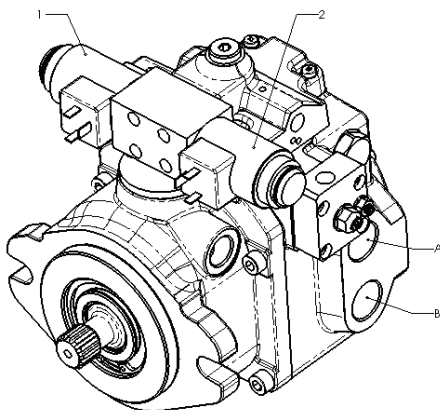
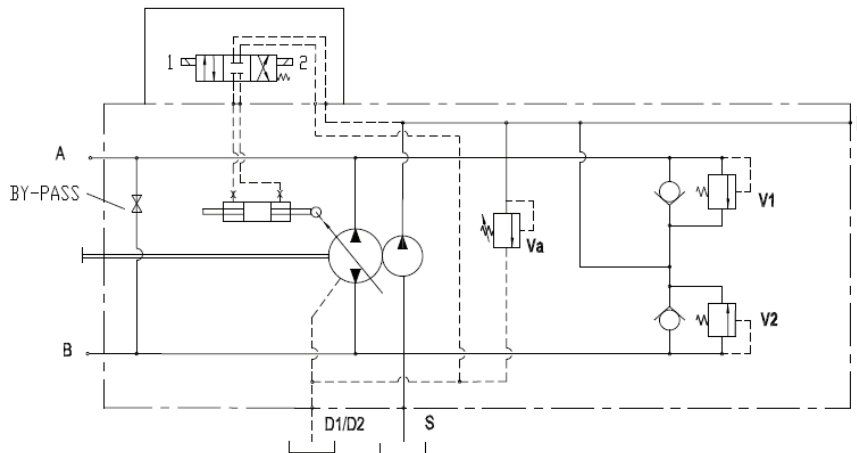

Direction of rotation: Correlation between direction of rotation (shaft view) control and direction of flow.

SHAFT ROTATION	PUMP FLOW DIRECTION	
	Energised Solenoid	Pressure Port
(L)	1	B
	2	A
(R)	1	A
	2	B

C2 21/28 Series

Axial Piston Pumps Variable Displacement



HYDRAULIC PROPORTIONAL WITH FEED-BACK CONTROL - IRX

The pump displacement is proportional to the pilot pressure on “a” or “b” ports; which also affect flow direction. Piloting can be provided by charge pressure from P port. The piloting pressure will then have to be controlled by a joystick or by a pressure reducing valve (not supplied).

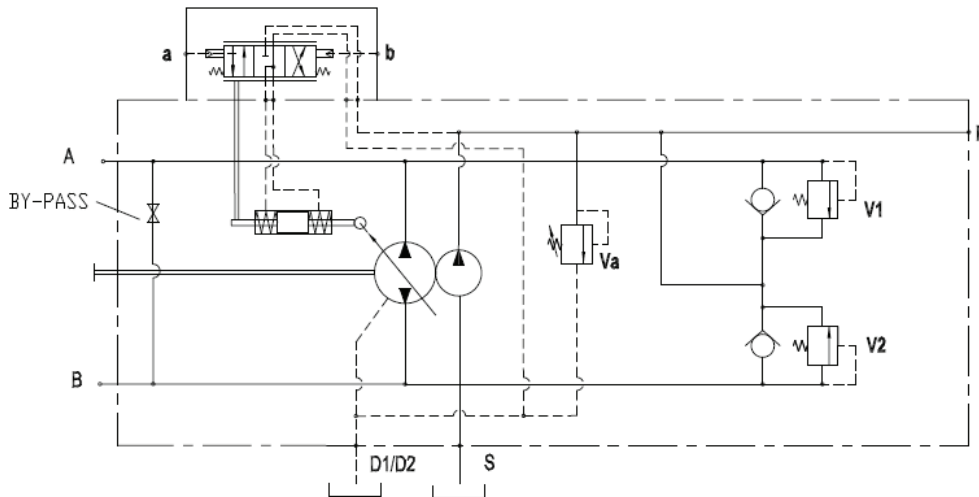

Pilot pressure = 6÷16 bar [87÷232 psi]
(at ports a,b)

Start of control = 6 bar [87 psi]

End of control = 16 bar [232 psi]
(Maximum displacement)

Max pressure = 30 bar [435 psi]

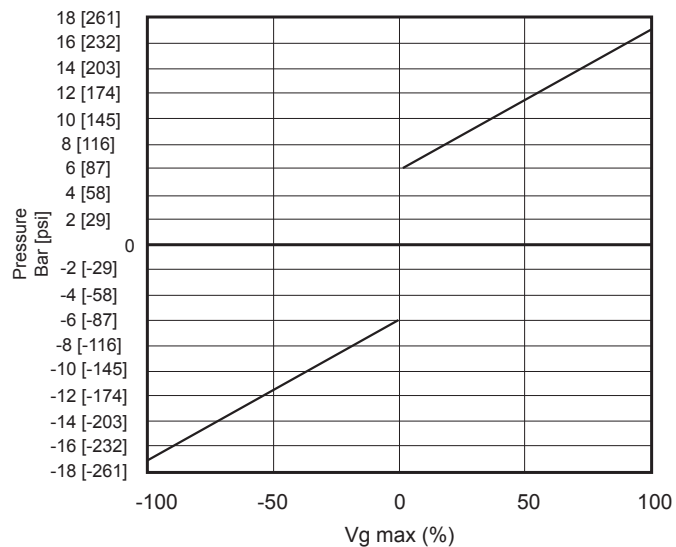

Direction of rotation: Correlation between direction of rotation (shaft view) control and direction of flow.

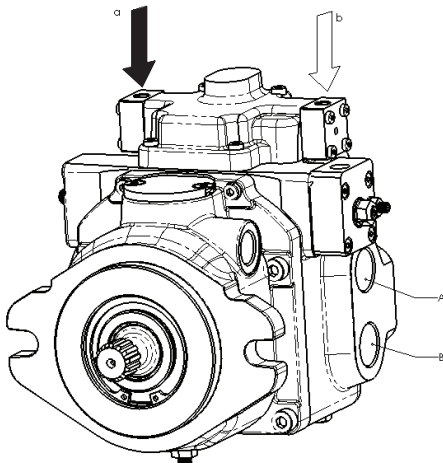

SHAFT ROTATION	PUMP FLOW DIRECTION	
	Piloting Pressure	Pressure Port
(L)	a	B
	b	A
(R)	a	A
	b	B

C2 21/28 Series



Axial Piston Pumps Variable Displacement

PUMP AND CONTROLS DIMENSION - IRX

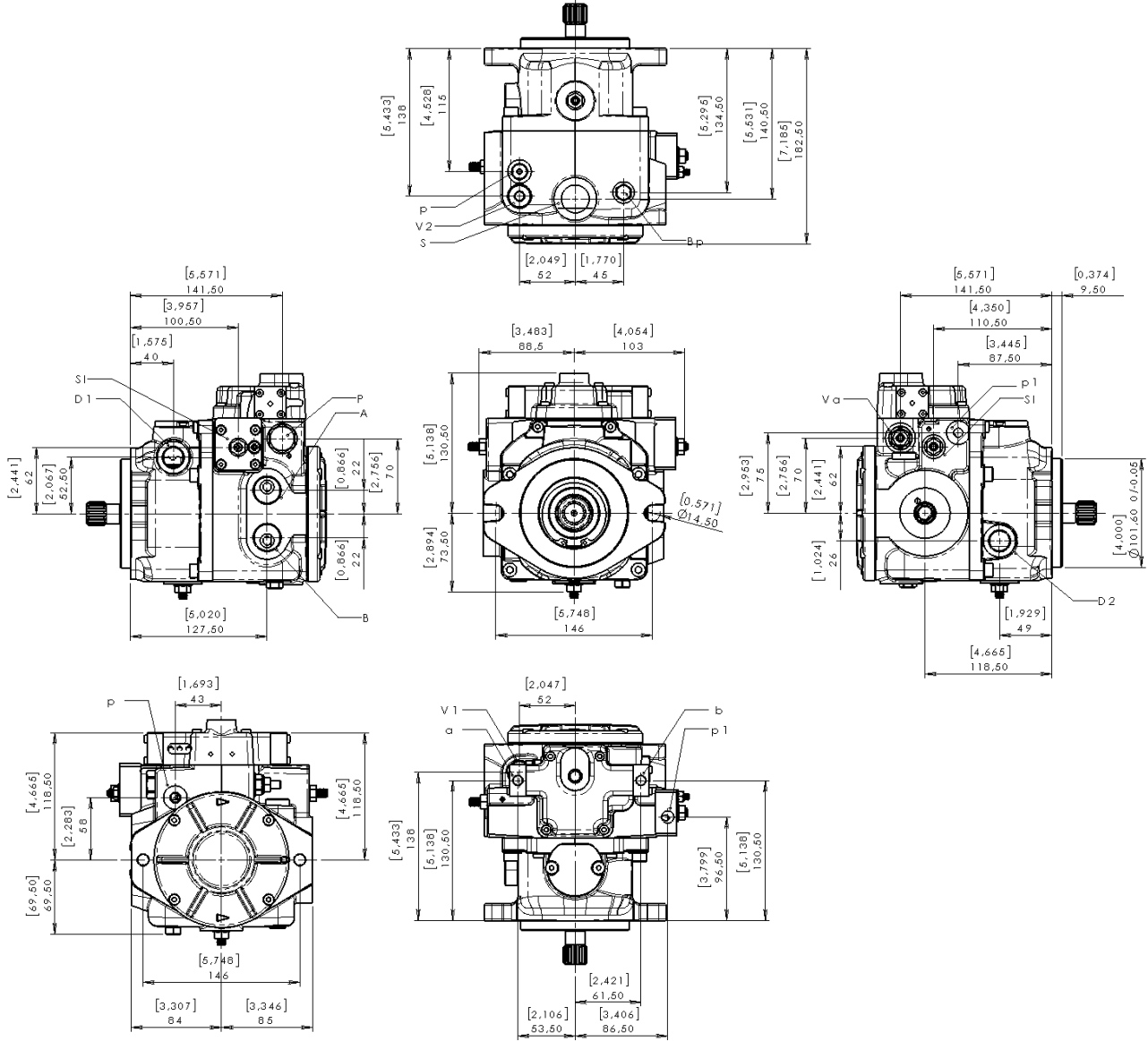

METRIC Version

- A - B: Pressure ports - 3/4 G
- D1 - D2: Drain port - 1/2 G
- S: Suction port - 3/4 G
- P: Charge pressure port - 3/4-16 UNF-2B -> 1/4 G
- Va: Charge pump valve
- V1 - V2: Maximum pressure valves
- Sl: Stroke limiter
- Zm: Mechanical zero adjustment screw
- a - b: Control piloting pressure port - 1/8 G
- p: Ports - 1/8 G
- p1: Ports - 1/4 G

SAE Version

- A - B: Pressure ports - 7/8-14 UNF-2B
- D1 - D2: Drain port - 3/4-16 UNF-2B
- S: Suction port - 1 1/16 UNF-2B
- P: Charge pressure port - 3/4-16 UNF-2B -> 7/16-20 UNF-2B
- Va: Charge pump valve
- V1 - V2: / Maximum pressure valves
- Sl: Stroke limiter
- Zm: Mechanical zero adjustment screw
- a - b: Control piloting pressure port - 3/8-24 UNF-2B
- p: Ports - 3/8-24 UNF-2B
- p1: Ports - 7/16-20 UNF-2B

C2 21/28 Series

Axial Piston Pumps Variable Displacement



MANUAL LEVER WITH FEED-BACK CONTROL - LRX

The displacement of the pump is directly proportional to the angle of the lever. The diagram below shows the relationship between angle and displacement.

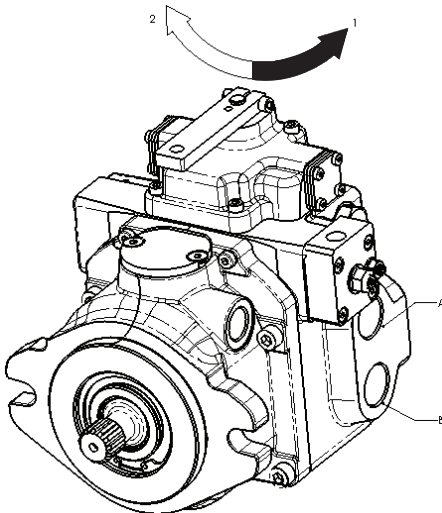
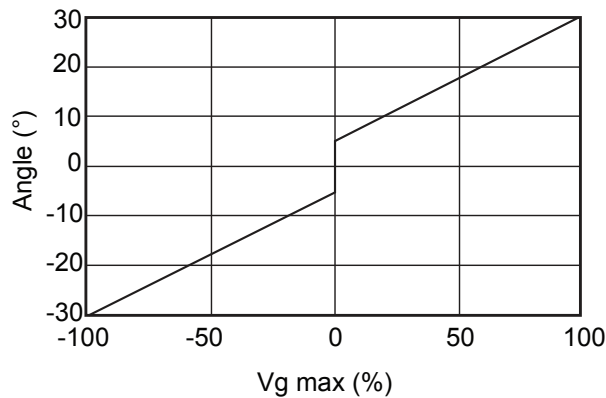
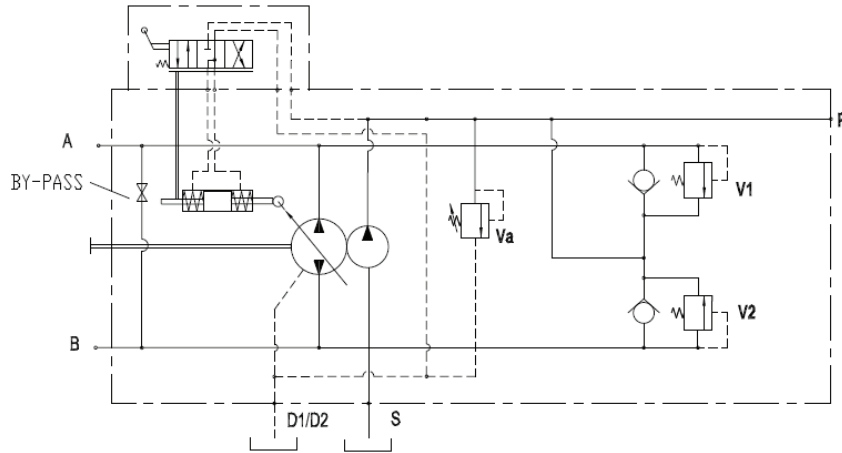

Direction of rotation: Correlation between direction of rotation (shaft view) control and direction of flow.

SHAFT ROTATION	PUMP FLOW DIRECTION	
	Control Rotation	Pressure Port
(L)	1	A
	2	B
(R)	1	B
	2	A

C2 21/28 Series



Axial Piston Pumps Variable Displacement

PUMP AND CONTROLS DIMENSION - LRX

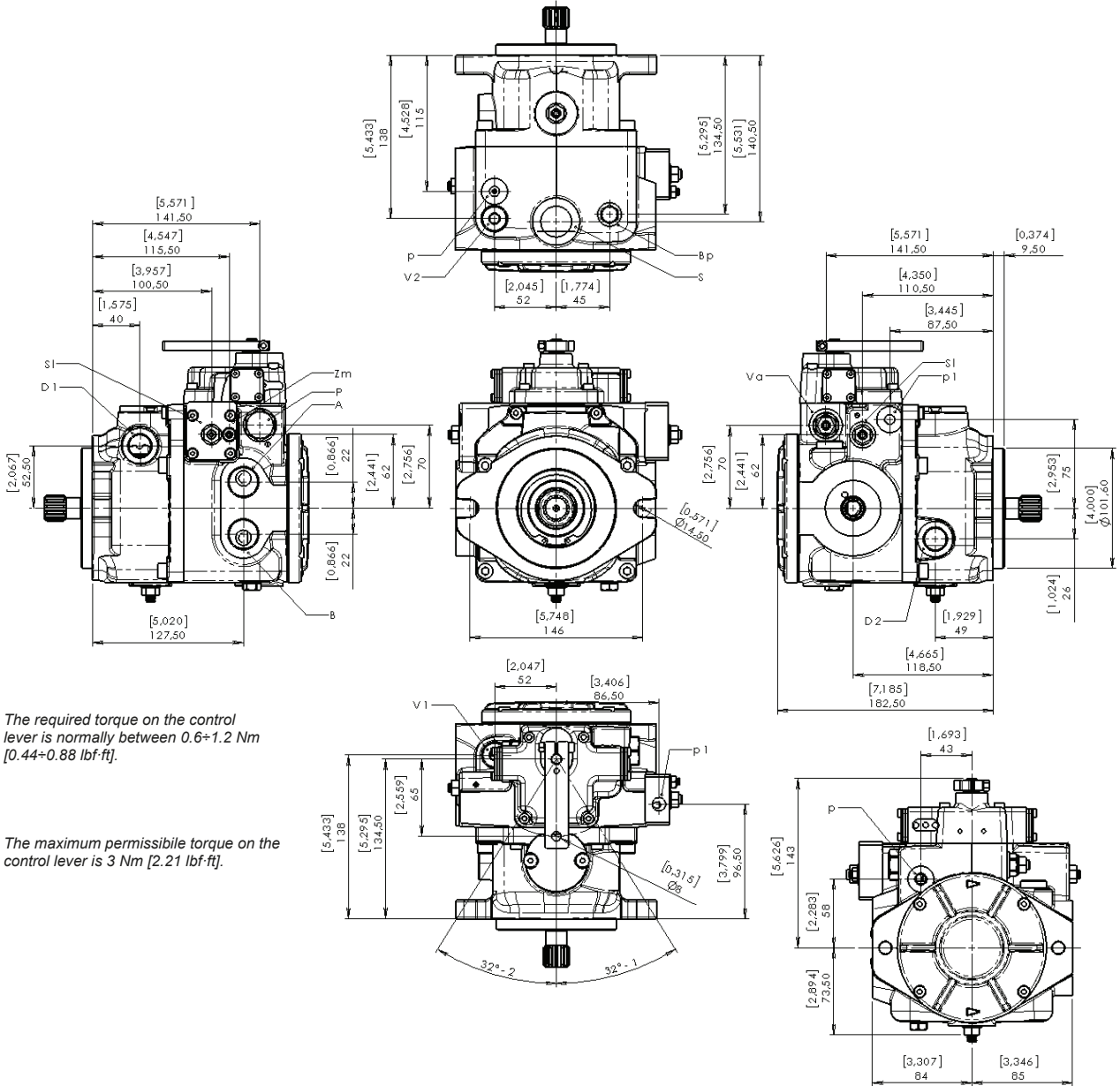

The required torque on the control lever is normally between 0.6÷1.2 Nm [0.44÷0.88 lbf-ft].

The maximum permissible torque on the control lever is 3 Nm [2.21 lbf-ft].

METRIC Version

- A - B: Pressure ports - 3/4 G
- D1 - D2: Drain port - 1/2 G
- S: Suction port - 3/4 G
- P: Charge pressure port - 3/4-16 UNF-2B -> 1/4 G
- Va: Charge pump valve
- V1 - V2: Maximum pressure valves
- Sl: Stroke limiter
- Zm: Mechanical zero adjustment screw
- a - b: Control piloting pressure port - 1/8 G
- p: Ports - 1/8 G
- p1: Ports - 1/4 G

SAE Version

- A - B: Pressure ports - 7/8-14 UNF-2B
- D1 - D2: Drain port - 3/4-16 UNF-2B
- S: Suction port - 1 1/16 UNF-2B
- P: Charge pressure port - 3/4-16 UNF-2B -> 7/16-20 UNF-2B
- Va: Charge pump valve
- V1 - V2: Maximum pressure valves
- Sl: Stroke limiter
- Zm: Mechanical zero adjustment screw
- a - b: Control piloting pressure port - 3/8-24 UNF-2B
- p: Ports - 3/8-24 UNF-2B
- p1: Ports - 7/16-20 UNF-2B

C2 21/28 Series

Axial Piston Pumps Variable Displacement



MANUAL WITH ZEROING CONTROL - LNX

The pump displacement variation of the pump is achieved by rotating the control pivot (i.e. by the means of a lever - not supplied). The control pivot is built into the swash plate of the pump. The return to zero displacement of the pump is guaranteed by an internal spring.

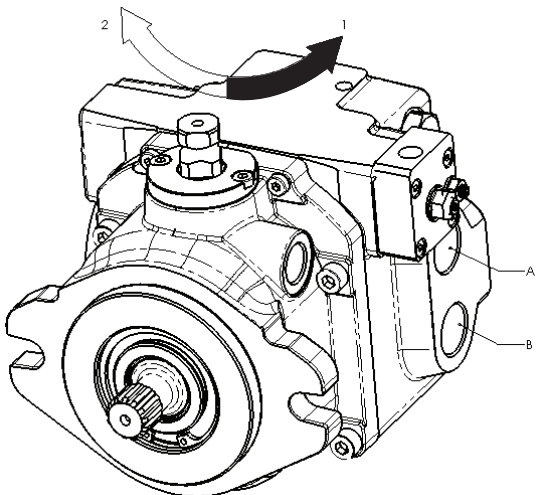
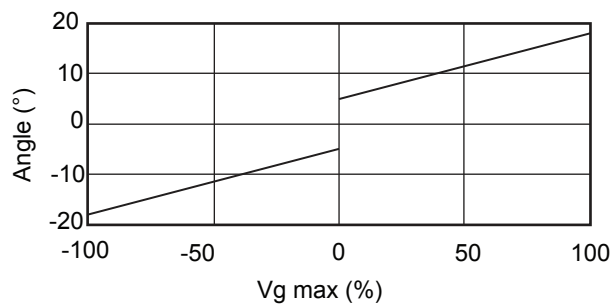
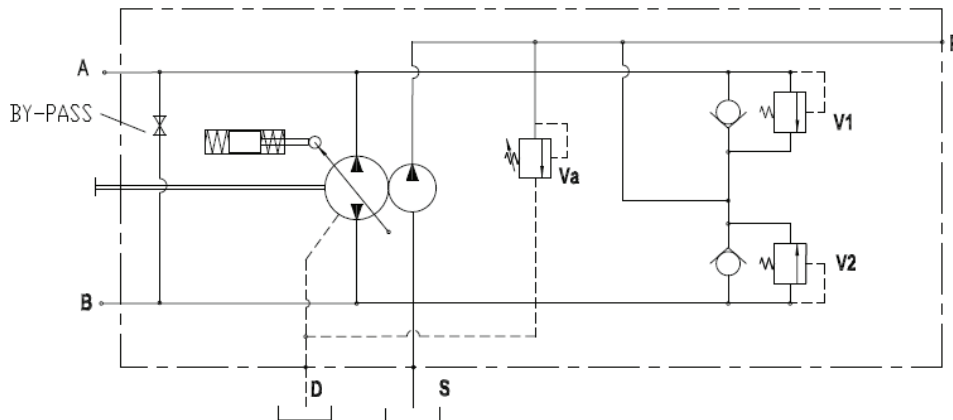

Direction of rotation: Correlation between direction of rotation (shaft view) control and direction of flow.

SHAFT ROTATION	PUMP FLOW DIRECTION	
	Control Rotation	Pressure Port
(L)	1	B
	2	A
(R)	1	A
	2	B

C2 21/28 Series



Axial Piston Pumps Variable Displacement

PUMP AND CONTROLS DIMENSION - LNX

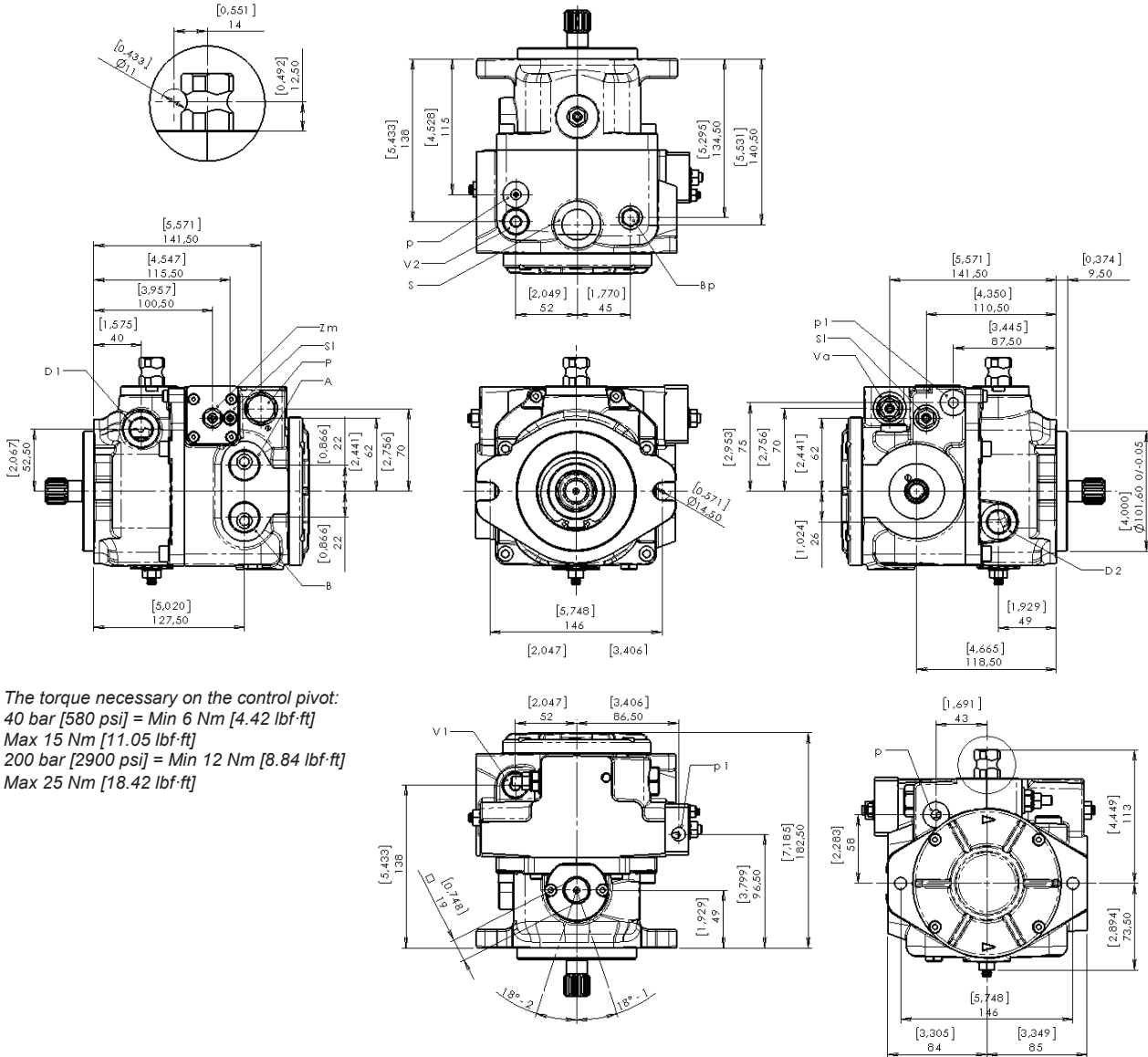

The torque necessary on the control pivot:
 40 bar [580 psi] = Min 6 Nm [4.42 lbf-ft]
 Max 15 Nm [11.05 lbf-ft]
 200 bar [2900 psi] = Min 12 Nm [8.84 lbf-ft]
 Max 25 Nm [18.42 lbf-ft]

METRIC Version

A - B: Pressure ports - 3/4 G
 D1 - D2: Drain port - 1/2 G
 S: Suction port - 3/4 G
 P: Charge pressure port - 3/4-16 UNF-2B -> 1/4 G
 Va: Charge pump valve
 V1 - V2: Maximum pressure valves
 Sl: Stroke limiter
 Zm: Mechanical zero adjustment screw
 a - b: Control piloting pressure port - 1/8 G
 p: Ports - 1/8 G
 p1: Ports - 1/4 G

SAE Version

A - B: Pressure ports - 7/8-14 UNF-2B
 D1 - D2: Drain port - 3/4-16 UNF-2B
 S: Suction port - 1 1/16 UNF-2B
 P: Charge pressure port - 3/4-16 UNF-2B -> 7/16-20 UNF-2B
 Va: Charge pump valve
 V1 - V2: Maximum pressure valves
 Sl: Stroke limiter
 Zm: Mechanical zero adjustment screw
 a - b: Control piloting pressure port - 3/8-24 UNF-2B
 p: Ports - 3/8-24 UNF-2B
 p1: Ports - 7/16-20 UNF-2B

C2 21/28 Series

Axial Piston Pumps Variable Displacement



ELECTRIC TWO POSITION ON-OFF - E22/E24

By switching on one of the ON-OFF solenoids (standard 24V d.c. optional 12V d.c.), the pump swivels to maximum displacement in the corresponding output flow direction. Switching off the stated solenoid will result in swivelling back the pump to zero displacement position.

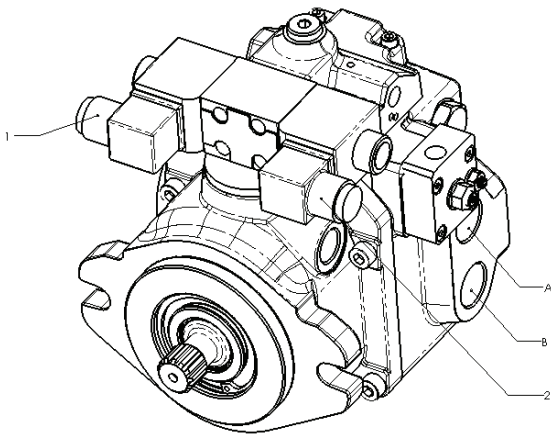
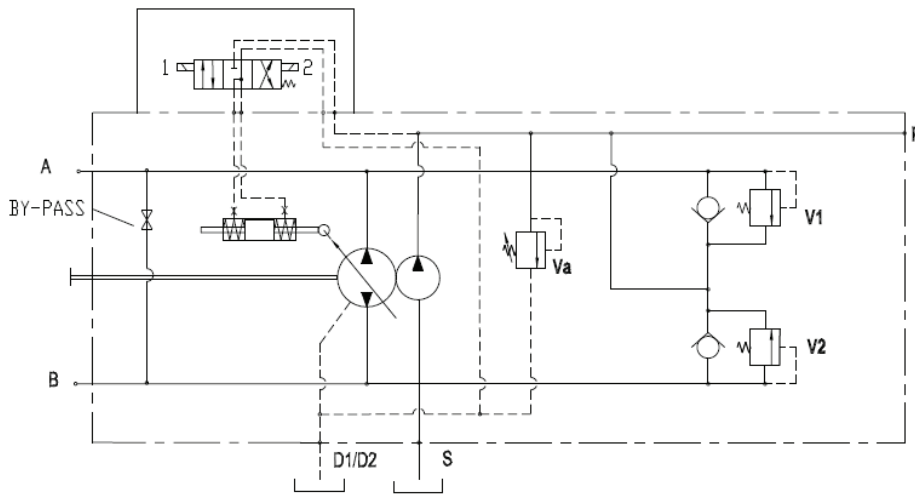

Direction of rotation: Correlation between direction of rotation (shaft view) control and direction of flow.

SHAFT ROTATION	PUMP FLOW DIRECTION	
	Energised Solenoid	Oil Outlet
(L)	1	B
	2	A
(R)	1	A
	2	B

C2 21/28 Series

Axial Piston Pumps Variable Displacement



ELECTRIC PROPORTIONAL WITH FEED-BACK CONTROL - ER2/ER4

The displacement of the pump is directly proportional to the input current of one of the two proportional solenoids. Flow direction depends on which solenoid is energised. Standard solenoids are proportional at 24V d.c. max. current 1A. (Optional solenoids 12V d.c. max. current 2A).

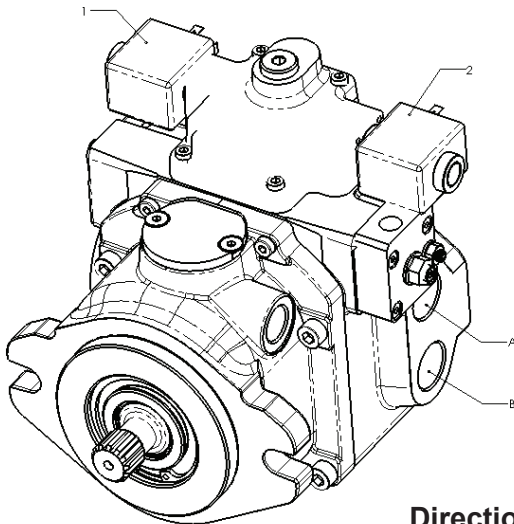
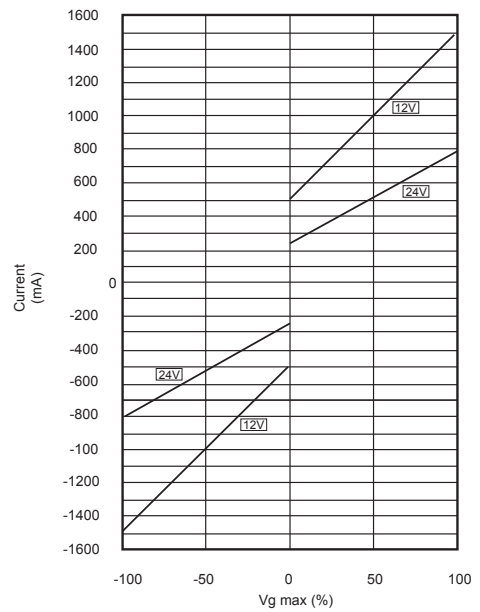
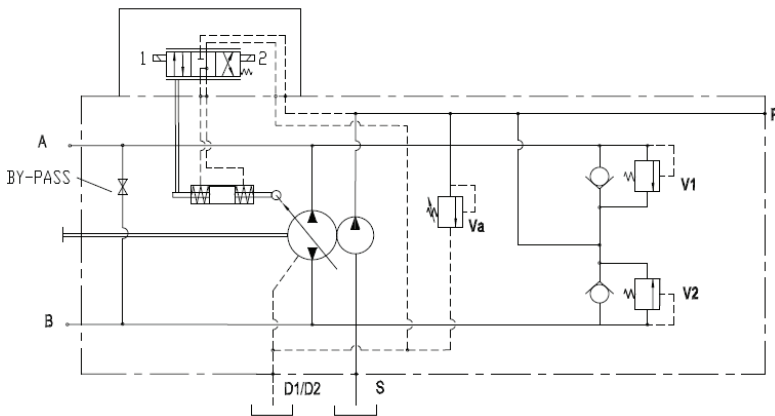

Solenoid 24V:
Current min. 240 mA max. 800 mA

Solenoid 12V:
Current min. 500 mA max. 1500 mA

Direction of rotation: Correlation between direction of rotation (shaft view) control and direction of flow.

SHAFT ROTATION	PUMP FLOW DIRECTION	
	Energised Solenoid	Oil Outlet
(L)	1	B
	2	A
(R)	1	A
	2	B

C2 21/28 Series

Axial Piston Pumps Variable Displacement



PUMP AND CONTROLS DIMENSION - ER2/ER4

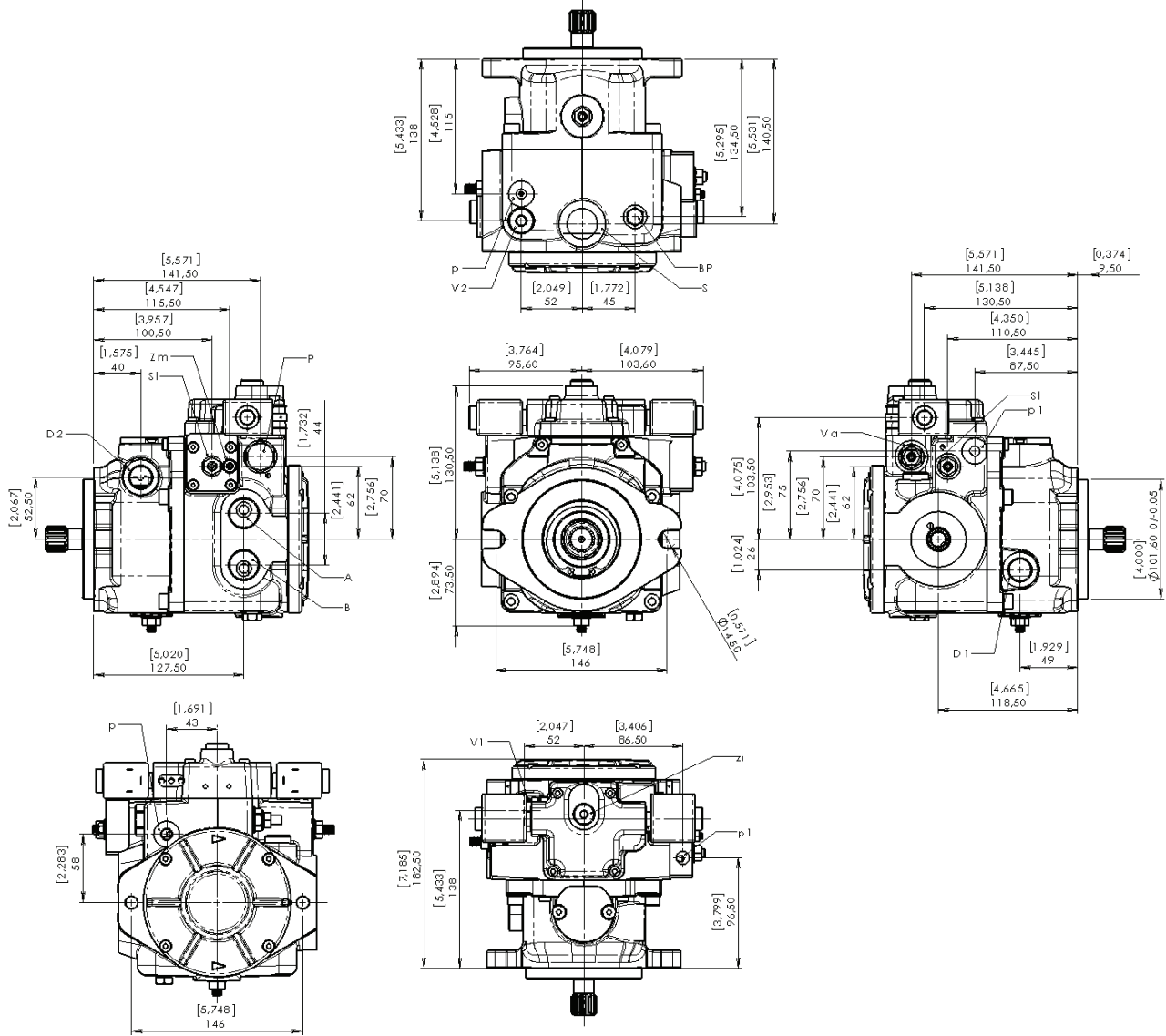

METRIC Version

- A – B: Pressure ports – 3/4 G
- D1 – Drain port – 1/2 G
- S: Suction port – 3/4 G
- P: Charge pressure port – 3/4-16 UNF-2B -> 1/4 G
- Va: Charge pump valve
- V1 – V2: Maximum pressure valves
- Sl: Stroke limiter
- Zm: Mechanical zero adjustment screw
- a – b: Control piloting pressure port – 1/8 G
- p: Ports – 1/8 G
- p1: Ports – 1/4 G
- Zi: Hydraulic zero

SAE Version

- A – B: Pressure ports – 7/8-14 UNF-2B
- D1 – Drain port – 3/4-16 UNF-2B
- S: Suction port – 1 1/16 UNF-2B
- P: Charge pressure port – 3/4-16 UNF-2B -> 7/16-20 UNF-2B
- Va: Charge pump valve
- V1 – V2: Maximum pressure valves
- Sl: Stroke limiter
- Zm: Mechanical zero adjustment screw
- a – b: Control piloting pressure port – 3/8-24 UNF-2B
- p: Ports – 3/8-24 UNF-2B
- p1: Ports – 7/16-20 UNF-2B
- Zi: Hydraulic zero

C2 21/28 Series

Axial Piston Pumps Variable Displacement



ELECTRIC PROPORTIONAL WITHOUT FEED-BACK CONTROL - EP2/EP4

The displacement of the pump is directly proportional to the input current of one of the two proportional solenoids. Flow is also influenced by the working pressure. With a given input signal (piloting current) the pump can slightly vary the displacement and the flow when working pressure increases. The input current of the two proportional solenoids must be controlled by an external amplifier card. Flow direction depends on which solenoid is energised. Standard solenoids are proportional 24V d.c. max. current 1A. (Optional solenoids 12V d.c. max. current 2A). For emergency operation only it is however possible to control solenoids directly with 24V d.c. voltage (or 12V d.c.), by-passing the amplifier.

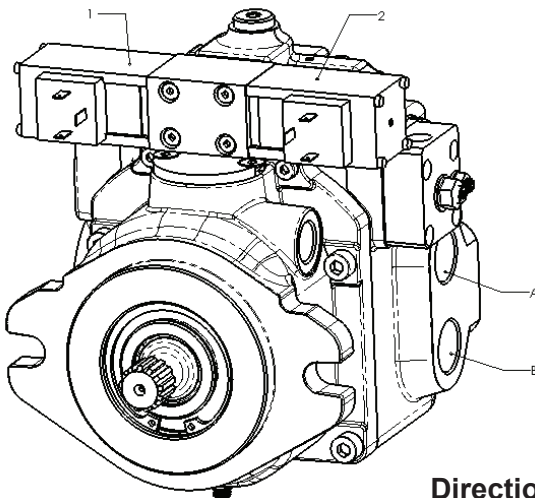
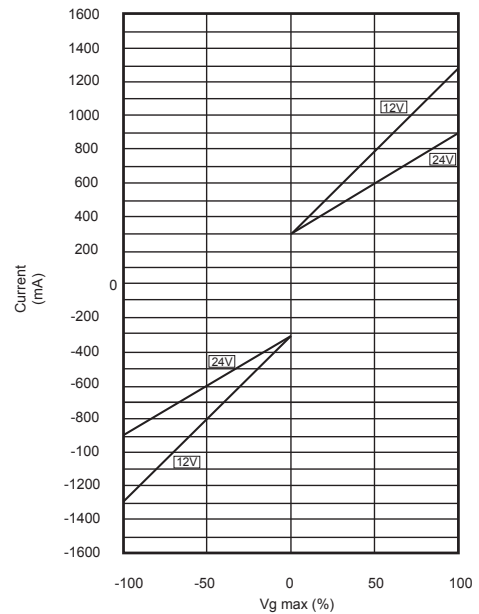
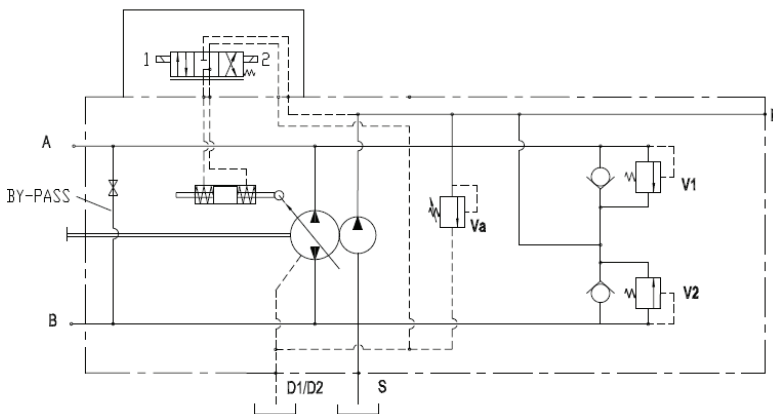

Solenoid 24V:
Current min. 300 mA max. 900 mA

Solenoid 12V:
Current min. 300 mA max. 1300 mA

Direction of rotation: Correlation between direction of rotation (shaft view) control and direction of flow.

SHAFT ROTATION	PUMP FLOW DIRECTION	
	Energised Solenoid	Oil Outlet
(L)	1	B
	2	A
(R)	1	A
	2	B

C2 21/28 Series

Axial Piston Pumps Variable Displacement



PUMP AND CONTROLS DIMENSION - EP2/EP4

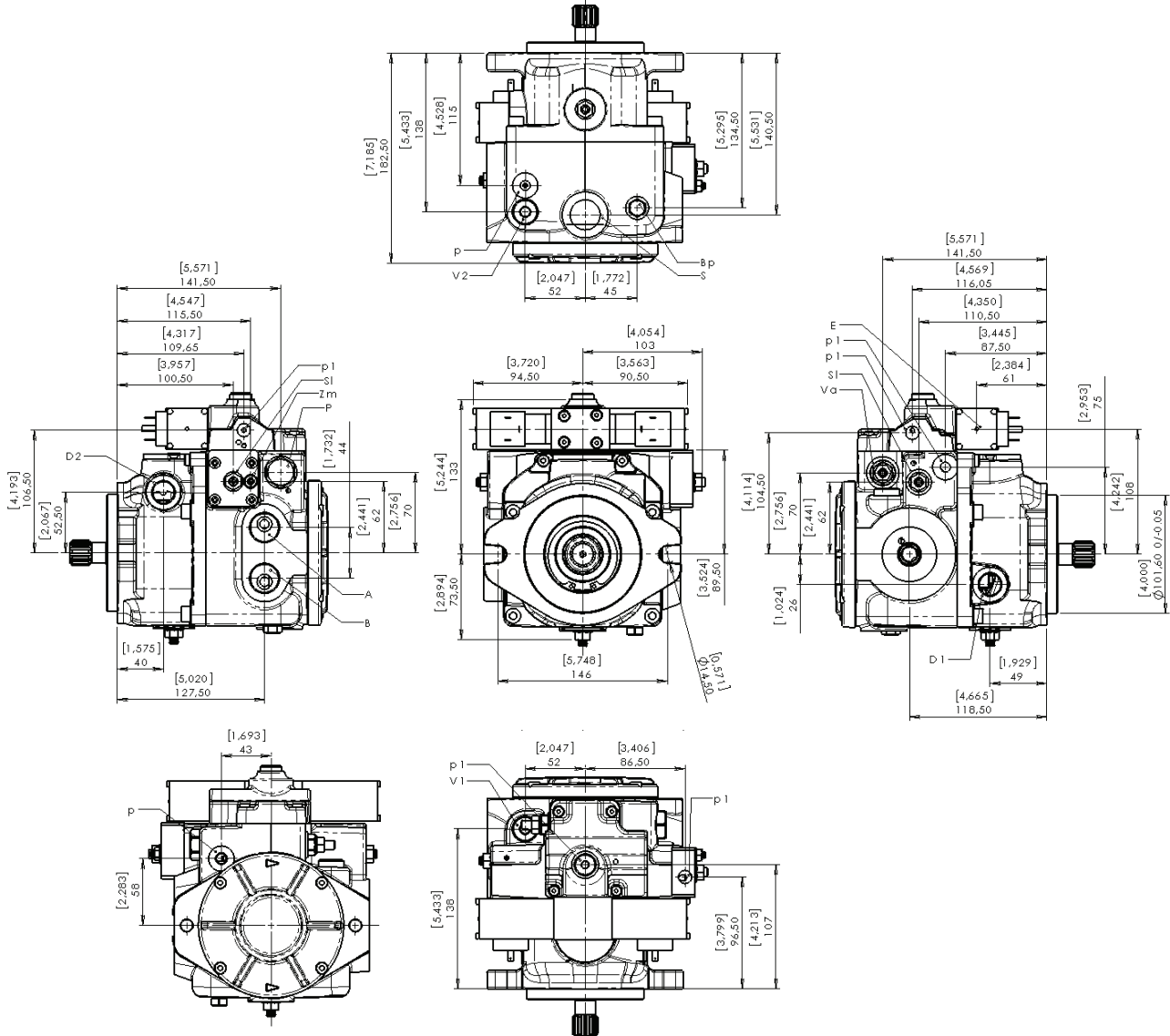

METRIC Version

- A – B: Pressure ports – 3/4 G
- D1 – D2: Drain port – 1/2 G
- S: Suction port – 3/4 G
- P: Charge pressure port – 3/16 UNF-2B -> 1/4 G
- Va: Charge pump valve
- V1 – V2: Maximum pressure valves
- Sl: Stroke limiter
- Zm: Mechanical zero adjustment screw
- a – b: Control piloting pressure port – 1/8 G
- p: Ports – 1/8 G
- p1: Ports – 1/4 G
- E: Hand emergency

SAE Version

- A – B: Pressure ports – 7/8-14 UNF-2B
- D1 – D2: Drain port – 3/4-16 UNF-2B
- S: Suction port – 1 1/16 UNF-2B
- P: Charge pressure port – 3/4-16 UNF-2B -> 7/16-20 UNF-2B
- Va: Charge pump valve
- V1 – V2: Maximum pressure valves
- Sl: Stroke limiter
- Zm: Mechanical zero adjustment screw
- a – b: Control piloting pressure port – 3/8-24 UNF-2B
- p: Ports – 3/8-24 UNF-2B
- p1: Ports – 7/16-20 UNF-2B
- E: Hand emergency

C2 21/28 Series

Axial Piston Pumps Variable Displacement



THROUGH DRIVES DIMENSION

SPLINE SHAFT

Type 1 - S T13

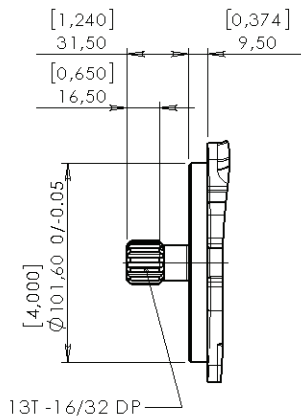

Type 2 - S T15

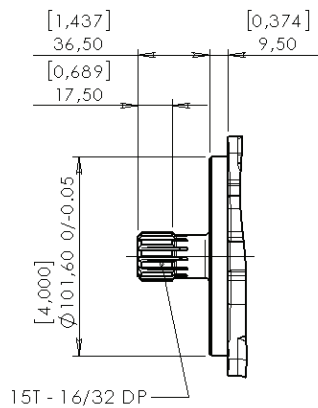

Type 3 - S T13

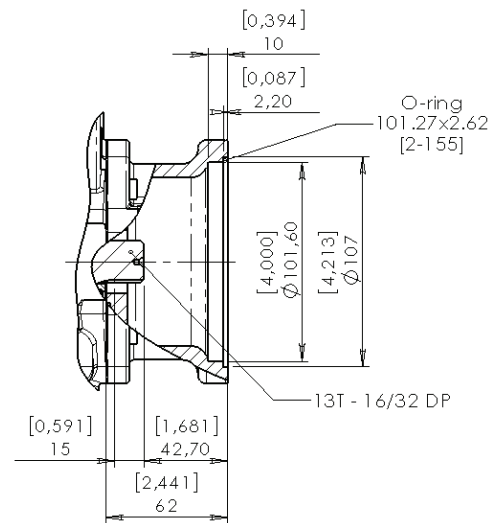

Type 4 - IS T13

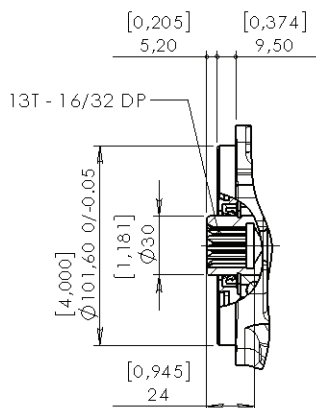

Type 5 - IS T9

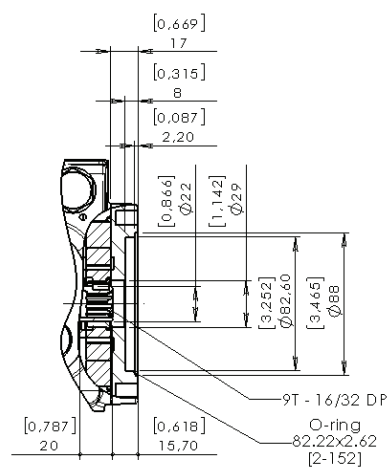

Type 6 - S T11

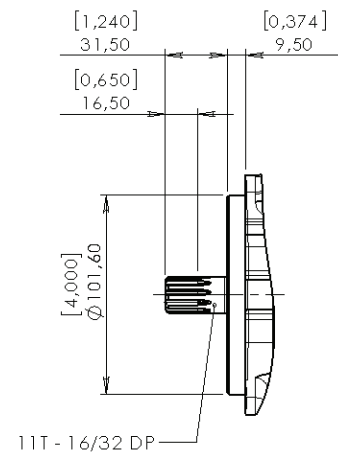

C2 21/28 Series



Axial Piston Pumps Variable Displacement

BOOSTER PUMP FILTER ON DELIVERY SIDE

In order to guarantee an optimum stability of the fluid contamination conditions the “C” Series can be equipped with a filter positioned on the delivery outlet of the booster pump. Only the flow necessary to reintegrate the lost oil due to drainage will pass through this filter, all the excess flow, which is drained by the booster pump valve, is therefore not filtered, in this way it will guarantee a longer life of the filter. Upon request it is possible to add an electrical filter clogging sensor. (Connector DIN 43650A).

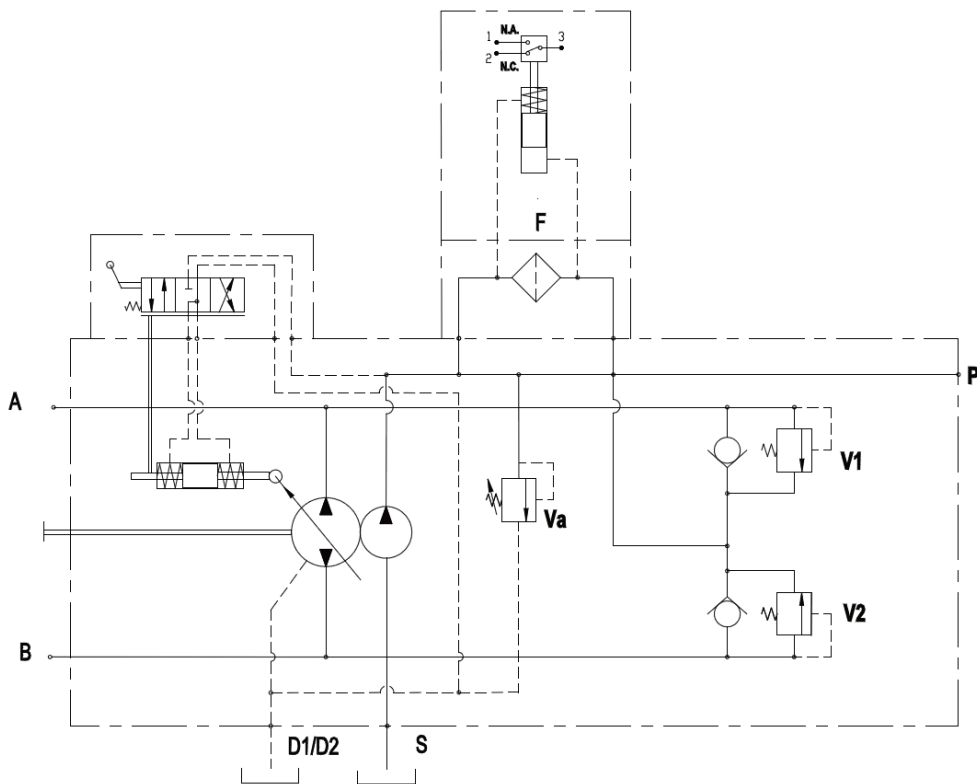

Electrical Sensor

SPDT	Max Resistive Load	Max Inductive Load
C.A.\A.C. 125-250 V	1 A	1 A
C.C.\D.C. 30 V	2A	2A
C.C.\D.C. 50 V	0.5 A	0.5 A
C.C.\D.C. 75 V	0.25 A	0.25A
C.C.\D.C. 125 V	0.2 A	0.2 A

C2 21/28 Series

Axial Piston Pumps Variable Displacement



ACCESSORIES AND FILTER DIMENSIONS

Filter FE

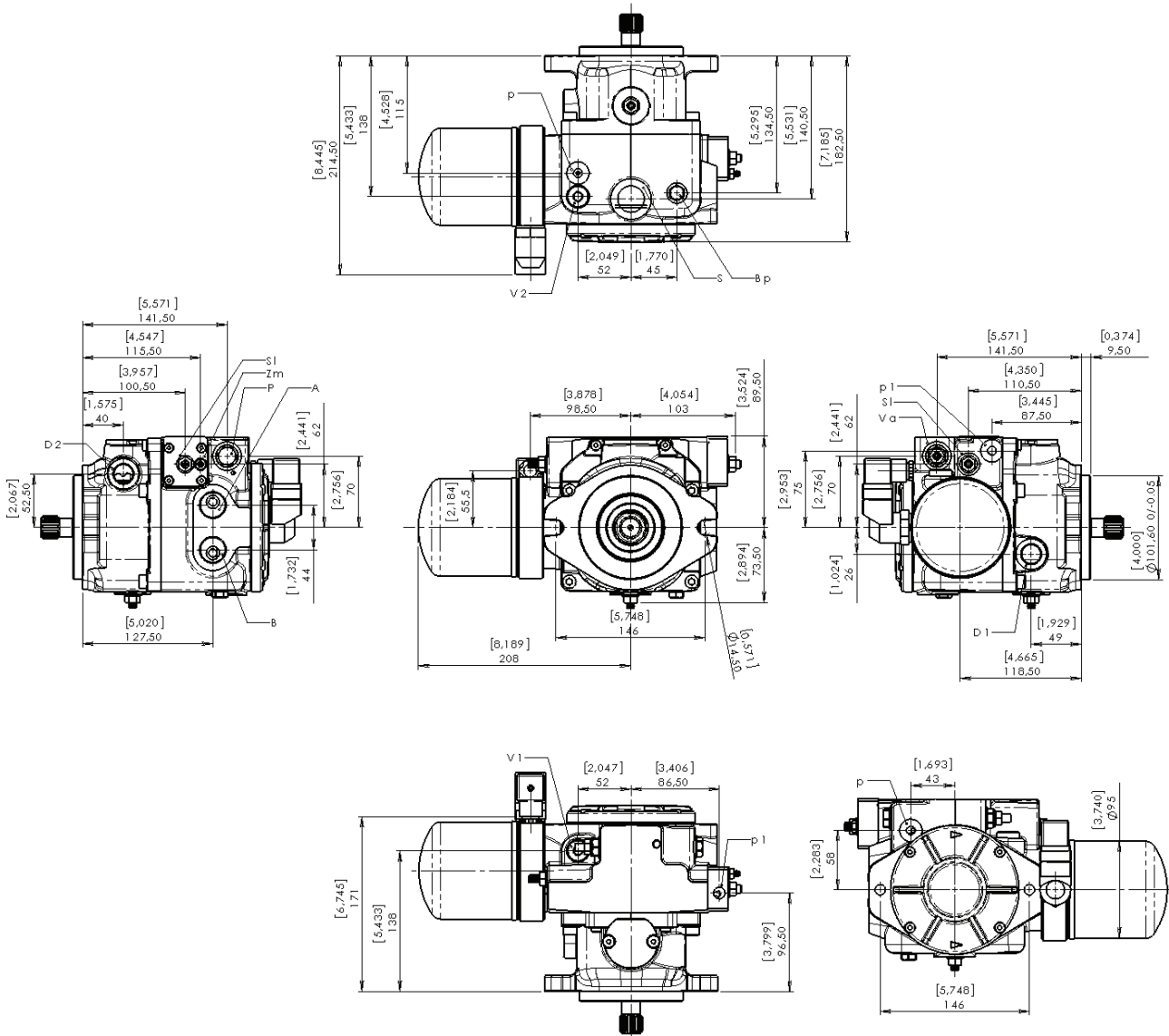

C2 21/28 Series

Axial Piston Pumps Variable Displacement



ACCESSORIES AND FILTER DIMENSIONS

Filter

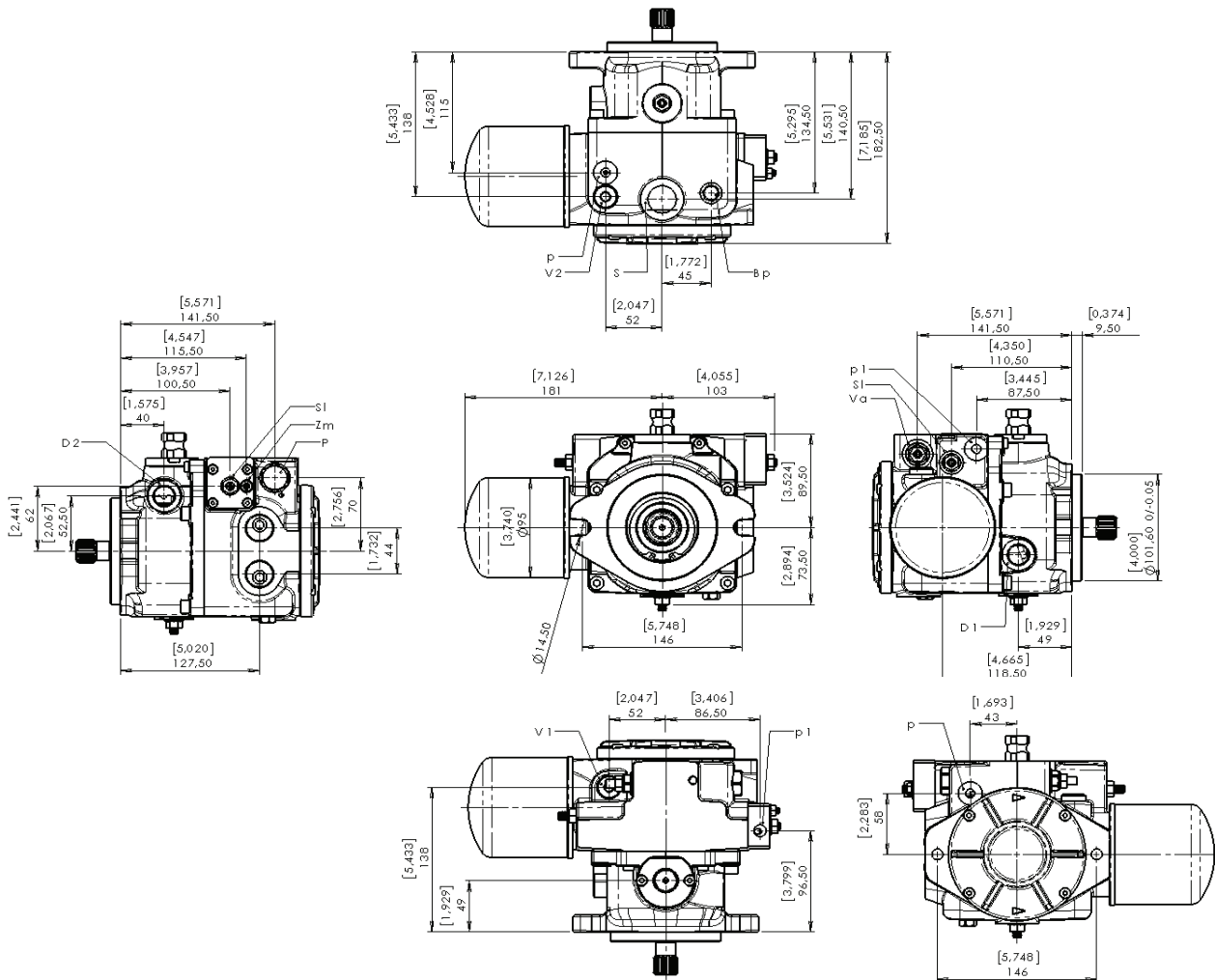
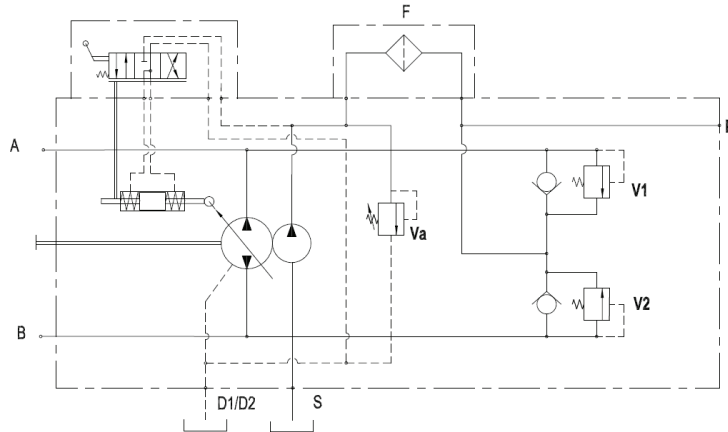

C2 21/28 Series

Axial Piston Pumps Variable Displacement



ACCESSORIES

Exchange Valve

The flushing valve allows a cooling action, which is recommended when operating at high speed and power.

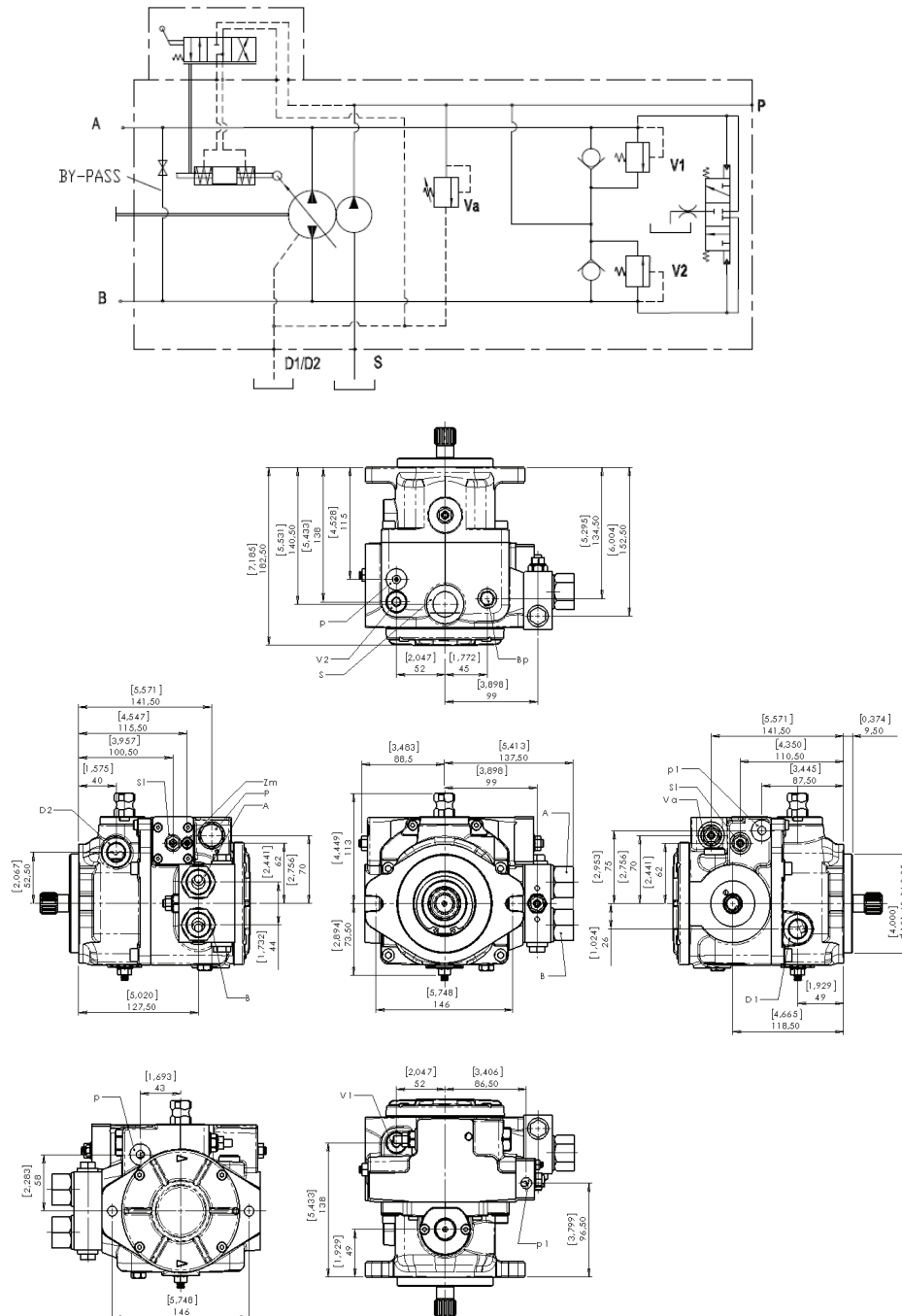

C2 21/28 Series

Axial Piston Pumps Variable Displacement



ACCESSORIES

Electric Cut-Off Valve

The electric cut-off valve, brings to zero the displacement of the pump when power supply to the ON/OFF solenoid is cut-off. Feed voltage is 12V d.c. or 24V d.c. The cut-off valve cannot be assembled in the Tandem pump short version.

CONNECTOR = DIN43650A

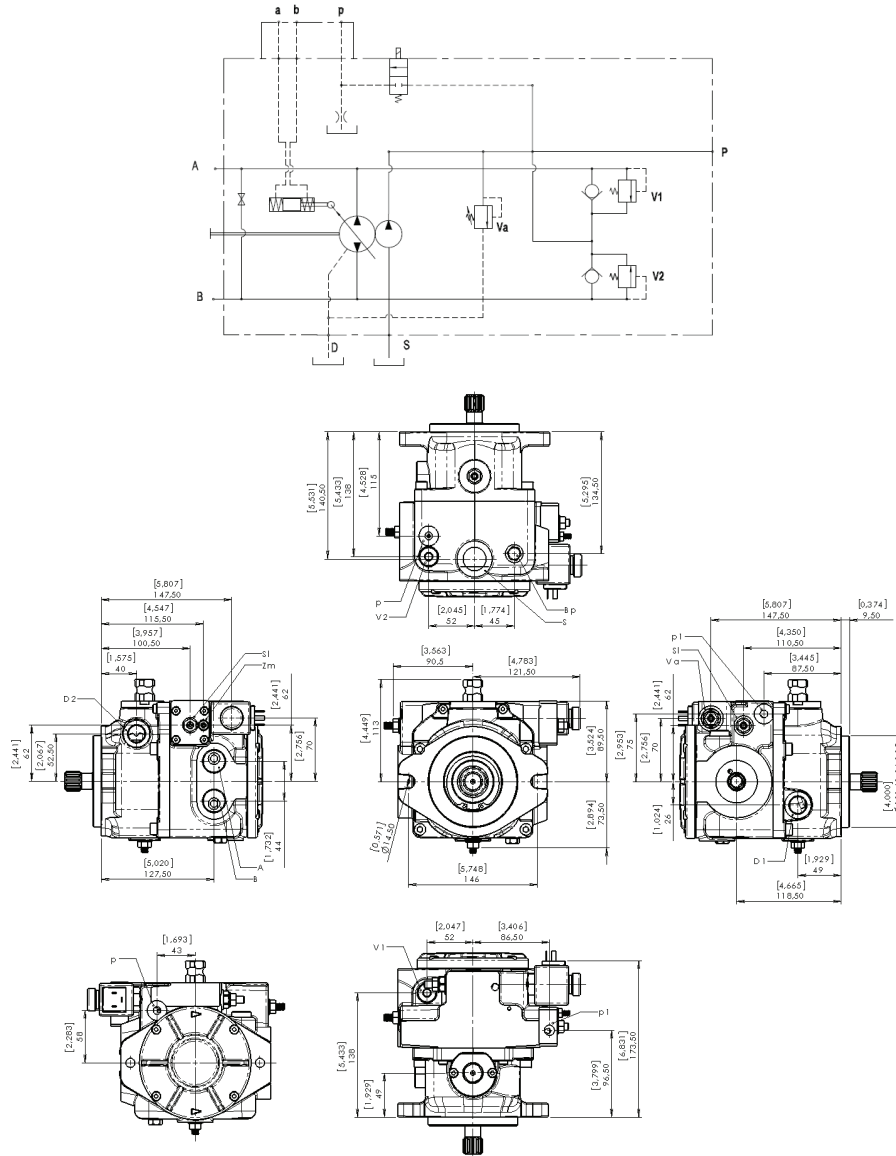

C2 21/28 Series

Axial Piston Pumps Variable Displacement



COMBINATION PUMP DIMENSIONS - SHORT VERSION

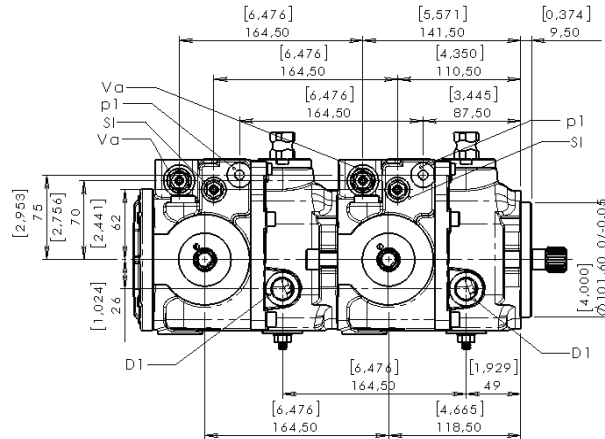

Configuration	C2 21/28 + C2 21/28	
Pump	1st	2nd
Shafts	2	4

With this configuration, only the second pump mount the boost pump.

Warning: When ordering a tandem pump it is necessary to indicate for each pump the kind of shaft and the through drive option required.

Short Version Tandem (TS) Hydraulic Layout

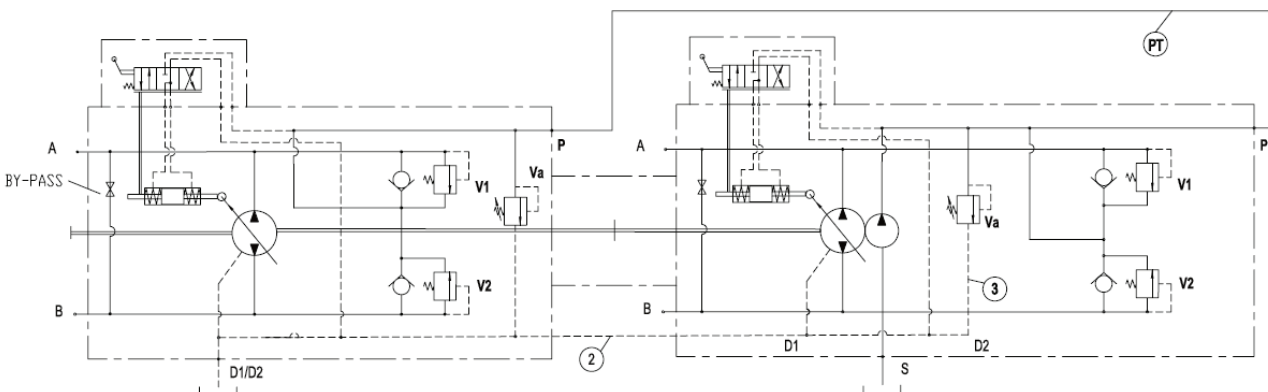

The hose (1) used to connect the charge pressure ports (P) is supplied with the units. The hoses (2) and (3) connecting the drain ports must be supplied and mounted by the customer.

C2 21/28 Series

Axial Piston Pumps Variable Displacement



COMBINATION PUMP DIMENSIONS - LONG VERSION

Tandem C2 21/28 + C2 21/28 SAE-B

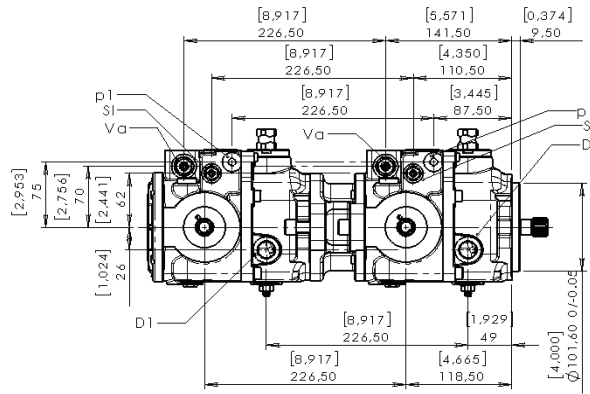

Shafts for combination pumps

Configuration	C2 21/28 + C2 21/28	
Pump	1st	2nd
Shafts	3 ⁽¹⁾	1 ⁽²⁾

With this configuration, both the pumps mount the boost pump.

- (1) It is necessary to mount on the first pump the through drive - SAE B
- (2) 1 - Spline Shaft 13T - 16/32-DP (C2 21/28)

Tandem C2 21/28 + C1 14/18

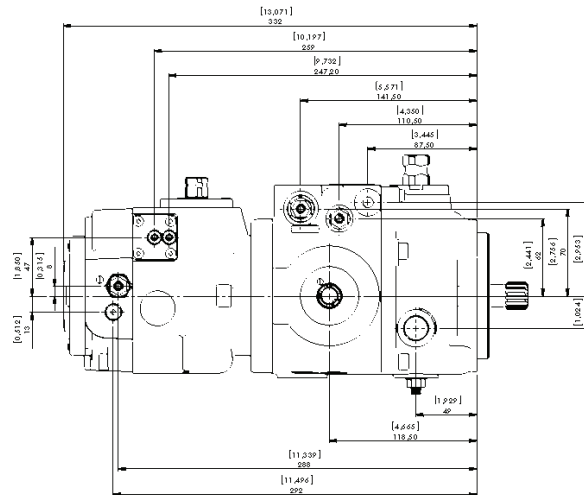

Shafts for combination pumps

Configuration	C2 21/28 + C1 14/18	
Pump	1st	2nd
Shafts	1 (C2 21/28) ⁽¹⁾	1 o 2 (C1 14/18) ⁽²⁾

With this configuration, both the pumps mount the boost pump.

- (1) It is necessary to mount on the first pump the through drive - SAE A
- (2) 01 - Spline Shaft 9T - 16/32-DP (C1 14/18)
- 02 - Spline Shaft 9T - 16/32-DP (Through drive Bosch) (C1 14/18)

C2 21/28 Series

Axial Piston Pumps Variable Displacement



COMBINATION PUMP DIMENSIONS - LONG VERSION

First pump with through drive-**SAE B**

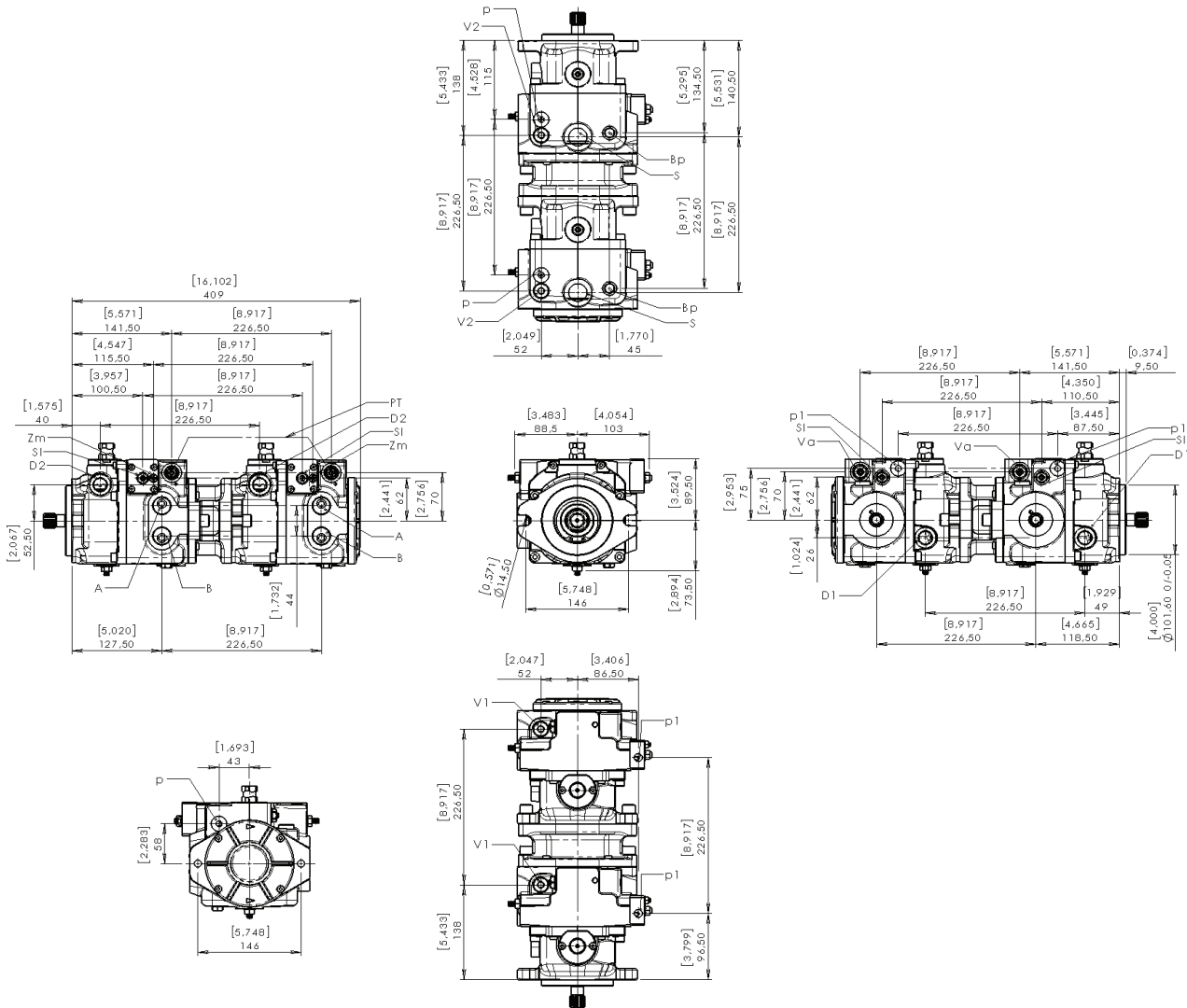

METRIC Version

A - B: Pressure ports - 3/4 G
 D1 - D2: Drain port - 1/2 G
 S: Suction port - 3/4 G
 P: Charge pressure port - 3/4-16 UNF-2B -> 1/4 G
 Va: Charge pump valve
 V1 - V2: Maximum pressure valves
 SI: Stroke limiter
 Zm: Mechanical zero adjustment screw
 a - b: Control piloting pressure port - 1/8 G
 p: Ports - 1/8 G
 p1: Ports - 1/4 G

SAE Version

A - B: Pressure ports - 7/8-14 UNF-2B
 D1 - D2: Drain port - 3/4-16 UNF-2B
 S: Suction port - 1 1/16 UNF-2B
 P: Charge pressure port - 3/4-16 UNF-2B -> 7/16-20 UNF-2B
 Va: Charge pump valve
 V1 - V2: Maximum pressure valves
 SI: Stroke limiter
 Zm: Mechanical zero adjustment screw
 a - b: Control piloting pressure port - 3/8-24 UNF-2B
 p: Ports - 3/8-24 UNF-2B
 p1: Ports - 7/16-20 UNF-2B