

HU-S3E Direct Acting Spool, 3 Way 2 Position, High Pressure

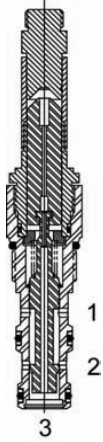

DESCRIPTION

12 size, 1 1/16-12 thread, "Tecnorm" series, solenoid operated, 3 way 2 position, spool valve.

OPERATION

When de-energized the HU-S3E allows flow from (2) to (1) and blocks flow at port (3). When energized the valve allows flow from (3) to (2) and blocks flow at port (1).

FEATURES

- Hardened parts for long life.
- Efficient wet-armature construction.
- Cartridges are voltage interchangeable.
- Industry common cavity.
- Unitized, molded coil design.
- Continuous duty rated solenoid.
- Optional coil voltages and terminations.

HYDRAULIC SYMBOL

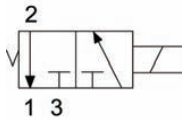

Common usage is inlet at port 3.
See HU-S3F for port 2 or port 1 inlet.

PERFORMANCE

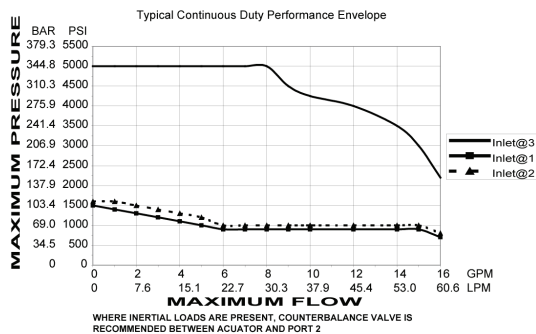
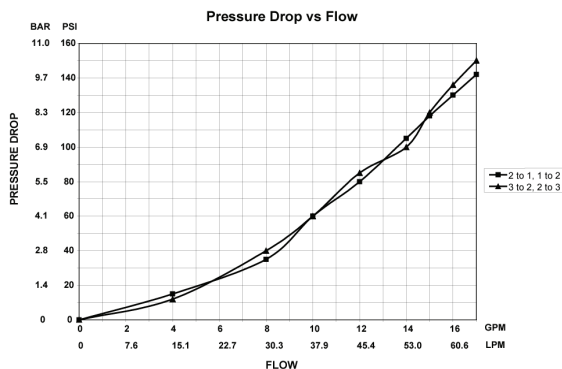

VALVE SPECIFICATIONS

Nominal Flow	15 GPM (57 LPM)
Rated Operating Pressure	5000 PSI (345 bar)
Typical Internal Leakage (150 SSU)	8 cu in/min @ 3000 PSI
Viscosity Range	36 to 3000 SSU (3 to 647 cSt)
Filtration	ISO 18/16/13
Media Operating Temperature Range	-40° to 250° F (-40° to 120° C)
Weight	1.01 lbs. (.46 kg)
Operating Fluid Media	General Purpose Hydraulic Fluid
Cartridge Torque Requirements	70 ft-lbs (94.9 Nm)
Coil Nut Torque Requirements	5-7 ft-lbs (6.8-9.5 Nm)
Cavity	TECNORD 3W
Cavity Form Tool (Finishing)	40500034
Seal Kit	21191305

HUS3E00

Solenoid Operated Directional Controls



DIMENSIONS

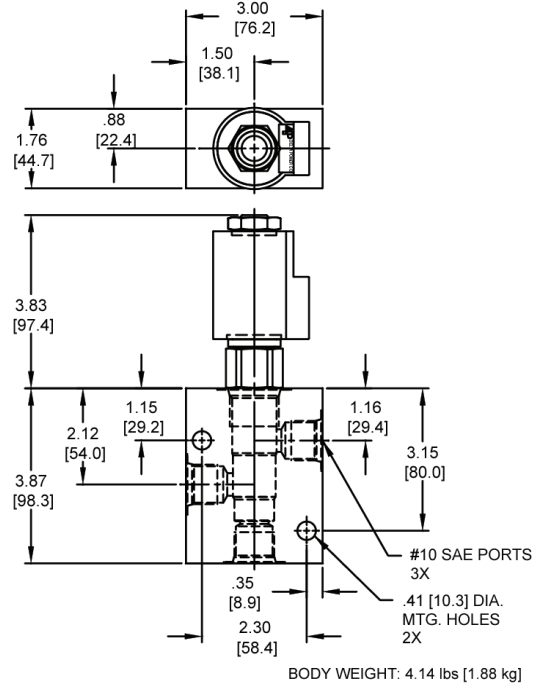
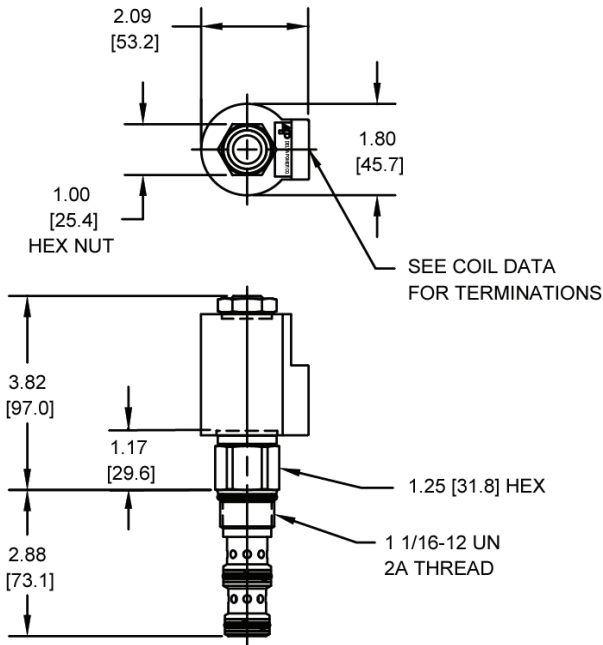

ORDERING INFORMATION

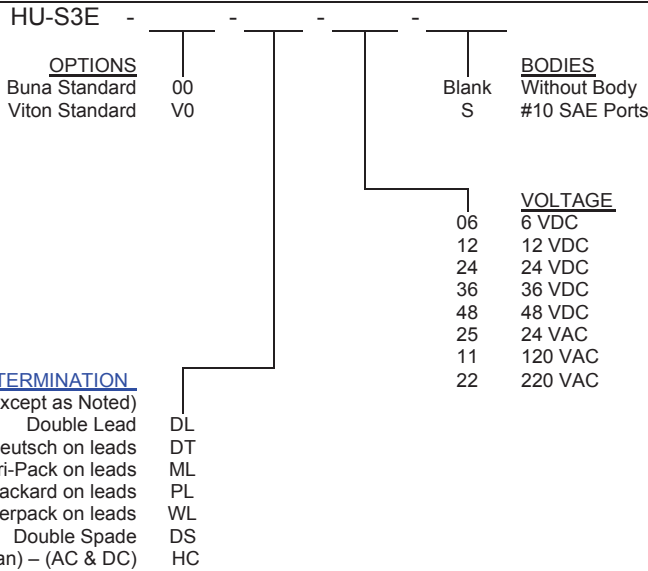

Approximate Coil Weight: .89 lbs/.41 kg.