

PQS4B00

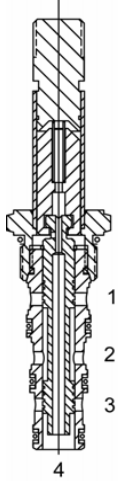

Solenoid Operated Directional Controls

PQ-S4B Direct Acting Spool, 4 Way 2 Position, Closed Center



DESCRIPTION

8 size, 3/4 -16 thread, "Power" series, solenoid operated, 4 way 2 position, closed center spool valve.

OPERATION

When de-energized the PQ-S4B blocks flow at all ports. When energized the valve allows flow from (2) to (1) and from (3) to (4).

OPERATION OF MANUAL OVERRIDE OPTION: To override, pull knob out. On the detented version, after pulling knob out twist 180 degrees and release. The valve will remain in that position.

FEATURES

- Hardened parts for long life.
- Efficient wet-armature construction.
- Cartridges are voltage interchangeable.
- Manual override option.
- Industry common cavity.
- Unitized, molded coil design.
- Continuous duty rated solenoid.
- Optional coil voltages and terminations.
- Optional "I" Coil: Weatherproof, Thermal Shock, Immersion Safe.

HYDRAULIC SYMBOL

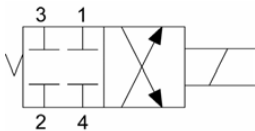

Modes of shift operation to 6 GPM, Consult Factory.

PERFORMANCE

Actual Test Data (Cartridge Only)

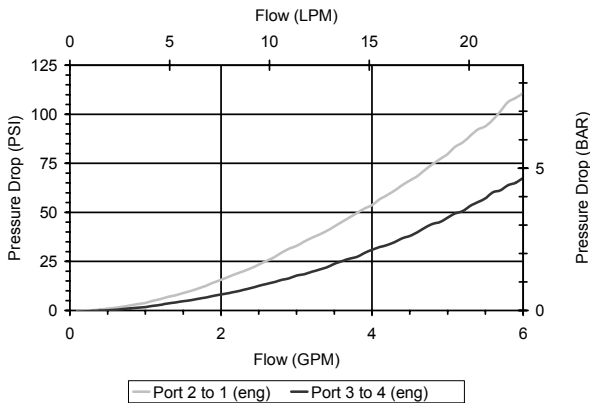

VALVE SPECIFICATIONS

Nominal Flow	4 GPM (15 LPM)
Rated Operating Pressure	3000 PSI (207 bar)
Typical Internal Leakage (150 SSU)	5 cu in/min (82 ml/min) per path
Viscosity Range	36 to 3000 SSU (3 to 647 cSt)
Filtration	ISO 18/16/13
Media Operating Temperature Range	-40° to 250° F (-40° to 120° C)
Weight	.24 lbs. (.11 kg)
Operating Fluid Media	General Purpose Hydraulic Fluid
Cartridge Torque Requirements	25 ft-lbs (34 Nm)
Coil Nut Torque Requirements	4-6 ft-lbs (5.4-8.1 Nm)
Cavity	POWER 4W
Cavity Form Tool (Finishing)	40500029
Seal Kit	21191108

PQS4B00

Solenoid Operated Directional Controls



DIMENSIONS

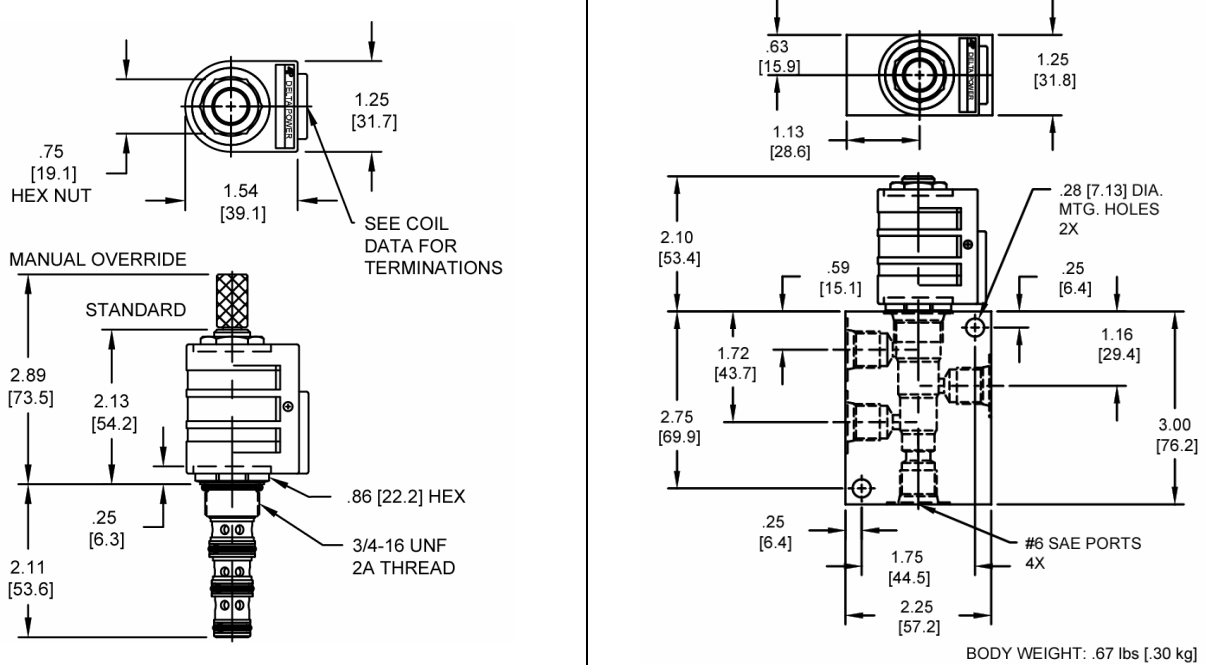

ORDERING INFORMATION

PQ-S4B - - - -

OPTIONS

Buna Standard	00
Viton Standard	V0
Buna, Override, Detent	0M
Viton, Override, Detent	VM
Buna, Override, Non-detent	B1
Viton, Override, Non-detent	V1

BODIES

Blank	
N	1/4 NPTF Ports
S	#6 SAE Ports

VOLTAGE

06	6 VDC
12	12 VDC
24	24 VDC
36	36 VDC
48	48 VDC
25	24 VAC
11	120 VAC
22	220 VAC
44	440 VAC

"P" COIL TERMINATION

(All DC Except as Noted)

DL	Double Lead
DT	Deutsch on Leads DT04-2P
ML	Metri-Pack on Leads
PL	Packard on Leads
WL	Weatherpack on Leads

SS	Single Spade
DS	Double Spade
HC	DIN 43650 (Hirschman) - (AC & DC)
CL	Conduit Lead - (AC Only)
DI	Deutsch - Integral DT04-2P

IMMERSION PROOF "P" TYPE

IA	"I" Coil AMP Superseal - Integral
ID	"I" Coil Deutsch - Integral DT04-2P
IJ	"I" Coil AMP Jr. Timer - Integral
IM	"I" Coil Metri-Pack - Integral

Approximate Coil Weight: .42 lbs (.19 kg.)