

PATENTED SYSTEM

All the control valves belonging to the EX family work according to a principle designed by Hydrocontrol's R&D department and covered by patents EP1860327 (A1) EP1860327 (B1) US2008282691 (A1) and US7581487 (B2).

The valve LS signal is managed according to innovative technique which is an absolute first in the flow sharing world, ensuring:

- elimination of any LS signal bleed off, which can be observed in most systems currently available commercially, and is often the cause of poor compensation accuracy, slow response and excessive sensitivity to operating conditions.
- LS signal picking downstream of the local compensator: this will make signal detection "neater" improving control efficiency and accuracy.

RESPONSE RATE

The EX control valve's strength resides in its quick, prompt response, achieved thanks to the functional advantages built into our patented system. Even the most critical applications such as excavator bucket shacking and the swift dynamics of forestry machinery, usually hard to achieve on flow sharing systems, can be successfully implemented by using EX family products.

ACCURACY AND STABILITY

The unique technical characteristics of the Hydrocontrol's patent allows for outstanding flow control and compensation precision, not likely to be affected even by the most diverse operating conditions. Simultaneous functions are never mutually influenced, not even in the presence of the same load factors (an aspect best highlighted in crawler machinery travelling). System stability itself is greatly benefited by the EX design; the system, also in combination with traditional overcenter valves, appears well balanced and able to effectively reduce oscillation and dynamic instability.

EFFICIENCY

In addition to the well known advantages typically offered by flow sharing systems which, associated with a variable pump, will drastically reduce the machine operating consumption, the EX family introduces a number of interesting options, including pressure relief on the LS signal to further increase energy saving and guarantee top efficiency levels.

FLEXIBILITY

The EX family control valves can be easily adjusted to a variety of applications, thanks to the wide range of available options and different types of available control systems.

COMPACT DIMENSIONS

The carefully designed features and integrated electrohydraulic control ensure a highly compact and optimised layout. Integrated end plates are available in the final working section (only EX54 and EX72), adding to the system dimensional and functional efficiency.

PRIORITY

The EX family allow to install side by side pre-compensated section with post-compensated section. This feature allow to establish a priority in the way the oil is directed and increase the number of application where the EX family can be applied solving technical difficulties that before required external components. Both Inlets and Outlets remain common for the pre and post compensated sections making the assembling of the valve particularly convenient.

APPLICATIONS

Flow Sharing valve for 220 l/min inlet flow rate. Common applications for this control valve are telehandlers, midi-excavators, medium and large sized backhoe loaders, forestry cranes and crane trucks.

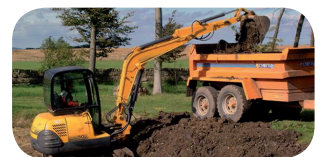

member of



QUICK REFERENCE GUIDE

GENERAL SPECIFICATIONS	EX38	EX46	EX54	EX72
Working section number	1 - 10	1 - 10	1 - 8	1 - 8
CIRCUIT				
Spool stroke (mm)	7	7	9	11
Spool pitch (mm)	38	46	54	72
RATED FLOW				
Pump flow rate (l/min)	150	220	300	450
A/B port flow rate (l/min) (*)	100	180	250	350
RATED PRESSURE				
working pressure inlet port P (bar)	350	350	350	350
BACK PRESSURE MAX				
Max pressure outlet port T (bar)	10	10	10	10

(*) with fixed Pump inlet compensator

OPTION CHART	EX38	EX46	EX54	EX72
LS Signal pressure relief valve	•	•	•	•
Pump pressure relief valve	•	•	•	•
LS Signal dump valve (electric 12/24 Vdc)	•	•	•	•
Pump dump valve (electric 12/24 Vdc)	•	•		
SPOOLS TYPE				
Single acting	•	•	•	•
Double acting	•	•	•	•
Float spool	•	•	•	•
SPOOL ACTUATION				
Hydraulic actuation	•	•	•	•
Mechanical lever actuation	•	•	•	
Mechanical cloche actuation	(•)			
Prop. electrohydraulic actuation 12-24 Vdc (*)	•	•	•	•
ON/OFF electrohydraulic actuation 12-24 Vdc (*)	•	•	•	•
CAN BUS interface actuation	on development	on development	on development	•
SPOOL RETURN ACTION				
Return spring	•	•	•	•
Mechanical detent	•	•		
Pneumatic control	•	•		
Spools displacement sensor (HLPS)	•	•	•	•
PORT RELIEF VALVE				
Direct operated antishock valve			•	•
Anticavitation valve	•	•	•	•
Pilot operated combined valve			•	•
Direct operated combined valve (fixed setting)	•	•		
Plug	•	•	•	•

• = available

(•) = available on request

(*) = we recommend to keep the T line for the electrohydraulic cartridges separate from the T line of the valve.

GENERAL INDEX

4	General specifications Standard working conditions Fluid options Operating principle
6	Hydraulic schema Post Compensated system - Electrohydraulic actuation Post Compensated system - Hydraulic actuation
7	Order example Standard thread Tie-rod kit classification Painting
9	Dimensions HC-EX46 with mechanical lever actuation HC-EX46 with electrohydraulic actuation
11	Typical curves
15	Inlet Section Order example Inlet side classification Combinations valve available Inlet valve arrangement examples Inlet body classification
21	Working section Order example Spool identification Spool flow Spool end identification Spool actuation classification - side A Spool return action classification - side B Work section arrangement Auxiliary valves identification
44	Outlet section (end plate) Order example End plate classification
46	Special functions Parallel connection of several valves High pressure carry over function
48	HC-EX46 Spare parts list
56	Installation and maintenance Guidelines General clamping torque
61	General conditions and patents Product identification

The specifications detailed in this catalogue show standard products. Special applications are available to order subject to contacting our Engineering Department for an estimate. The data and specifications indicated are to be considered a guide only and Hydrocontrol S.p.A. reserves the right to introduce improvements and modifications without prior notice. Hydrocontrol is not responsible for any damage caused by an incorrect use of the product.

GENERAL SPECIFICATIONS

Standard working conditions

Description	Value
Ambient operating temperature range	-40°C / +60°C
Kinematic viscosity range	10 ÷ 300 cSt
Max contamination level	9 (NAS 1638) - 20/18/15 (ISO 4406:1999)
Recommended filtration level	b10 > 75 (ISO 16889:2008)
Internal filter (on electroproportional valves pilot line)	30 µm

All information and diagrams in this catalogue refer to a mineral base oil VG46 at 50°C temperature (32 cSt kinematic viscosity)

Fluid options

Types of fluid (according to ISO 6743/4) Oil and Solutions	Temperature (°C)		Compatible gasket
	min	max	
Mineral Oil HL, HM (or HLP acc. to DIN 51524)	-25	+80	NBR
Oil in water emulsions HFA	+5	+55	NBR
Water in oil emulsions HFB	+5	+55	NBR
Polyglycol-based aqueous solution HFC	-10	+60	NBR

For special applications and different fluids, please call our Technical Department.

Operating principle

The flow sharing technology applied to the standard load sensing system characterizes the new control valves HC-EX. The valve, completely pressure compensated, guarantees great controllability to all actuators, making workport flow dependent only on metering area (spool position). When flow saturation occurs the system reacts by implementing an equal reduction of pressure margin across all spools, generating a proportional reduction of workport flow.

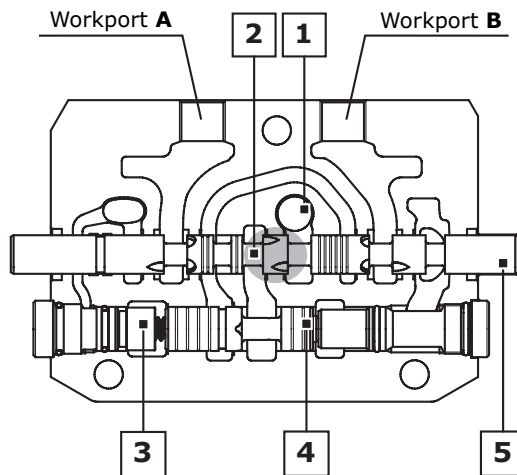

LEGEND:

1. Inlet line (High pressure)
2. Metering notches
3. Load sensing line
4. Local compensator
5. Metering spool

Single section

Referring to picture it's possible to remark some aspects of system functionality. Coming from the common inlet line the main flow, passing across the metering area, reaches local compensator. Metering area, according to the pressure margin, controls the total amount of flow to the workport selected by the main spool. The load sensing signal, picked up downstream the local compensator, feeds the common load-sensing line. When a single section is actuated, the local compensator fully opens to the left side, reaching its complete balanced position. The control of the LS system is made by the inlet compensator for fixed displacement pump or pump compensator for variable displacement pump.

Multi-section

When two or more sections are actuated only one, characterized by the highest pressure (dominant), is involved in the LS signal transmission, working as briefly described in the previous paragraph. The other functions (slaves) become directly dependent on it. The common LS line transfers the information coming from the dominant local compensator to all dependent compensators. Driven by the LS signal, the unbalanced slave compensators activate the pressure compensation creating an artificial pressure drop able to keep pressure margin nominally the same on all the spools. Workport flow becomes only a function of metering area making the system totally load independent.

Flow Sharing function

When saturation occurs the total amount of flow required by actuators is higher than the maximum pump flow rate. The system is able to keep the nominal pressure margin no more. The actual pressure margin reduces according to real flow demand. Since all the local compensators feel the same LS signal and the same pressure drop is applied to different metering areas, then workport flows are reduced proportionally in order to keep all actuators completely under control.

HYDRAULIC SCHEMA

Post compensated system - Electrohydraulic actuation

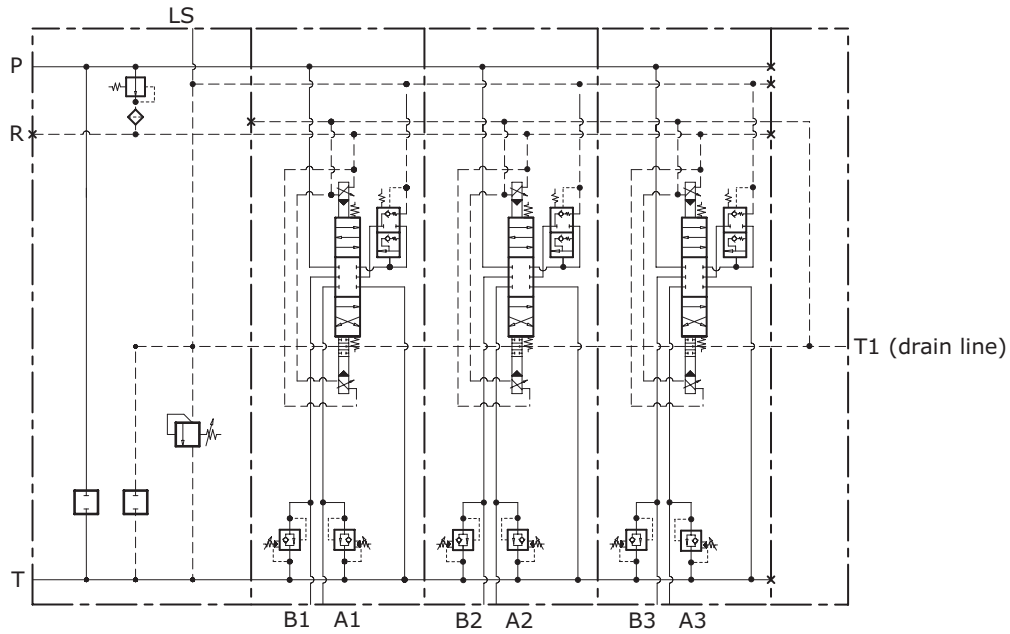

Post compensated system - Hydraulic actuation

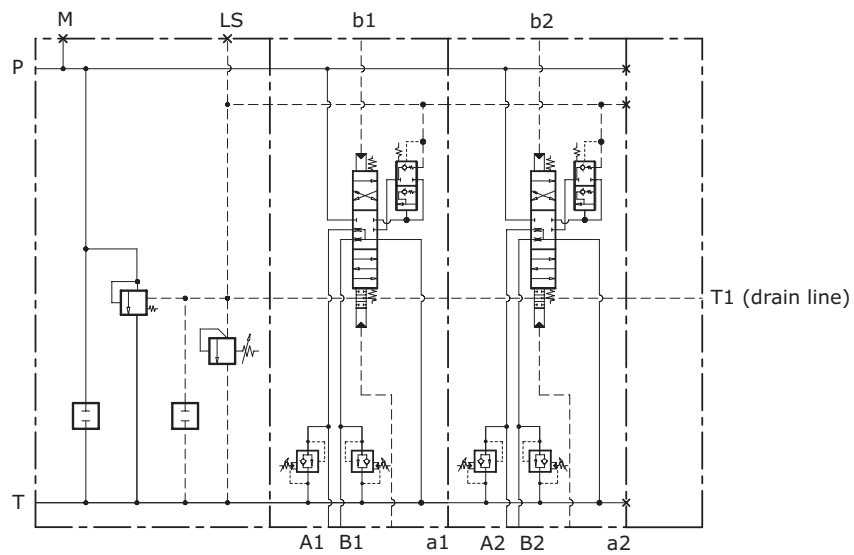

ORDER EXAMPLE

HC-EX46/1: ML V1A 200 V7B C12AJ V10C KV G06 W001C 6060 HP04 FP04 B12AJ RC1 G05 05TF PA 05TF PB KZ20EC

TYPE:

EX46: product type
/1: working section number

1) INLET ARRANGEMENT: p. 15

- ML** Inlet side
- V1A** LS pressure relief valve on port A
- 200** Setting (bar)
- V7B** Full flow relief plug on port B
- C12AJ** Coil-connector kit type
- V10C** LS plug on port C
- KV G06** Inlet body arrangement

2) WORK SECTION ARRANGEMENT: p. 21

- W001C 6060** Spool delivery
- HP04** Spool actuation type
- FP04** Spool return action type
- B12AJ** Coil-connector kit type
- RC1 G05** Work section arrangement
- 05TF PA** Auxiliary valve (port A)
- 05TF PB** Auxiliary valve (port B)

3) OUTLET ARRANGEMENT (END PLATE): p. 36

- KZ20EC** Plate type

Ordering row 2 must be repeated for every work section

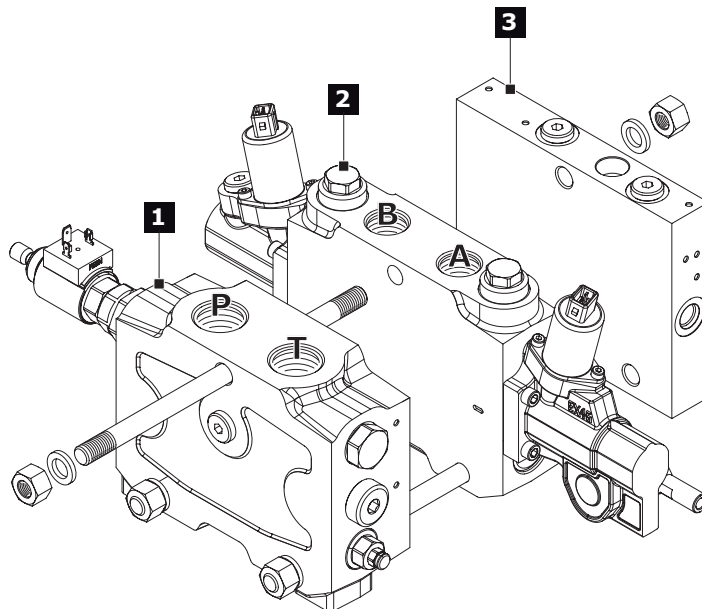

Standard thread

The connection ports size is indicated by an ordering code common for all Hydrocontrol products. Following table shows all available connections; for ordering code refer to table on page 48.

Ports	BSP (ISO - 228)	Code	UN-UNF (ISO - 725)	Code
(P - T)	G 1	G06	1"5/16 - 12 UNF	U06
(A - B)	G 3/4	G05	1"1/16 - 12 UNF	U05

Tie-rod kit classification

Tie rod kit allows the correct assembly of sectional valves. Tie rod's length depends on the number of sections; each valve is assembled with tie rod kits including a tie rod, nut and washer. HC-EX46 requires 3 tie-rod kits

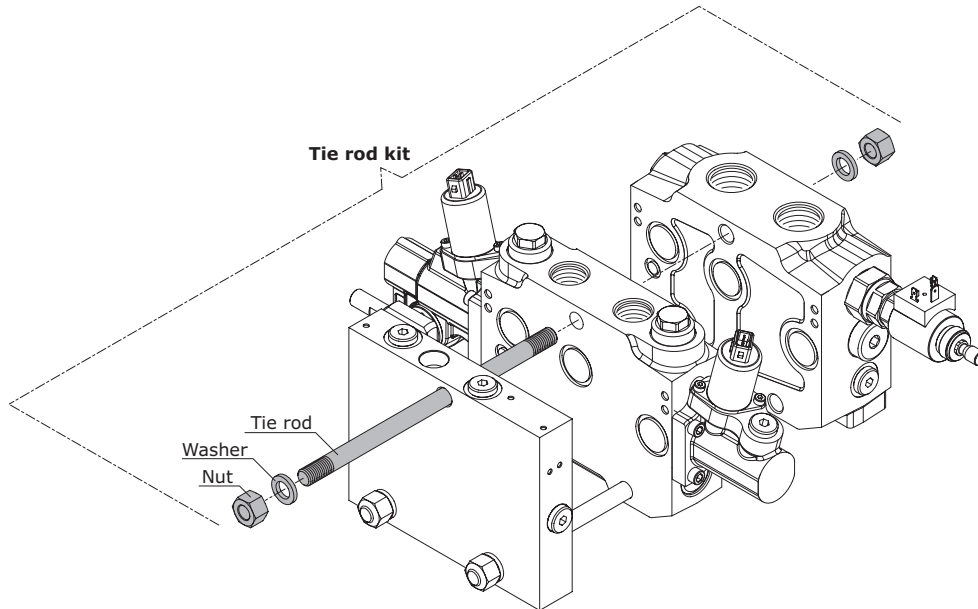

Tie rod kit	Order Code	Lenght (mm)	Clamping Torque (Nm)	Quantity
EX46/1	3001A1007	176		
EX46/2	3001A1008	222		
EX46/3	3001A1006	268		
EX46/4	3001A1005	314		
EX46/5	3001A1009	360		
EX46/6	3001A1010	406	70	3
EX46/7	3001A1011	452		
EX46/8	3001A1012	498		
EX46/9	3001A1013	544		
EX46/10	3001A1014	590		

Painting

On request, all Hydrocontrol valves can be delivered painted (RAL 9005 black primer).

Order example of EX46/1 painted:

HC-EX46/1
ML V1A 200 V7B C12AJ V10C KV G06
W001C 6060 HP04 FP04 B12AJ RC1 G05 05TF PA 05TF PB
KZ20EC

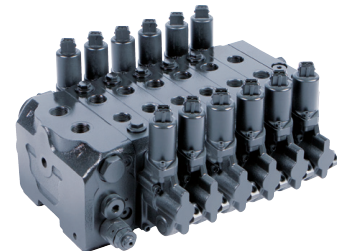
P006/1 N10

The painting is indicated with the following value:

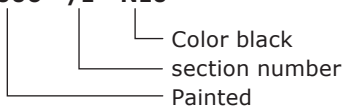
P006 - /1 - N10

DIMENSIONS

HC-EX46 with mechanical lever actuation

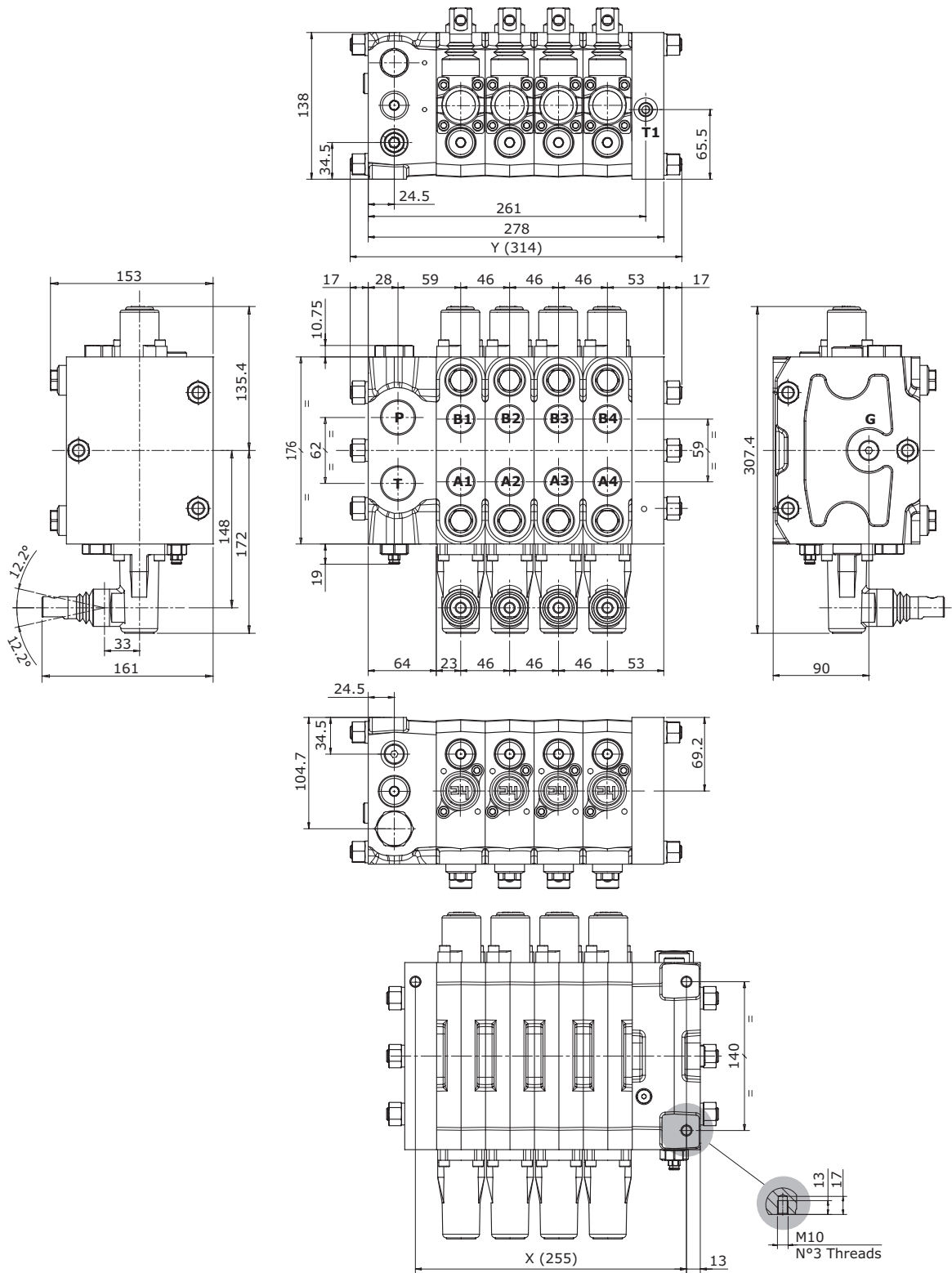

Type	/1	/2	/3	/4	/5	/6	/7	/8	/9	/10
X (mm)	117	163	209	255	301	347	393	439	485	531
Y (mm)	176	222	268	314	360	406	452	498	544	590
Weights (kg)	23.8	30	36.2	42.4	48.6	54.8	61	67.2	74.3	79.6

HC-EX46 with electrohydraulic actuation

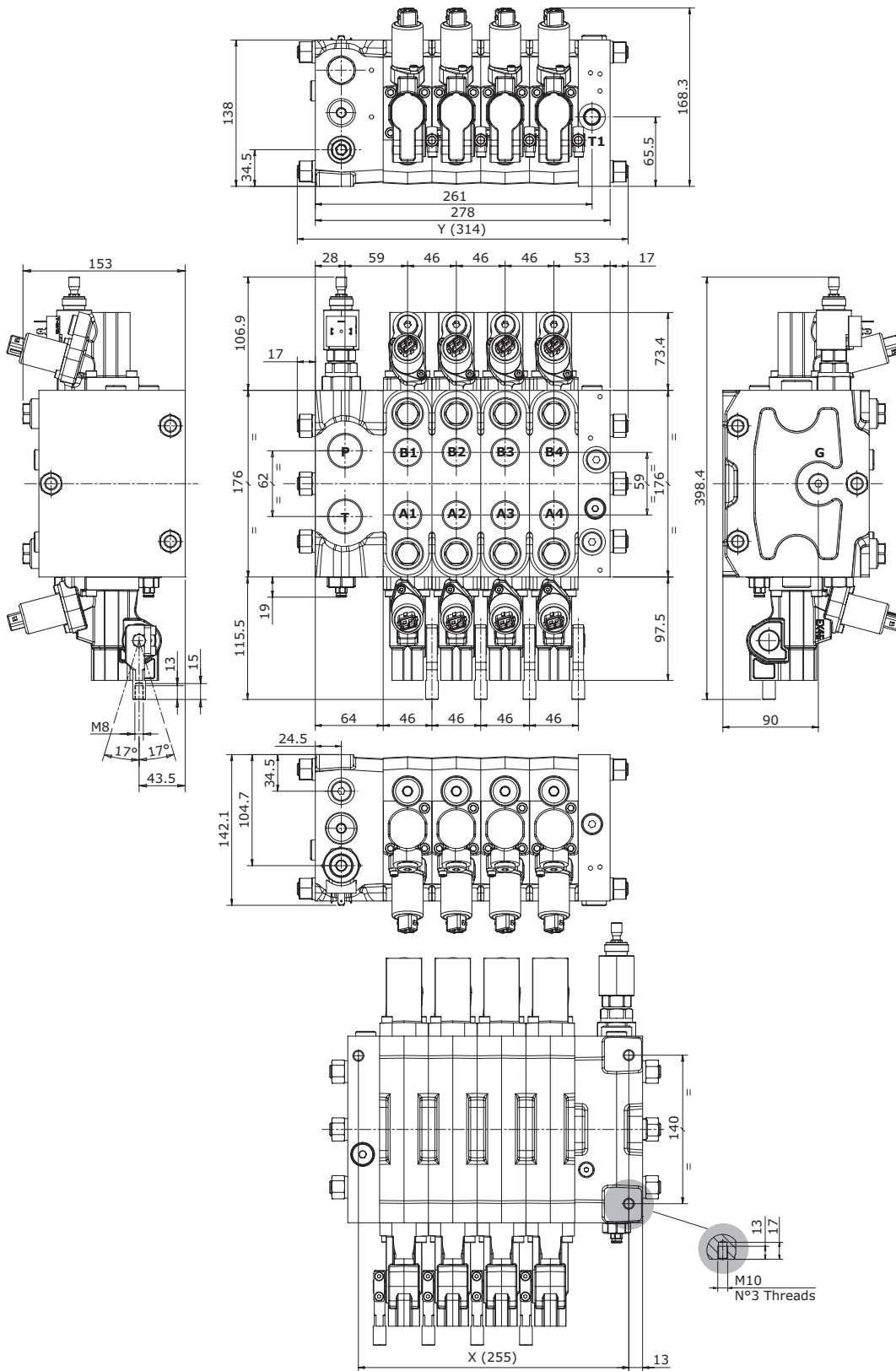

Type	/1	/2	/3	/4	/5	/6	/7	/8	/9	/10
X (mm)	117	163	209	255	301	347	393	439	485	531
Y (mm)	176	222	268	314	360	406	452	498	544	590
Weights (kg)	23.8	30	36.2	42.4	48.6	54.8	61	67.2	74.3	79.6

TYPICAL CURVES

Inlet compensator Pressure drop (P-T)

Fixed displacement system (KV): pressure drop across the inlet compensator as function of pump flow

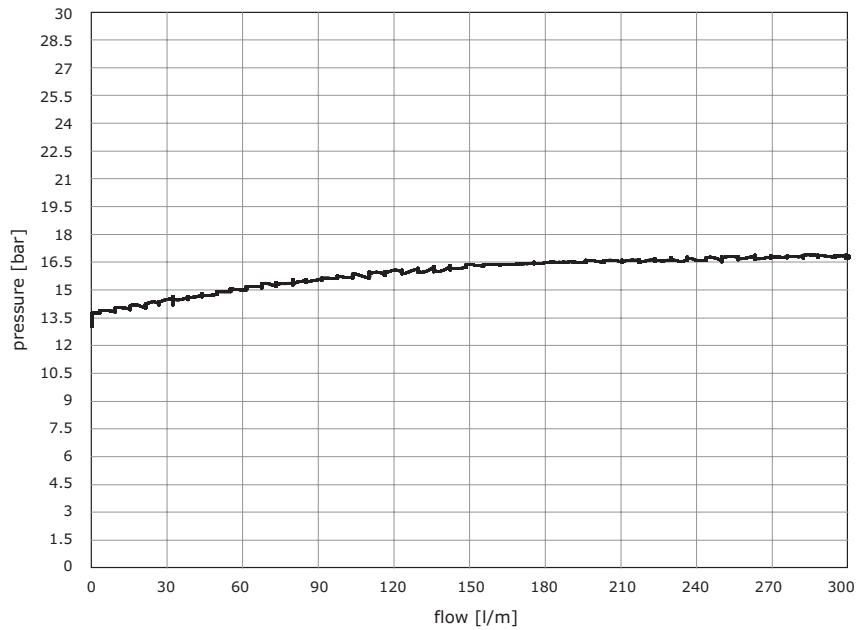
**LS Signal pressure relief valve**

Fixed displacement system (KV): LS Signal pressure relief valve characteristic

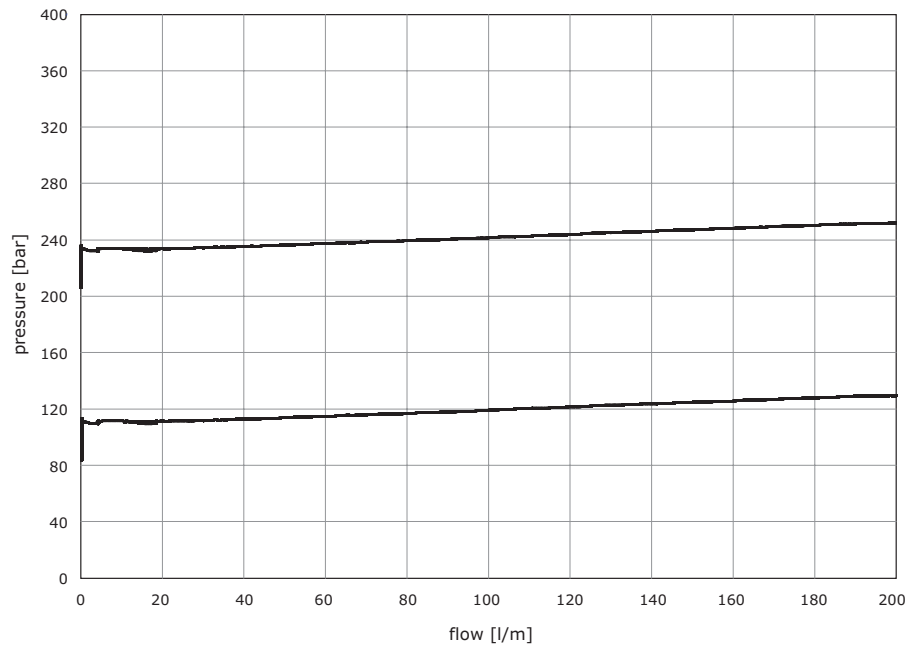

Full flow electric dump valve

Fixed displacement systems (KV): pressure drop across open electric dump valve as function of pump flow

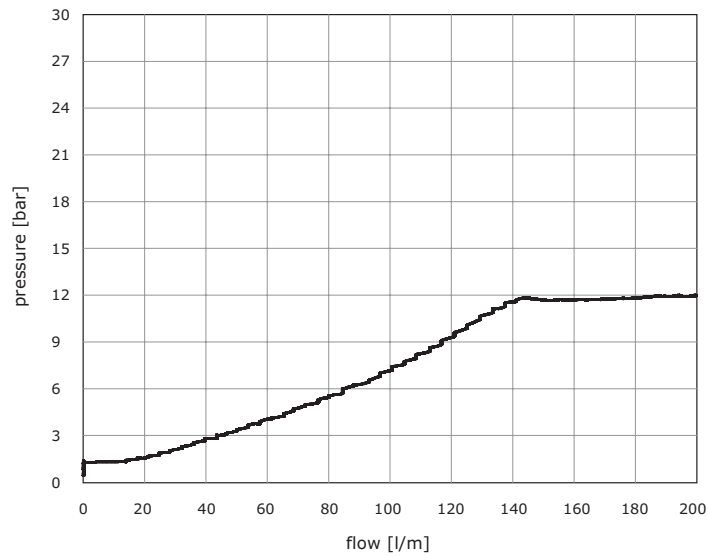

Post compensated spool flow characteristic

Fixed displacement systems (KV): flow on ports A and B as function of spool stroke, pilot pressure, control current
 Inlet flow: 200 l/min

Pump inlet compensator at 17 bar Δp

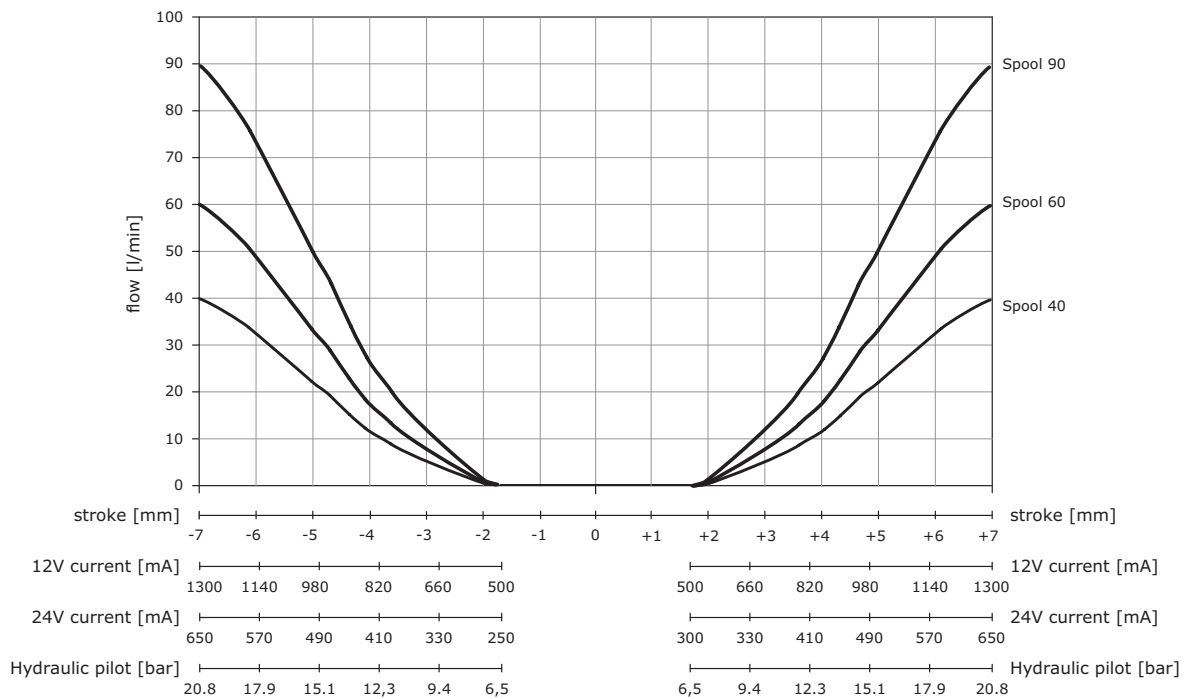

Post compensated spool flow with variable displacement pumps

Variable displacement systems (JV): spools maximum delivered flow as function of pump ΔP setting

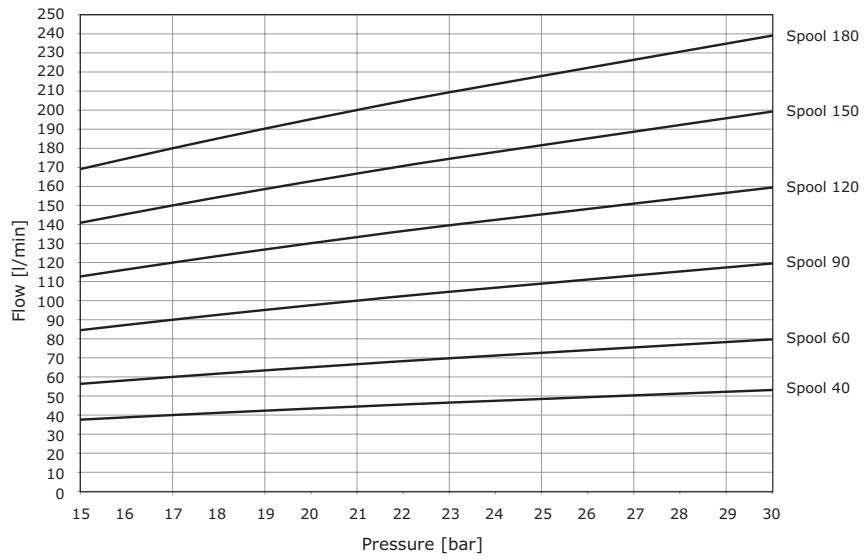

Combined valves (antishock function)

Pressure characteristic as function of flow

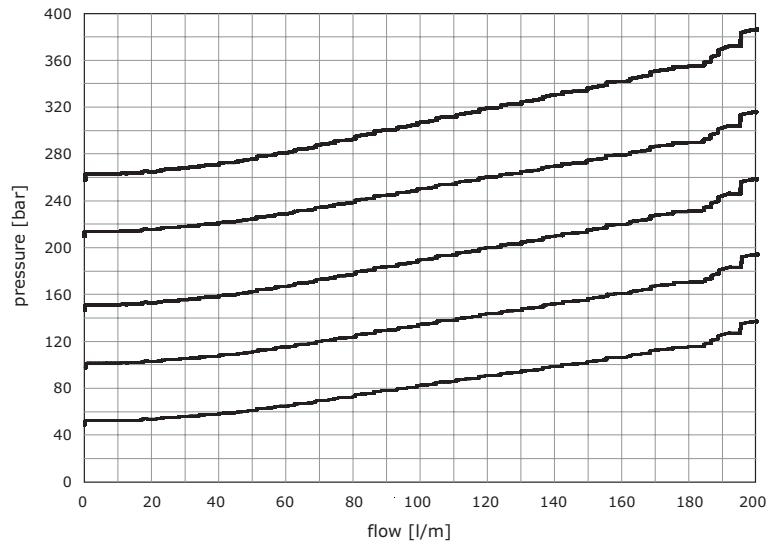

Combined valves (anticavitation function)
Opening and pressure characteristic as function of flow

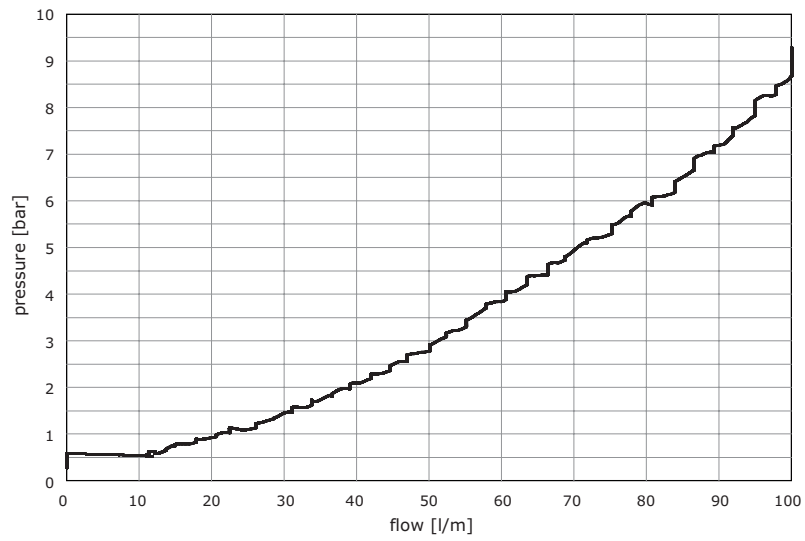

INLET SECTION

Order example

	ML	V1A	200	V7B	C12AJ	V10C	KV G06
1.	ML	Inlet side					
	V1A	LS pressure relief valve on position A					
	200	setting (bar)					
2.	V7B	Full flow electric dump valve on position B					
3.	C12AJ	Coil-Connector kit type					
4.	V10C	LS plug on position C					
5.	KV G06	Inlet body classification					

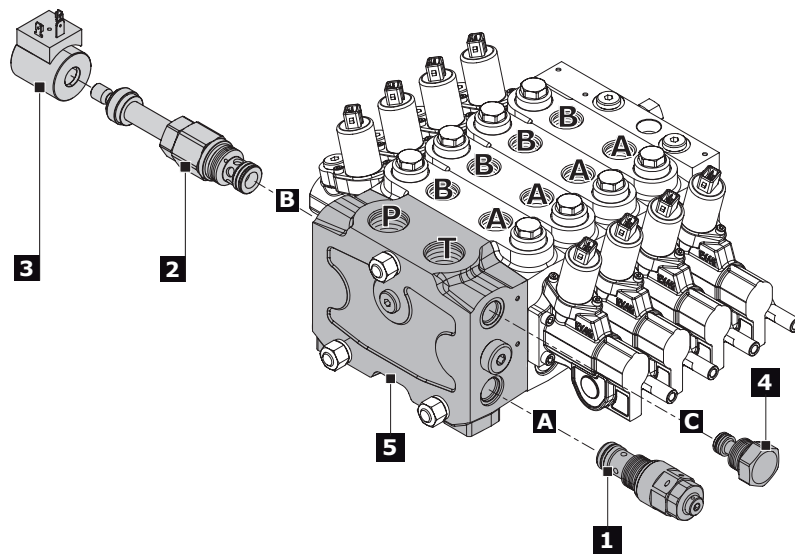

Rif.	Code	Description	Page
-	MR	Flow sharing valve with right inlet section	16
	ML	Flow sharing valve with left inlet section	
1	V1A	LS pressure relief valve - on position A	16
	V2A	LS relief plug - on position A	
2	V3B	Full flow direct operated pressure relief valve - on position B	16
	V4B	Full flow relief plug - on position B	
	V7B	Full flow electric dump valve - on position B	
3	C12AJ	AMP Junior connector - 12 Vdc	18
4	V10C	LS plug - on position C	16
	V11C	LS electric dump valve - on position C	
5	KV G06	Open centre inlet section for fixed displacement pumps (G 1)	19
	JV G06	Closed centre inlet section for variable displacement pumps (G 1)	
	KV U06	Open centre inlet section for fixed displacement pumps (1"5/16 - 12 UN)	
	JV U06	Closed centre inlet section for variable displacement pumps (1"5/16 - 12 UN)	

NOTE: when ordering a relief valve it is necessary to specify factory setting (example 200).

Inlet side classification

MR

Flow sharing valve with **RIGHT INLET** section

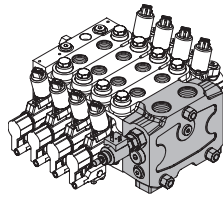

ML

Flow sharing valve with **LEFT INLET** section

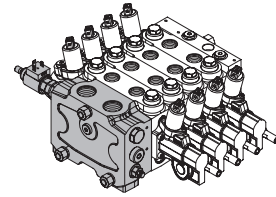

Order code	Schema		Description	Setting Range (bar)
V1A			LS pressure relief valve	50 - 250
				251 - 350
V2A			LS relief plug	
V3B			Full flow direct operated pressure relief valve	50 - 350
V4B			Full flow relief plug	
V7B			Full flow electric dump valve	
V10C			LS plug	
V11C			LS electric dump valve	

Combinations valve available

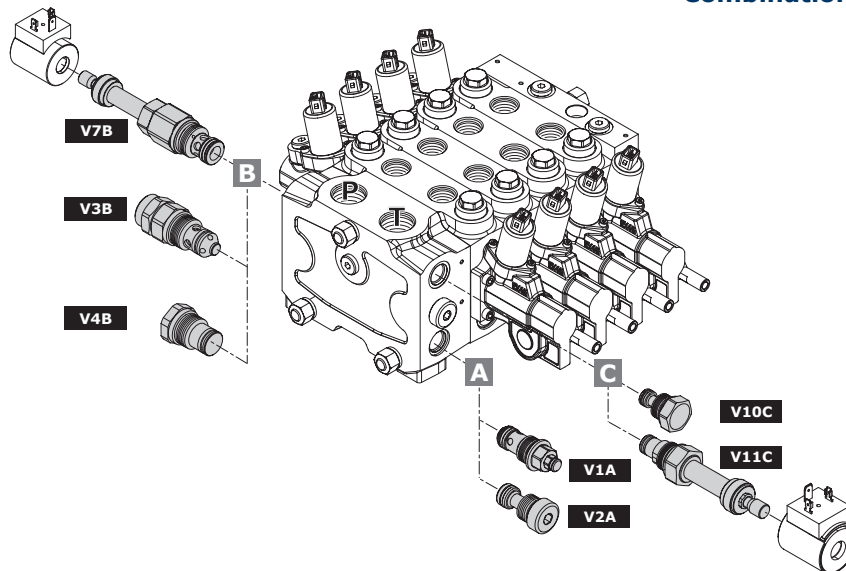

COMBINATION	V1A	V2A	V3B	V4B	V7B	V10C	V11C
V1A - V3B - V10C	•		•			•	
V1A - V3B - V11C	•		•				•
V1A - V4B - V10C	•			•		•	
V1A - V4B - V11C	•			•			•
V1A - V7B - V10C	•				•	•	
V2A - V4B - V10C		•		•		•	
V2A - V4B - V11C		•		•			•
V2A - V7B - V10C		•			•	•	

Inlet valve arrangement examples

NOTE:

when ordering a valve type V1A or V3B, it is necessary to specify pressure setting.

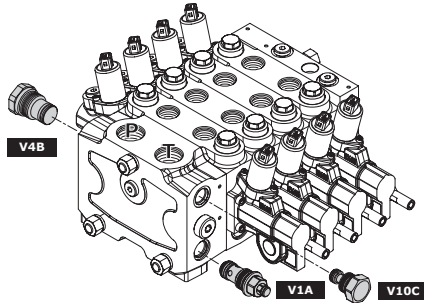

ML - V1A (200) - V4B - V10C - KV G05

- V1A** LS relief valve on position A
- 200** setting (bar)
- V4B** Full flow relief plug on position B
- V10C** LS plug on position C

NOTE:

requires minimum 40 bar difference in setting of valve V1A (LS relief valve) and valve V3B (Full flow relief valve)

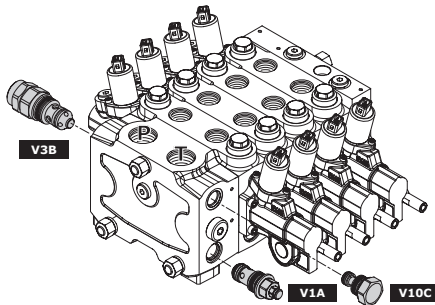

ML - V1A (200) - V3B (240) - V10C - KV G05

- V1A** LS relief valve on position A
- 200** setting (bar) pressure relief valve
- V3B** Full flow relief plug on position B
- 240** setting (bar) Full flow pilot operated pressure relief valve
- V10C** LS plug on position C

NOTE:

when ordering a valve type V7B, it is necessary to specify connector type (see table "A" page 18)

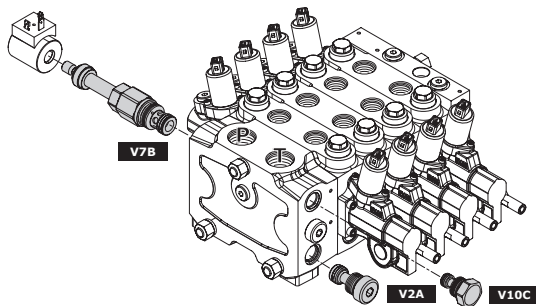

ML - V2A - V7B (C12AJ) - V10C - KV G05

- V2A** LS relief plug on position A
- V7B** Full flow electric dump valve
- C12DI** Connector DIN - 12 Vdc
- V10C** LS plug on position C

NOTE:

when ordering a valve type V11C, it is necessary to specify connector type (see table "A" page 18)

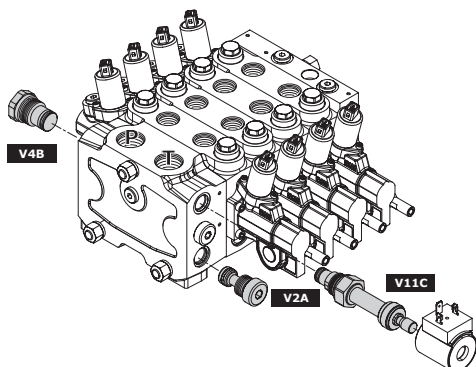

ML - V2A - V4B - V11C (C24DE) - KV G05

- V2A** LS relief plug on position A
- V4B** Full flow relief plug on position B
- V11C** LS electric dump valve on position C
- C24DE** Connector DEUTSCH - 24 Vdc

Table "A"

Coil and Connectors specifications for inlet section

Coil kit must be ordered separately

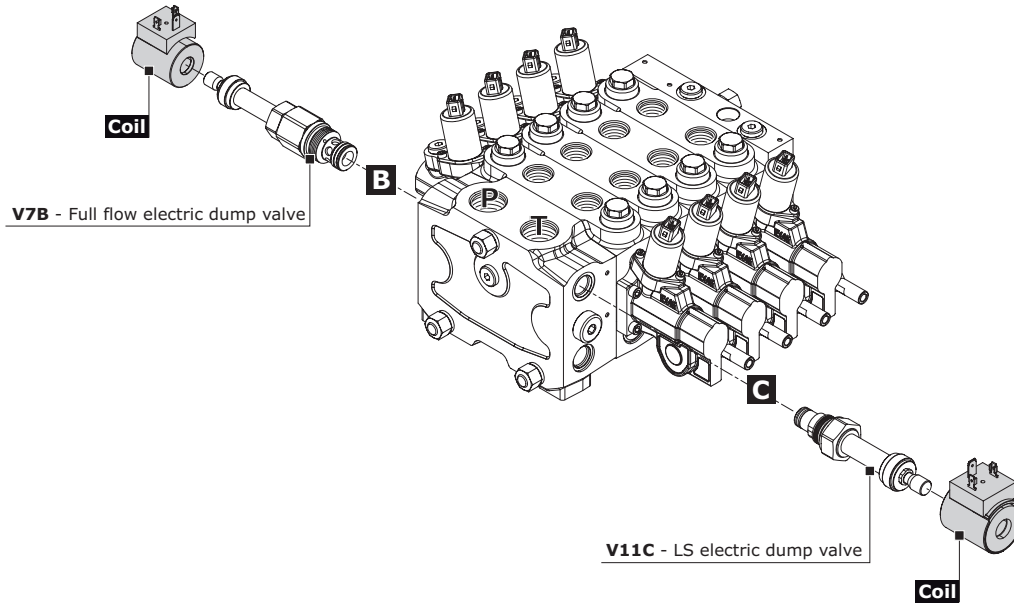

COIL TYPE	ORDER CODE	SUPPLY VOLTAGE (Vdc)	WHEATHER PROTECTION	COIL RESISTANCE R ₂₀ (Ω)	CONNECTOR MATERIAL	COIL BODY	DUTY CYCLE	COIL INSULATION	POWER
DIN 43650 ISO 4400	C12DI	413171235	12	IP65					
	C24DI	413172432	24						
DEUTSCH DT 4	C12DE	413171238	12	IP67	Nylon	Zinc plated steel	ED 100%	Class H coil as from IEC 85 standard	20.5 W
	C24DE	413172440	24						
AMP JUNIOR	C12AJ	413171237	12 Vdc	IP65					
	C24AJ	413172433	24 Vdc						

NOTE: mating connector for DIN 43650 can be ordered separately with code 413000313.

Inlet body classification

The inlet section with KV configuration enables control valve usage with fixed displacement pumps. With this configuration the presence of LS relief valve (valve type 1) is suitable to adjust the system maximum pressure. Full flow electric dump valve (valve type 7) can also be added as safety device. The inlet section with JV configuration enables control valve usage with variable displacement pumps. With this configuration the presence of LS relief valve (valve type 1) is suitable to adjust the system maximum pressure. LS electric dump valve (valve type 11) can also be added as safety device. An additional full flow relief valve (valve type 3) can be added to protect the system from pump regulator failures. Additional solution for variable displacement pumps is available on request to allow a constant reduced free flow in stand by condition through the system: this is sometime required to guarantee a stand by flow for oil cooling.

INLET BODY ARRANGEMENT AND THREAD AVAILABLE		
code	schema	description
KV G06		Open centre inlet section for fixed displacement pumps
KV U06		
JV G06		Closed centre inlet section for variable displacement pumps
JV U06		

NOTE:

transformation of the inlet section from closed center to open center and vice versa is possible by ordering the appropriate kit 3200A1013 or 3200A1014 (see page 20)

Trasformation kits

Transformation on the inlet section from open center to closed center is possible by ordering the complete kit code: **3200A1013 (transformation kit from KV to JV)**

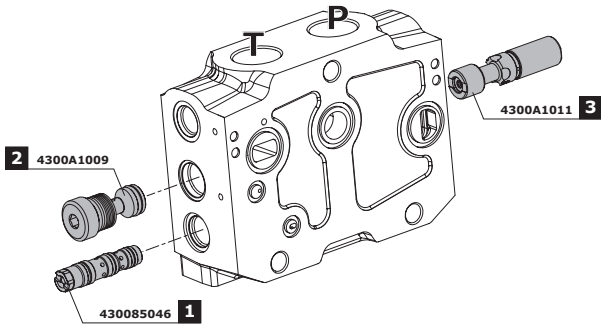

**OPEN CENTER CONFIGURATION (JV)
VARIABLE PUMP**

Ref.	order code	Description	Q.ty
1	430085012	Inlet compensator kit	1
2	4300A1009	Valve kit	1
3	4300A1011	Spool assembly	1

**Complete transformation kit:
order code - 3200A1013**

Transformation on the inlet section from closed center to open center is possible by ordering the complete kit code: **3200A1014 (transformation kit from JV to KV)**

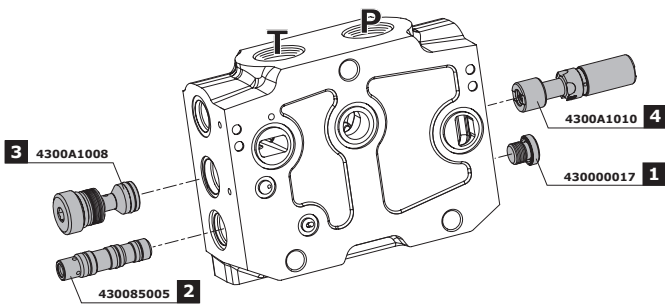

**OPEN CENTER CONFIGURATION (KV)
FIXED PUMP**

Ref.	order code	Description	Q.ty
1	430000017	Plug G1/4"	1
2	430085004	Inlet compensator plug kit	1
3	4300A1008	Plug kit	1
4	4300A1010	Spool assembly	1

**Complete transformation kit:
order code - 3200A1014**

WORKING SECTION

Order example:

W001C 6060	HP04	FP04	B12AJ	RC1 G05	05TF PA	05TF PB
-------------------	-------------	-------------	--------------	----------------	----------------	----------------

1. **W001C 6060** spool type
2. **HP04** spool actuation type
3. **FP04** spool return action type
4. **B12AJ** coil-connector kit type
5. **RC1 G05** section type
6. **05TF PA** auxiliary valve type (port A)
7. **05TF PB** auxiliary valve type (port B)

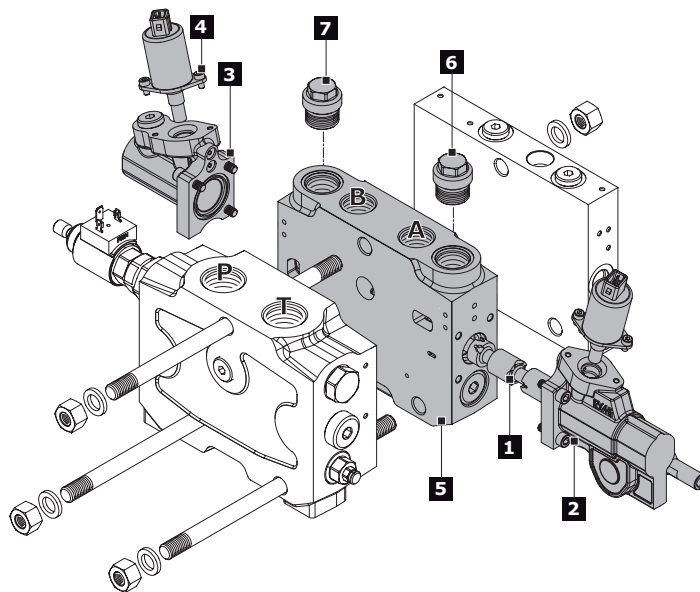

Rif.	Code	Description	Page
1	W001C 6060	3 positions double-acting (6060 = l/min Spool flow)	22
	W002C 6060	3 positions double-acting A-B to tank (6060 = l/min Spool flow)	
2	H001	Lever actuation	25
	HP04	Lever actuation + electrohydraulic actuation	
	HP05A	hydraulic actuation (pilot ports on the top)	
3	F001A	3 positions spring-centred spool (spring A)	28
	FP04	Electrohydraulic return action	
4	B12AJ	Solenoid kit 12 vdc (AMP connector)	31
	B24AJ	Solenoid kit 24 vdc (AMP connector)	
5	RC1 G05	Post-Compensated section with auxiliary valve (G 3/4)	33
	RC2 G05	Post-Compensated section without auxiliary valve (G 3/4)	
	RC1 U05	Post-Compensated section with auxiliary valve (1"5/16-12 UN)	
	RC2 U05	Post-Compensated section without auxiliary valve (1"5/16-12 UN)	
6	03TF PA 350	Fixed setting combined valve (port A)	35
	05TF PA	Fixed setting Prearrang. for aux. valve (port A)	
7	03TF PB 350	Fixed setting combined valve (port B)	35
	05TF PB	Fixed setting Prearrang. for aux. valve (port B)	

EX46 work sections are available in **POST COMPENSATED** configuration.

- Sections designed to house auxiliary valve option require double choice on work ports A and port B.
- Always indicate setting value when using fixed setting combined valve: 03TF PA (120) - 03TF PB (120)
- When ordering a section with electrohydraulic actuation, it is necessary to specify Solenoid type (page 31).

Spool identification

Each work section contains a spool; each spool is compatible with all actuations.
 For the correct operation of all actuations, each work section requires a spool end which changes according to the type of actuations. (see tables "C" on page 23)

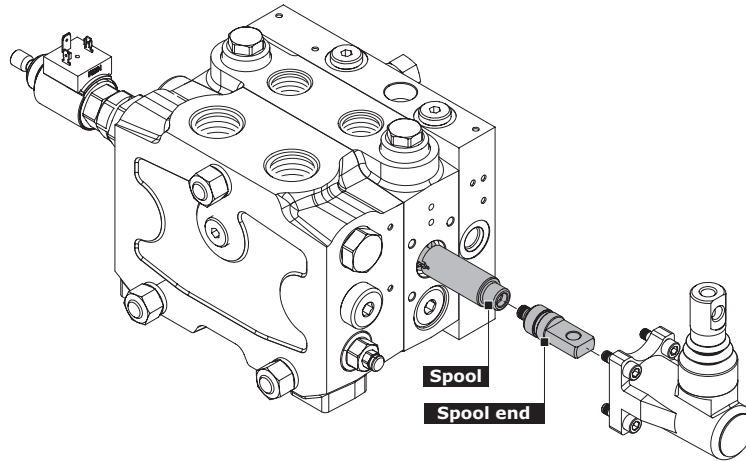

POST - COMPENSATED SECTION		
Code	Description	Schema
W001C	3 positions double-acting	
W002C	3 positions double-acting A and B to tank	



Spool flow

Flow rates delivered to the A and B ports are identified in following table. Rated flows refer to simmetrical spools.

POST - COMPENSATED SECTION (flow rates l/min)						
Spool type	4040	6060	9090	120120	150150	1808180
W001C	•	•	•	•	•	•
W002C	•	•	•	•	•	•

Spool end identification (Tables "C")

All work section contain end spool, that changes as a function of spool actuation control.

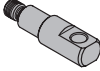
POST - COMPENSATED SECTION		
Code	Description	Layout
422501286	Pin hole end (only available with H001 actuation)	
	Male clevis end (only available with H004 actuation)	
420314019	Pin hole end (Available with hydraulic actuation)	
422501284	Pin hole end (Only Available with electrohydraulic actuation) Already included in electrohydraulic kits	

Spool with restricted service ports

Code	Circuit	Restriction on diameter (mm)	Section (mm ²)	Schema
J10	A-B IN T	0,10	2,19	
K10	A IN T	0,10	2,19	
Y10	B IN T	0,10	2,19	

Classification spool example

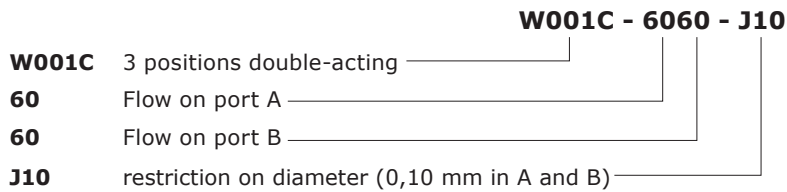

NOTE:

- not simmetric spools (such as 4060, 6090...) are available on request; for availability we suggest to contact our Sales department.
- rated flows are defined for 17 bar ΔP (as per KV inlet arrangement); for different ΔP values on variable pump systems, refer to diagram on page 12 (Post compensated spool flow with variable displacement pumps).

Spool actuation classification - SIDE A

Spool actuations are divided in three types:

- Mechanical lever actuation
- Hydraulic actuation
- Electrohydraulic actuation.

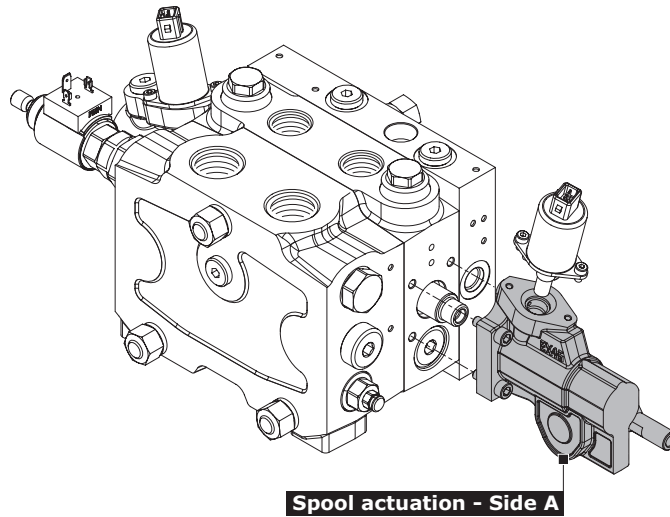

MECHANICAL LEVER ACTUATION			
Code	Description	Dimensions	Configuration
H001	Lever actuation (only with manual and hydraulic section body)		
H004	Without lever actuation (only with manual and hydraulic section body)		

NOTE:

- H001 and H004 require the choice of spool return action (side B)
- H001 and H004 require a mechanical version body.

HYDRAULIC ACTUATION			
Code	Description	Dimensions	Configuration
HP05A	Hydraulic actuation (pilot ports on the top) (only with manual and hydraulic section body)		
HP05C	Hydraulic actuation (pilot ports on the sides) (only with manual and hydraulic section body)		
HP05L	Hydraulic actuation with stroke limiter (only with manual and hydraulic section body)		

HYDRAULIC ACTUATION SPECIFICATIONS		
Regulating pressure (bar)	6,5	20,8
Max Pressure on pilot line (bar)	40	
Max Pressure on pilot Tank line (bar)	5	

NOTE:

- HP05A, HP05C, HP05L are different between Post-compensated and Pre-compensated sections.
- Leave out the spool return action code when choosing hydraulic actuation HP05A, HP05C and HP05L
- H001, H004, HP05A, HP05C, HP05L requires a mechanical version body.
- All hydraulics actuation are available in BSP or UNF version: (Port Pilot: 1/4" BSP or 9/16" UNF)
- Recommended control curve for HC Remote Control: A01 for standard spool, A07 for float spool

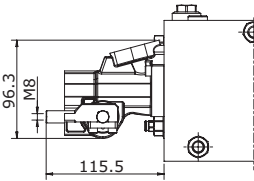
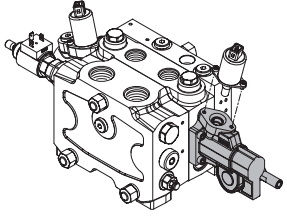
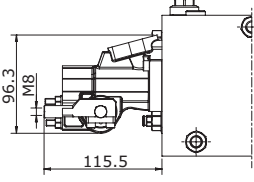
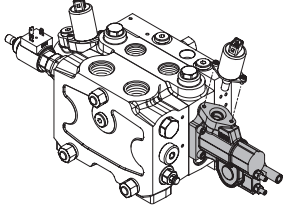
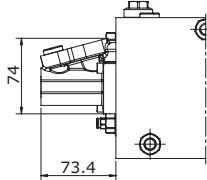
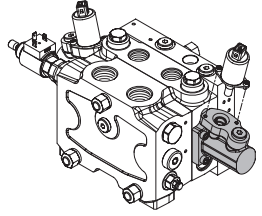
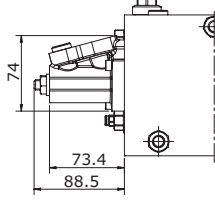
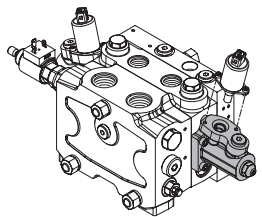
ELECTROHYDRAULIC ACTUATION			
Code	Description	Dimensions	Configuration
HP04	Lever actuation + electrohydraulic actuation		
HP04L	Lever actuation + electrohydraulic actuation with stroke limiter		
HP07	Without lever + electrohydraulic actuation		
HP07L	Without lever + electrohydraulic actuation with stroke limiter		

NOTE:

Require electrohydraulic version body. External drainage recommended (see page 37).

Spools return action classification - SIDE B

Spool return action are mandatory for all mechanical actuations and for all electrohydraulics actuation. Spool return action are divided in two types:

- Mechanical lever spool return action
- Electrohydraulic spool return action.

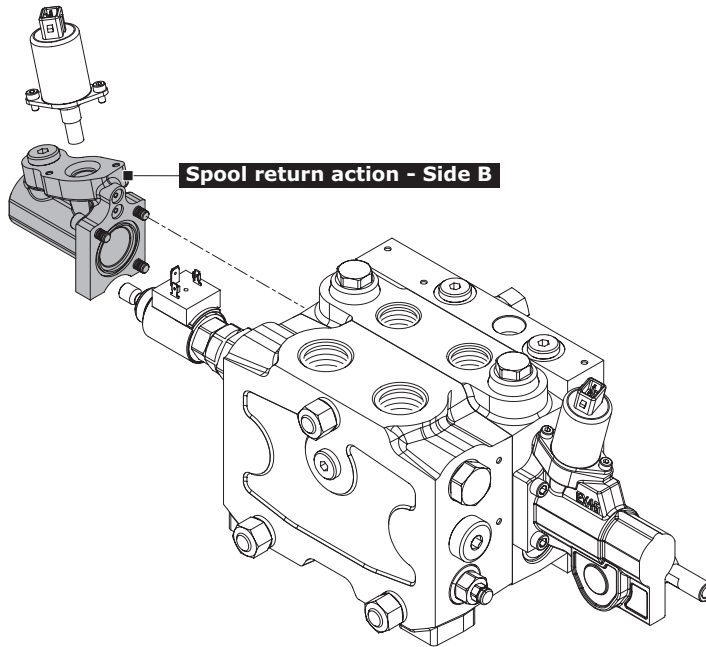

NOTE:

- F001A, F001B, F002A, F022A, F023A, F126A and F127A requires a mechanical version body.

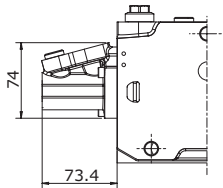
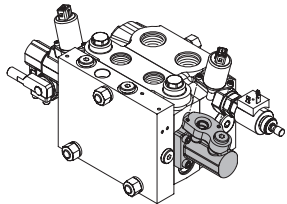
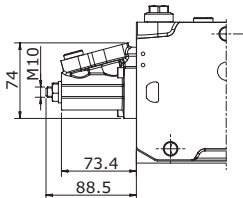
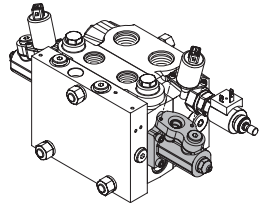
ELECTROHYDRAULIC SPOOL RETURN ACTION			
Code	Description	Dimensions	Configuration
FP04	Lever actuation + electrohydraulic actuation available with HP04 - HP04L - HP07		
FP07L	Lever actuation + electrohydraulic actuation with stroke limiter Only available with HP07L		

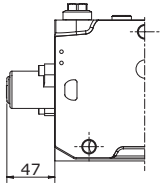
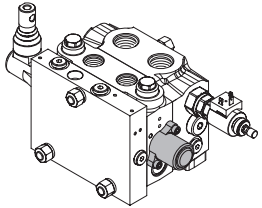
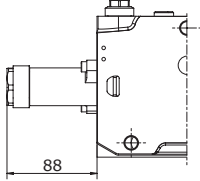
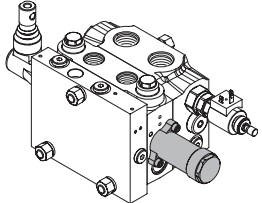
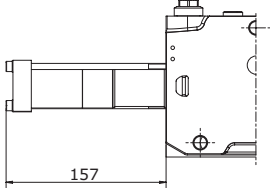
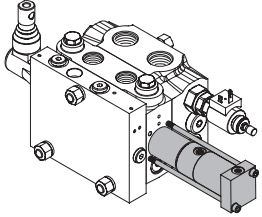
MECHANICAL LEVER SPOOL RETURN ACTION			
Code	Description	Dimensions	Configuration
F001A	3 position spring centered spool		
F001B			
F002A	Detent in A and B		
F022A	Proportional Pneumatic control (port BSP: G 1/8)		
F023A	Proportional Pneumatic control rotated 180° (port BSP: G 1/8)		
F126A	Proportional Pneumatic control (port NPTF: 1/8-27)		
F127A	Proportional Pneumatic control rotated 180° (port NPTF: 1/8-27)		

Hall effect Linear Position Sensor HLPS2

HLPS is a Hall effect sensor based device used in conjunction with spool position transducer kits available for HC-EX46. HC-HLPS is based on a state of the art programmable Hall effect sensor device; after the final assembly of the valve a computer assisted calibration procedure is performed that compensates for mechanical inaccuracies and uncertainties allowing to attain high accuracy and linearity in spool position detection. Spool position is output as an analog voltage signal in the 0.5 - 4.5V range. The unit works in 12V and 24V environments and is protected against load-dump and other major electrical faults. Fault signalling is carried out through the output signal. HLPS with the companion mechanical kit is therefore applicable in close loop feedback control applications and whenever determining spool position reliably is, as in safety functions, a major concern.

ELECTROHYDRAULIC ACTUATION

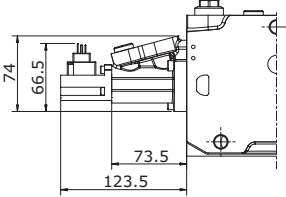
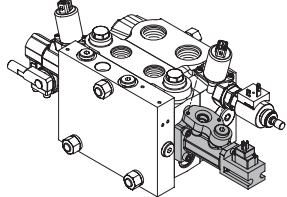
Code	Description	Dimensions	Configuration
FP04S	Spool position indicator for electrohydraulic actuation Only available with HP04 - HP07		

Technical specifications

Electrical	
Operating voltage	6 - 30 Vdc
Max current consumption	20.5 mA
Output	
Output voltage spanning	0.5 - 4.5 Vdc
Quiescent voltage	2.5 Vdc
Output current	-1 - +1 mA
Minimum output load resistance	4.5 kOhm
Overall accuracy	± 2.5%
Resolution	12 bit
Fault signalling levels	4.8V < Vout < 0.2 Vdc
Protections	short circuit protection, reverse, battery protection, thermal shutdown, overvoltage, undervoltage, load-dump > 60 Vdc/m
EM Immunity	
Mechanical, Environmental	
Operating temperature	-40 / +85 °C
Ingress Protection Rating	IP 65
Dimensions	28 x 18 x 23 mm (L x W x H)
Connections	
I/O	DIN 43650-C male
PIN 1	Vout
PIN 2	Vcc
PIN 3	OV
PIN 4	Chassis (connected to valve body)
Applied Standards	
Immunity for industrial environments	EN 61000-6-2
Emission standard for residential commercial and light-industrial environments	EN 61000-6-3
EMC - Agricultural and forestry machines	EN 14982
EMC - Earth-moving machinery	ISO 13766

NOTE: mating connector for DIN 43650-C can be ordered separately with code 487200314

Solenoid specifications for Electrohydraulic actuation

Solenoid kit must be ordered separately. Each work section require two solenoid kit.

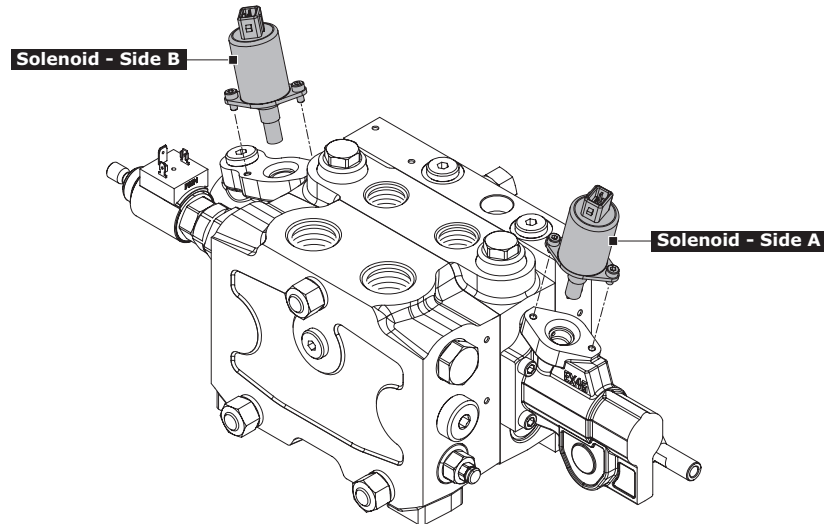

COIL AND CONNECTOR SPECIFICATIONS				
Type	DEUTSCH DT 4		AMP JUNIOR POWER TIMER	
Order Code	B12DE	B24DE	B12AJ	B24AJ
	430093102	430093103	430093100	430093101
Supply voltage (Vdc)	12	24	12	24
Coil resistance R_{20} (Ω)	4,7	20,8	4,7	20,8
ON-OFF control current (mA)	2500	1150	2500	1150
Proportional control current (mA)	500 - 1300	250 - 650	500 - 1300	250 - 650
PWM frequency suggested (Hz)	70 - 90		70 - 90	
Connector	DEUTSCH DT 4		AMP Junior Power Timer	
Feeding reducing pressure (bar)	40		40	
Max Pressure on pilot Tank line (bar)	5		5	

NOTE:

Mating connector for AMP Junior Power Timer can be ordered separately with code 413000223 (including 2 m wire).
Mating connector for Deutsch DT 4 can be ordered separately with code 487200802.

Compatibility table

COMBINATION		SPOOL ACTION AND RETURN SPRING TYPE - SIDE B										
		F001A	F001B	F002A	F022A	F023A	F126A	F127A	FP04	FP07L	FP04S	FP07
SPOOL ACTION AND RETURN SPRING TYPE - SIDE A	H001	•	•	•	•	•	•	•				
	H004	•	•	•	•	•	•	•				
	HP05A											
	HP05C											
	HP05L											
	HP04								•		•	
	HP04L								•			
	HP07								•		•	
	HP07L									•		

NOTE:

Leave out the spool return action code when choosing hydraulic actuation HP05A, HP05C and HP05L

Work section arrangement

Following pages are showing ordering code for post compensated section in their standard version and in combination with some specific applicable devices.

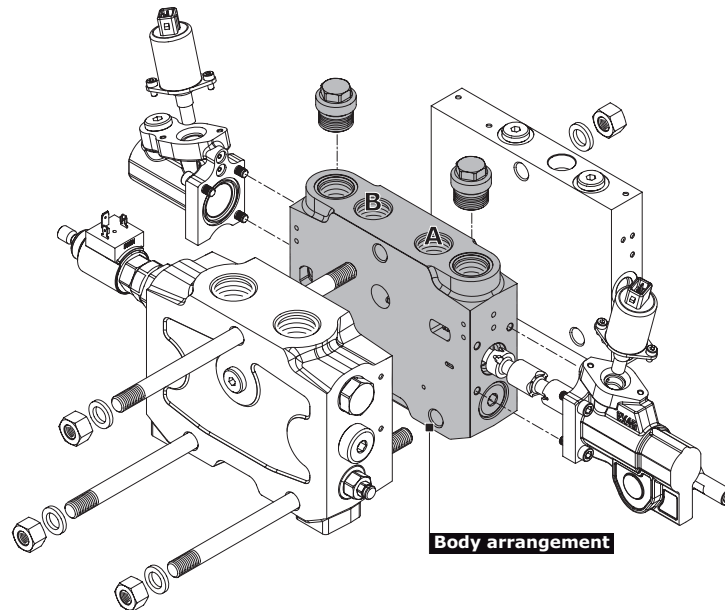

Work section available

Functions	Order code	Type
Standard section	RC1	with auxiliary valve
	RC2	without auxiliary valve

NOTE:





- Section with **local LS relief valve** and Section with **additional port for remoted LS relief valve** are on development.



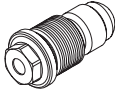

POST compensated arrangement

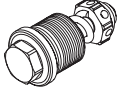
STANDARD SECTION			
code	schema for mechanical lever actuation	schema for electrohydraulic actuation	description
RC1 G05			<p>POST COMPENSATED section</p> <p>Arranged for auxiliary valves</p>
RC1 U05			
RC2 G05			<p>POST COMPENSATED section</p> <p>Not arranged for auxiliary valves</p>
RC2 U05			

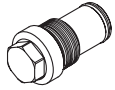
Auxiliary valve identification

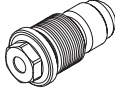
Valve setting is defined at 10 l/min flow. Look at Auxiliary valves diagram on page 14 to evaluate setting at actual flow.

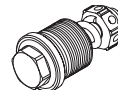
code	description	schema	configuration	setting range (bar)	
02TF PA	Fixed setting Anticavitation valve (port A)				
03TF PA	Fixed setting combined valve (port A)			A	40 / 350
05TF PA	Fixed setting Prearrangement for auxiliary valve (port A)				

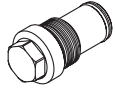
code	description	schema	configuration	setting range (bar)	
02TF PB	Fixed setting Anticavitation valve (port B)				
03TF PB	Fixed setting combined valve (port B)			A	40 / 350
05TF PB	Fixed setting Prearrangement for auxiliary valve (port B)				

Auxiliary valve - Setting range

Sections designed to house auxiliary valve option require double choice on work ports A and B.
Always indicate setting value when using fixed setting combined valve:

03TF PA (120) = setting

NOTE:

Auxiliary valves are not adjustable: factory settings are available from 40 to 350 bar with 10 bar steps

OUTLET SECTION (END PLATE)

There are two main types of End Plate:

- **Manual and Hydraulic actuation version:** to be used when no electrohydraulic controls are present in the valve: this plate is simply collecting the LS signal drain that can be connected to tank internally or externally without significant differences

- **Electrohydraulic version:** to be used when at least one section in the valve has electrohydraulic actuation: this plate is collecting LS signal and electrohydraulic controls drain and is providing electrohydraulic actuation feeding by means of a pressure reducing valve

IMPORTANT:

with electrohydraulic actuation, only external drain outlet is provided. We recommend to connect drain directly to tank without any other additional pressure drop, in order to avoid control system damages and poor control properties.

Order example

KZ20EC

1. **KZ20EC** Outlet section type _____

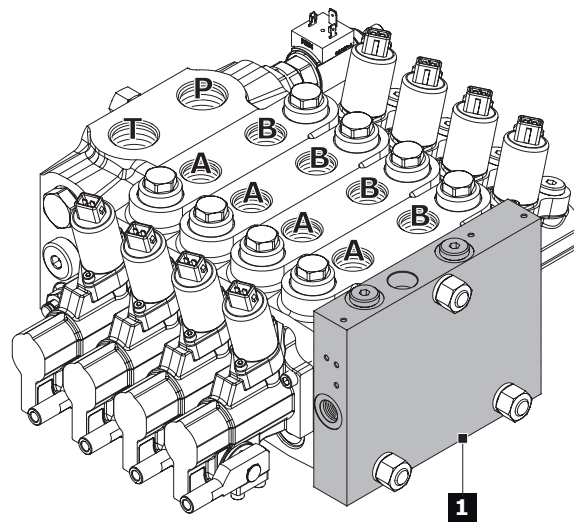

Rif.	Code	Description	Page
1	KZ10I	End plate without RDP internal drain (only for manual and hydraulic actuation)	37
	KZ10E	End plate without RDP external drain (only for manual and hydraulic actuation)	
	KZ20EC	End plate with RDP external drain (only for electrohydraulic actuation)	
	KZ20EH	End plate with RDP external-side drain (only for electrohydraulic actuation)	

NOTE:

we recommend to keep the T line for the electrohydraulic cartridges separate from the T line of the valve.

End plate classification

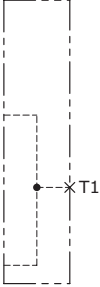
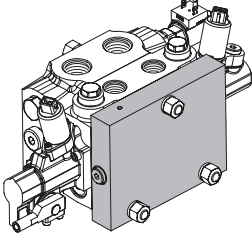
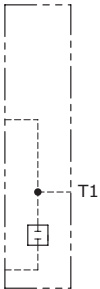
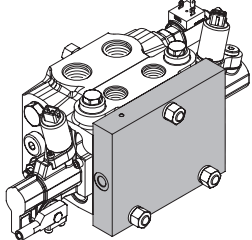
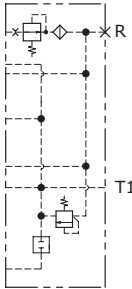
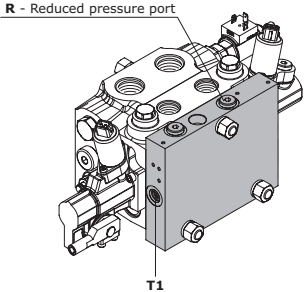
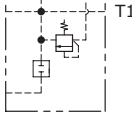
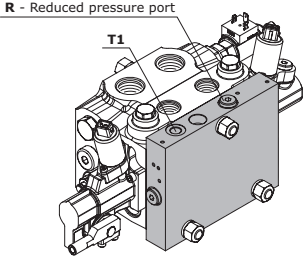
END PLATE FOR MECHANICAL LEVER ACTUATION AND HYDRAULIC ACTUATION			
code	schema	configuration	description
KZ10I			<p>End plate without RDP internal drain</p> <p>to be used with: H001-H004 HP05A-HP05C-HP05L</p>
KZ10E			<p>End plate without RDP external drain</p> <p>to be used with: H001-H004 HP05A-HP05C-HP05L</p>
END PLATE FOR ELECTROHYDRAULIC ACTUATION			
code	schema	configuration	description
KZ20EC			<p>End plate with RDP external drain</p> <p>to be used with: HP04-HP07</p>
KZ20EH			<p>End plate with RDP external-side drain</p> <p>to be used with: HP04-HP07</p>

NOTE:

Left inlet assembled valve with lever kit HP01, HP02, HP03 and HP04 on the last section accepts only KZ20EH and KZ10I end plate.

EX46 SPARE PARTS LIST

Inlet Section

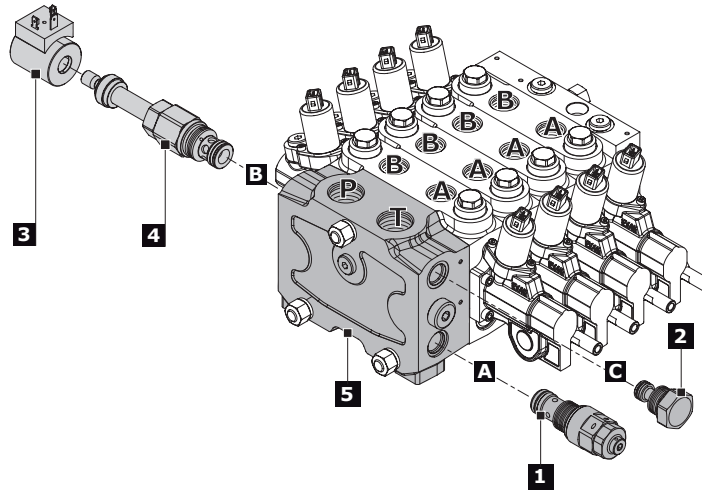

Ref.	Description	Order code	Q.ty	Code	Note
1	LS pressure relief valve	915028503	1	V1A	Setting range: 50-250 bar
		915028504	1	V2A	Setting range: 251-350 bar
	LS relief plug	430085034	1	V2A	
2	LS electric dump valve (*)	430059003	1	V10C	
		413150077	1	V11C	
3*	Coil kit	413171235	1	C12DI	DIN 43650 ISO 4400 - 12 Vdc
		413172432	1	C24DI	DIN 43650 ISO 4400 - 24 Vdc
		413171238	1	C12DE	DEUTSCH DT 4 - 12 Vdc
		413172440	1	C24DE	DEUTSCH DT 4 - 24 Vdc
		413171237	1	C12AJ	AMP JUNIOR - 12 Vdc
		413172433	1	C24AJ	AMP JUNIOR - 24 Vdc
4	Full flow pilot operated pressure relief valve	915078801	1	V3B	Setting range: 50-350 bar
		430488001	1	V4B	
		915049803	1	V7B	
5	Open centre inlet section	02A100001	1	KV G06	for fixed displacement pumps
		02A100002	1	KV U06	
	Closed centre inlet section	02A100011	1	JV G06	for variable displacement pumps
		02A100012	1	JV U06	

(*) = Coil kit must be ordered separately: see table "A" pg. 18

Post-Compensated Section

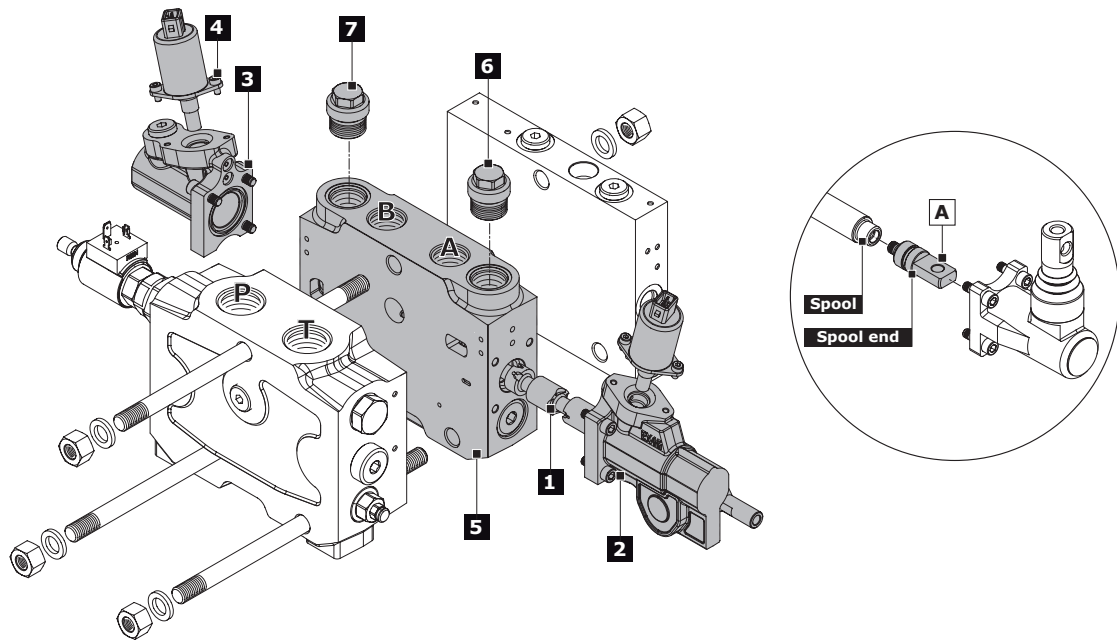

Ref.	Description	Order code	Q.ty	Code	Note
1	3 positions double-acting spool	4212A1023	1	W001C 4040	spool 40 l/min
		4212A1022	1	W001C 6060	spool 60 l/min
		4212A1021	1	W001C 9090	spool 90 l/min
		4212A1020	1	W001C 120120	spool 120 l/min
		4212A1019	1	W001C 150150	spool 150 l/min
		4212A1018	1	W001C 180180	spool 180 l/min
	3 positions double-acting partly open to tank	4212A1029	1	W002C 4040	spool 40 l/min
		4212A1028	1	W002C 6060	spool 60 l/min
		4212A1027	1	W002C 9090	spool 90 l/min
		4212A1026	1	W002C 120120	spool 120 l/min
		4212A1025	1	W002C 150150	spool 150 l/min
		4212A1024	1	W002C 180180	spool 180 l/min
A	Spool end kit	422501286	1		only for H001 and H004
		420314019	1		only for hydraulic actuation
		422501284	1		only for electrohydraulic actuation
2	Lever actuation kit	320305008	1	H001	
	Without lever actuation kit	3203A1001	1	H004	
	Hydraulic actuation (ports on the top)	3205A1100	1	HP05A	
	Hydraulic actuation (ports on the sides)	3205A1106	1	HP05C	BSP version
	Hydraulic actuation with stroke limiter	3205A1112	1	HP05L	
	Hydraulic actuation (ports on the top)	3205A1103	1	HP05A	
	Hydraulic actuation (ports on the sides)	3205A1109	1	HP05C	UNF version
	Hydraulic actuation with stroke limiter	3205A1115	1	HP05L	
	Lever actuation + electrohydraulic actuation	3225A1002	1	HP04	
	Lever actuation + electrohydraulic actuation with stroke limiter	3225A1003	1	HP04L	
	Without lever + electrohydraulic actuation	3225A1004	1	HP07	
Without lever + electrohydraulic actuation with stroke limiter	3225A1005	1	HP07L		

Ref.	Description	Order code	Q.ty	Code	Note
3	3 position spring centered spool	320705009	1	F001A	
		320705008	1	F001B	
	Detent in A and B	3208A1001	1	F002A	
	Proportional pneumatic control	321205004	1	F022A=F023A	BSP version
		321205009	1	F126A=F127A	NPT version
	Lever actuation + electrohydraulic actuation	3225A1102	1	FP04	only with HP04-HP07
	Without lever + electrohydraulic actuation with stroke limiter	3225A1103	1	FP07L	only with HP07L
Spool position indicator for electrohydraulic actuation	3225A1106	1	FP04S	only with HP04-HP07	
4	Coil-connector kit	430093100	2	B12AJ	AMP JUNIOR - 12 Vdc
		430093101	2	B24AJ	AMP JUNIOR - 12 Vdc
		430093102	2	B12DE	DEUTSCH DT 4 - 12 Vdc
		430093103	2	B24DE	DEUTSCH DT 4 - 24 Vdc
5	Post compensated section atandard with auxiliary valve	03A100001	1	RC1 G05	
	Post compensated section atandard without auxiliary valve	03A100003	1	RC2 G05	BSP version only for manual and hydraulic actuation
	Post compensated section atandard with auxiliary valve	03A100002	1	RC1 U05	
	Post compensated section atandard without auxiliary valve	03A100004	1	RC2 U05	
	Post compensated section standard with auxiliary valve	03A100101	1	RC1 G05	
	Post compensated section standard without auxiliary valve	03A100103	1	RC2 G05	BSP version only for electrohydraulic actuation
	Post compensated section atandard with auxiliary valve	03A100102	1	RC1 U05	
Post compensated section atandard without auxiliary valve	03A100104	1	RC2 U05		

Auxiliary valve

Post-compensated and Pre-compensated sections use the same auxiliary valves.

Ref.	Description	Order code	Q.ty	Code	Note
6	Anticavitation valve on port A	91508A101	1	02TF PA	
	Combined valve fixed setting on port A (*)	915A10100	1	03TF PA	fixed setting: 100 bar
		915A10150	1	03TF PA	fixed setting: 150 bar
		915A10200	1	03TF PA	fixed setting: 200 bar
		915A10250	1	03TF PA	fixed setting: 250 bar
		915A10300	1	03TF PA	fixed setting: 300 bar
		915A10350	1	03TF PA	fixed setting: 350 bar
Prearrangement for auxiliary valve on port A	4304A1001	1	05TF PA		
7	Anticavitation valve on port B	91508A101	1	02TF PB	
	Combined valve fixed setting on port B (*)	915A10100	1	03TF PB	fixed setting: 100 bar
		915A10150	1	03TF PB	fixed setting: 150 bar
		915A10200	1	03TF PB	fixed setting: 200 bar
		915A10250	1	03TF PB	fixed setting: 250 bar
		915A10300	1	03TF PB	fixed setting: 300 bar
		915A10350	1	03TF PB	fixed setting: 350 bar
Prearrangement for auxiliary valve on port B	4304A1001	1	05TF PB		

Outlet Section (End plate)

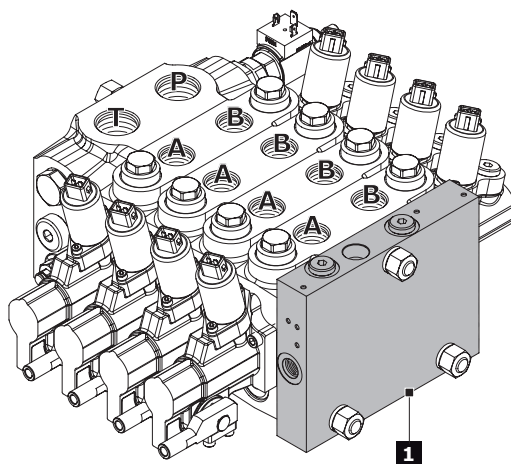

End plate for Mechanical and hydraulic actuation

Ref.	Description	Order code	Q.ty	Code	Note
1	End plate without RDP (internal drain)	3200A1004	1	KZ10I	BSP version
		3200A1008	1		UNF version
	End plate without RDP (external drain)	3200A1005	1	KZ10E	BSP version
		3200A1009	1		UNF version

End plate for electrohydraulic actuation

Ref.	Description	Order code	Q.ty	Code	Note
1	End plate with RDP (external drain)	3200A1003	1	KZ20EC	BSP version
		3200A1012	1		UNF version
	End plate with RDP (external-side drain)	3200A1006	1	KZ20EH	BSP version
		3200A1010	1		UNF version

Gasket kits

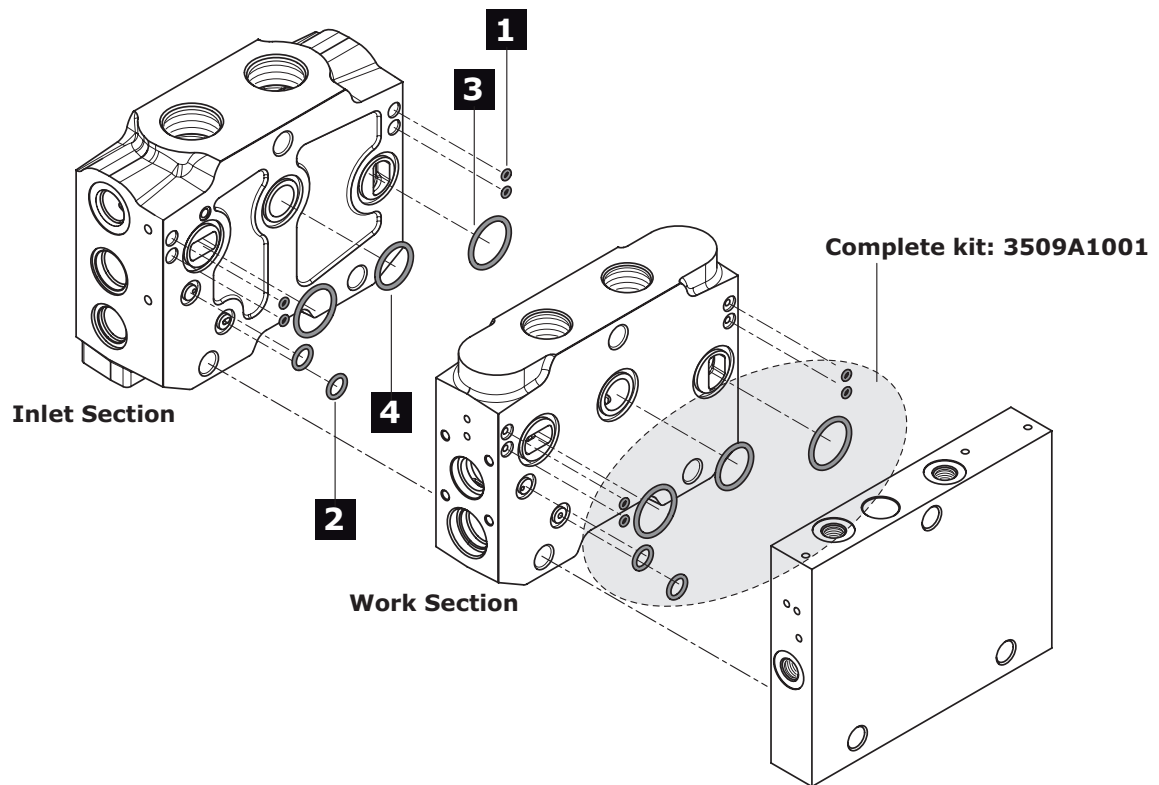

Ref.	Order Code	Description	Q.ty
1	412020118	O.R. 90SH 3.10 x 1,6 (N270R050)	4
2	412020303	O.R. 90SH 10 x 2.20 (6-532)	2
3	412020605	O.R. 90SH 25.07 x 2.62 (2-120)	2
4	412020610	O.R. 90SH 21.89 x 2.62 (2-118)	1
Order code complete Gasket kit: 3509A1001			

INSTALLATION AND MAINTENANCE INSTRUCTIONS

Guidelines

- Never use the Control Valve at a pressure exceeding the rated pressure; if not, there is the possibility of leakage in the Control Valve;
- Use the Control Valve within the rated flow; if not there might be malfunction or a deterioration in heat balance. If it is unavoidable to use the Control Valve at a level exceeding the rated flow, carry out various confirmatory tests and use it within the verified range. If the Control Valve is used under a condition beyond the verified range, we shall not be responsible for any accidents occurred as a result of the use.
- Using low-cleanliness hydraulic fluid might cause seal failure or damage to the seal part, resulting in operation failure, or operation mistake of the machine; the customer is requested to check the cleanliness of the hydraulic fluid without fail.

Storage

Do not store the HC product in:

- Places where it might be damaged;
- Very hot/humid areas;
- Where it could get wet;
- Where it could come into contact with organic solvents, acids, alkalis and/or dangerous gases;
- In places subject to sudden, significant changes in temperature;
- only remove the packaging when you have decided to assemble the product.



Warning

- Hydrocontrol is not responsible for any damages due to a storage not in compliance with our prescriptions;
- For any doubts, please contact our aftersales department.

Installation procedures

On receiving the Hydrocontrol product make sure you:

- Check if there are some sign of damage of the packaging;
- Check that the dimensions of the product seat are compatible with those of the product itself;
- Check that assembly seat is compatible with the dimensions of the part and that it has been prepared for part set-up (connection hoses ready etc.);
- Remove the plastic caps that protect the service ports and be careful not to introduce any dirt or foreign matters inside the control valve as this could damage it;
- Mount the control valve securely to a flat surface (recommended 3 point fixing); at the time do not use a hammer to positioning by hitting; any distortion in assembly can result in spool sticking and poor control;
- Clean piping materials sufficiently before use;
- Prevent the port openings from being entered with dust or foreign matters;
- Double check that hoses are correctly connected following prescription and indication of hydraulic schema, especially:
 - (in case of EH control) be sure that drain line is directly connected to tank (avoid any back pressure)
 - (in case of variable displacement system) be sure that LS signal line is correctly connected to the pump regulator.
- tighten the port connectors surely with the recommended fastening torques (Nm) as shown in the following table;
- If possible, install the valve in a protected environment, avoiding direct exposure to weathering, water, salt or any other corrosion substances

Fittings tightening torque (Nm)

thread type	port P	Port A - B	Port T
BSP (ISO - 228)	G 3/4	G 1/2	G 3/4
with rubber sealing (DIN 3869)	70	60	70
with copper or steel and rubber washer	70	60	70
UN-UNF (ISO - 725)	1"1/16 - 12 UNF	7/8" - 14 UNF	1"1/16 - 12 UNF
with O.R.	95	90	95

INSTALLATION AND MAINTENANCE INSTRUCTIONS



Warning

- Falling or hitting the Control Valve might bend the Spool so as to cause an accident due to an operation failure;
- If the Control Valve is mounted in a uneven surface, the Control Valve Body might be deformed, which results on a malfunction or external leakage;
- If there are foreign matters in each port, the Control Valve operation might fail so as to cause an accident;
- Do not tighten fittings with torque more than the recommended value; If not there might be strains or damage to Control Valve so as to cause a serious accident;
- If the piping are not connected to the correspondent ports, unintentional movements might cause a serious accident;
- Hydrocontrol is not responsible for any damages due to an installation procedure not in compliance with our prescriptions;
- For any doubts, please contact our aftersales department.

Handling Precautions

When the Control Valve is handled, ensure:

- that you do not drop, hit or damage the product;
- that you do not hold the pilot cover or return spring cap of the spool or accessory valves such as main relief valves and anti-shock relief valves

Handling Precautions

Disassembly and assembly should be carried out by Hydrocontrol technicians. If the Control Valve doesn't work in the adequate way, we advise you to contact our aftersales department. However if the disassembly and assembly operations are strictly unavoidable, you must observe the following prescriptions and charge the carrying out of the operations to technicians high qualified in hydraulic field.

- The Control Valve reaches high temperature after operating the machine; start the work only after checking that the temperature is low;
- The valve can hold high internal pressure; release the inside pressure and ensure all machine actuators are in a rest position before removing the piping. In any case safely and carefully unscrew connections and fittings. If not, there might be a fall of attachments or high-temperature hydraulic fluid jet. Remind to wear the safety equipment and goggles;
- Pay attention in removing electrical connectors;
- Since hydraulic devices are all machined precisely with very accurate clearances, carry out the disassembly adassembly work at a clean place;
- Make sure to prevent the device form being entered with dust, sand and the like;
- Before removing the pipes, attach suitable indications on them to be able to locate their positions late. It is also advisable to label dismantled parts and write down their original location;
- Before disassembly work, get the assembly instructions by requiring to our aftersales department and prepare all the material needed for the task;
- To disassemble and assemble the valve observe strictly our mounting instructions;
- Since there is the possibility of rust when the disassembled parts are left, apply anticorrosive oil to the parts and seal them;
- If it is unavoidable to dismount spring kit from the spool, ensure to clamp the spool through plastic or aluminum devices;
- Before remounting the Control Valve on the operating machine, ensure that the Control Valve has not been affected by carrying out various hydraulic tests (e.g. Relief Valve setting, Leak test..);
- Before reassembling electrical connectors, verify their integrity and check if they are dry



Warning

- Always bear in mind that "all workers must act responsibly to ensure their own health and safety"; use of personal protection equipment is therefore essential. All the disassembly and assembly operations must observe strictly the procedures listed in the Hydrocontrol Mounting Instruction.
- Hydrocontrol is not responsible for any damages due to disassembly and assembly procedures not in compliance with our prescriptions.
- For any doubts, please contact our aftersales department.

General clamping torque

The following table provides the main tightening torques of the distributor HC-EX46; are highlighted in 3 separate drawings depicting the inlet section, the working section and the outlet section.

Inlet Section

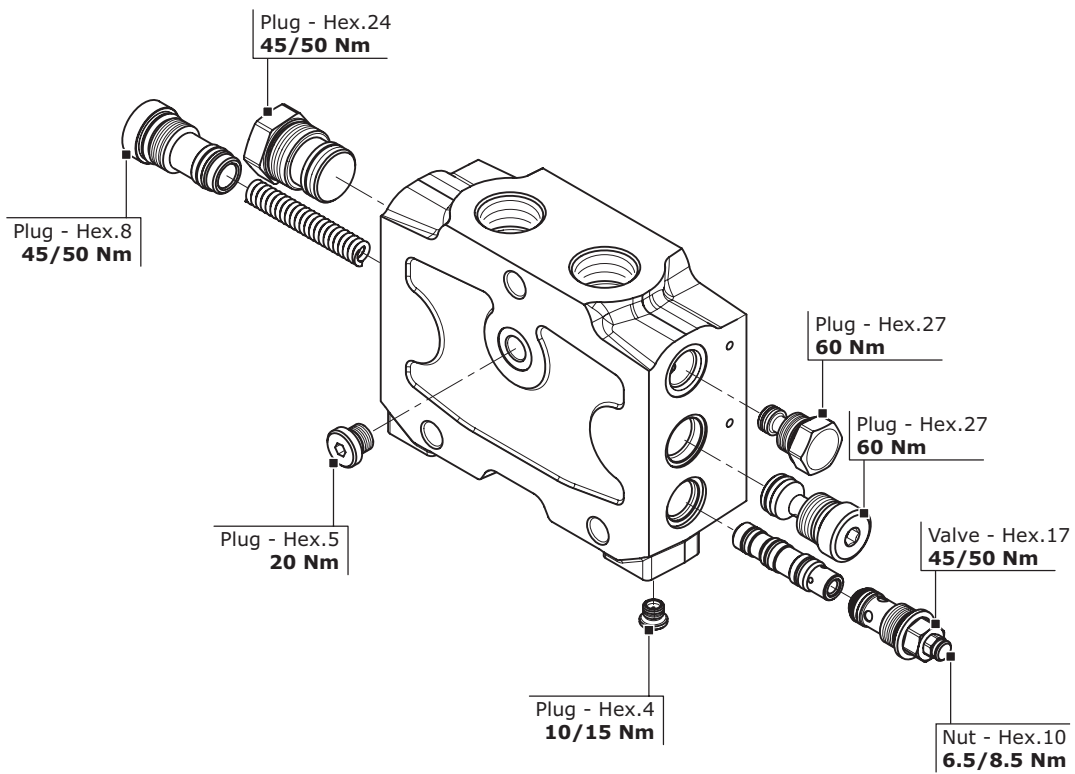

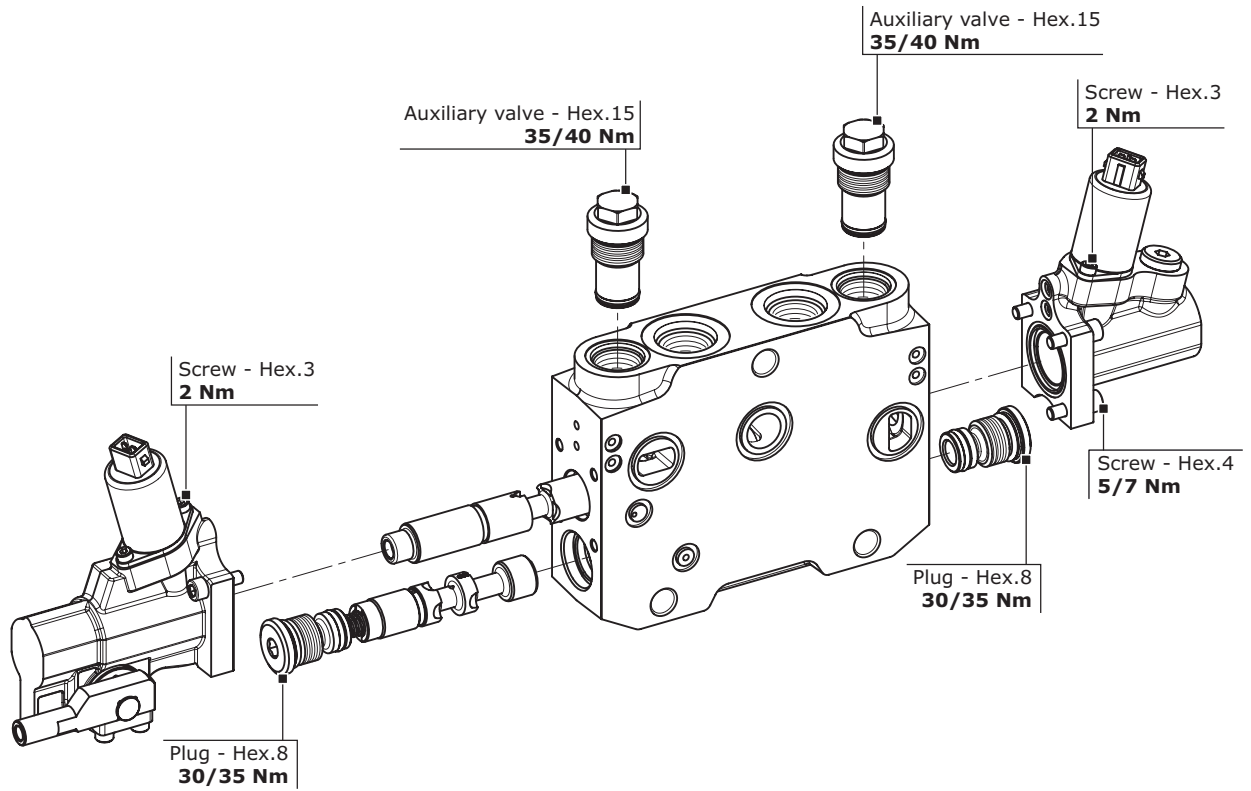
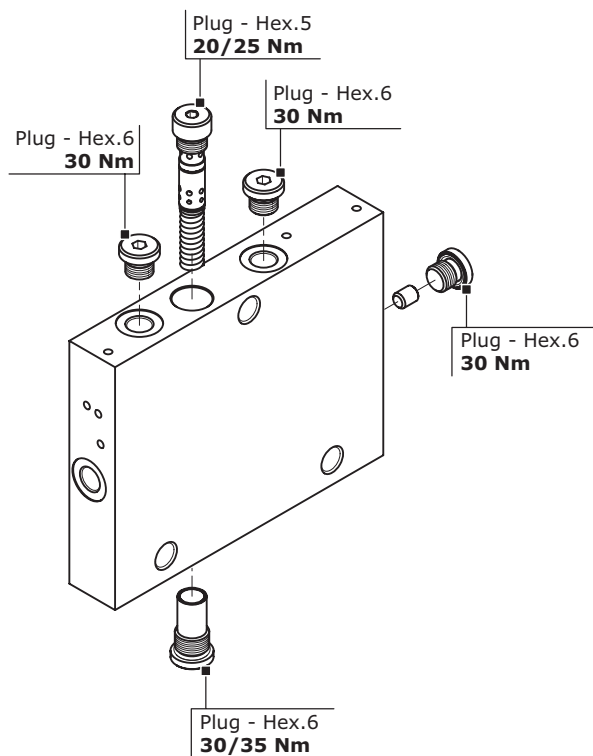
Work Section**Outlet Section**

Dimensions - Thread codes

The connection ports size is indicated by an ordering code common for all Hydrocontrol products. Following table shows all available connections.

METRIC THREAD (ISO 9974-1)

Type	M18x1,5	M22x1,5	M27x2
Code	M01	M02	M03

BSP THREAD (ISO 1179-1)

Type	1/4"	3/8"	1/2"	3/4"	1"	1 1/4"	1 1/2"	2"
Code	G02	G03	G04	G05	G06	G07	G08	G09

UN / UNF THREAD (ISO 11926-1)

Type	9/16" 18 UNF SAE6	3/4" 16 UNF SAE8	7/8" 14 UNF SAE10	1 1/16" 12 UNF SAE12	1 5/16" 12 UNF SAE16	1 5/8" 12 UNF SAE20
Code	U02	U03	U04	U05	U06	U07

Dimensions - SAE Flange codes

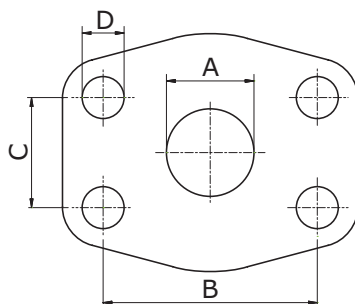

SAE / 3000 FLANGE (ISO 6162-1)

Type	3/4" (MA)	3/4" (UNC)	1" (MA)	1" (UNC)	1 1/4" (MA)	1 1/4" (UNC)	1 1/2" (MA)	1 1/2" (UNC)	2" (MA)	2" (UNC)	3" (MA)	3" (UNC)
Code	S03	S04	S05	S06	S07	S08	S09	S10	S11	S12	S15	S16
A	19	19	25	25	32	32	38	38	51	51	76	76
B	47,6	47,6	52,4	52,4	58,7	58,7	69,9	69,9	77,8	77,8	106,4	106,4
C	22,3	22,3	26,2	26,2	30,2	30,2	35,7	35,7	42,9	42,9	61,9	61,9
D	M10	3/8-16	M10	3/8-16	M10	7/16-14	M12	1/2-13	M12	1/2-13	M16	5/8-11

SAE / 6000 FLANGE (ISO 6162-2)

Type	3/4" (MA)	3/4" (UNC)	1" (MA)	1" (UNC)	1 1/4" (MA)	1 1/4" (UNC)	1 1/2" (MA)	1 1/2" (UNC)
Code	S33	S34	S35	S36	S37	S38	S39	S40
A	19	19	25	25	32	32	38	38
B	50,8	50,8	57,2	57,2	66,6	66,6	79,3	79,3
C	23,8	23,8	27,8	27,8	31,8	31,8	36,5	36,5
D	M10	3/8-16	M12	7/16-14	M14	1/2-13	M16	5/8-11

GENERAL CONDITIONS AND PATENTS

Product identification

All Hydrocontrol products have an identifying plate placed in specific position.



Serial number

Serial number:
It univocally identifies the physical valve: this provides an easy way to find all sales and production details.

Product code

Product code:
It is a number univocally identifying the configuration and pressure settings of a valve.

Introduction

These general conditions apply to all general supplies from Hydrocontrol s.p.a., after receiving orders from the Customer. Should commercial terms such as EXW, DDP, etc be mentioned, of course the Incoterms of the International Chamber of Commerce must be referred to, according to the test existing when the general supply conditions are agreed on.

Management of orders

No Customer's order is binding to Hydrocontrol s.p.a. if Hydrocontrol s.p.a. has not confirmed the order in writing. Hydrocontrol s.p.a. commits to supplying the orders in compliance with the order confirmation that has been issued. Any disagreement with the content of the order confirmation must be communicated in writing to Hydrocontrol s.p.a. within and no later than 5 days from the delivery of the order confirmation. The Customer commits to paying for the goods supplied by Hydrocontrol s.p.a., according to the prices indicated on the order confirmation.

Payment conditions

The Parties agree on the payment terms at the beginning of the supply. The terms will be indicated on the order confirmation. Should the Customer be late with the payments, Hydrocontrol S.p.a. will be entitled to require the payment of interests on arrears based on the exiting Prime Rate increased by 2%. Should there be any payment delay, Hydrocontrol s.p.a. will be entitled not to process the Customer's purchase order, even if it has already been confirmed.

Delivery and shipment

The goods are always supplied Ex Works, even when Hydrocontrol s.p.a. agrees with the Customer that the shipment, or a part of it, will be arranged by Hydrocontrol s.p.a. It is agreed that the Customer will bear the risk of goods deterioration or damaging from the moment the goods are handed by Hydrocontrol s.p.a. to the first carrier.

Product characteristics

Hydrocontrol s.p.a. commits to supplying good quality products, compliant with the technical specifications declared on the technical tables and on the catalogue. Hydrocontrol s.p.a, even without notice, at its own discretion, reserves the right to modify the products as necessary, without these changes altering the main characteristics of the products.

Claims

Any claims about defects on delivered products (just as an example: claims about the packaging, the number, the quantity or the external product characteristics) will have to be notified to Hydrocontrol s.p.a. in writing, within and no later than 7 days from reception of the goods, otherwise the claims will be considered as null and void. Occult defects (the defects of the goods that cannot be spotted with a careful control of the goods received by the Customer), will have to be notified in writing to Hydrocontrol s.p.a. within 7 days from the discovery of the defect, and anyhow no later than 12 months from the delivery of the goods, otherwise the claim will be considered as null and void. Even in case of claim or objection, the Customer will never be entitled to suspend or delay the payments to Hydrocontrol s.p.a. for the products subject to claim or objection nor for any other supply.

GENERAL CONDITIONS AND PATENTS**Warranty**

Should the products supplied by Hydrocontrol not be compliant or have the required quality and should this defect be due to Hydrocontrol, Hydrocontrol s.p.a. commits, at its choice, to replace or repair the faulty products, as long as the defect or lack of compliance is notified to Hydrocontrol s.p.a. in writing, as specified at point 6, within and no later than 12 months from product delivery. On the products that have been fixed or replaced in accordance with what specified above, the above-mentioned warranty applies. The 12 month duration starts from the date of repair or replacement. In case of defects, lack of quality or in case of lack of compliance for the supplied products, with the exception of fraud or serious offence, Hydrocontrol s.p.a. only commits to repairing or replacing the faulty products, according to what specified above. This warranty replaces any other Supplier's warranty or liability established by the law. This warranty excludes any other liability contractual or extra-contractual by Hydrocontrol s.p.a. on the products supplied by Hydrocontrol (as a mere example: damage refund, loss of profit, product recall campaign, etc). Hydrocontrol s.p.a. has signed a product civil liability police, with a suitable maximum coverage.

Ownership retention

The products supplied by Hydrocontrol s.p.a. will be owned by the latter until Hydrocontrol receives the complete payment for the supplied goods.

Obligation confidentiality

Hydrocontrol s.p.a. commits to not disclosing the technical and commercial information it receives from the Customer, unless this information has already been publicly disclosed.

Patents

The Customer is not allowed to use the provided Products, or a part of them, their descriptions or drawings protected or not protected by Patent or registered trademark in order to design or make similar products, unless Hydrocontrol s.p.a. previously issues its written authorization. Should Hydrocontrol s.p.a. give its written authorization, all patents, trademarks, registered designs, copyrights and intellectual property rights related or connected to the Products provided by Hydrocontrol s.p.a. will stay Hydrocontrol's property. The Customer commits to respecting the highest confidentiality.

Applicable law and court of jurisdiction

Hydrocontrol s.p.a.'s supplies are regulated by these General Supply Conditions and, for anything not defined here, by the Italian law. Any controversy related, generated or connected to the supply of Products by Hydrocontrol s.p.a., where Hydrocontrol s.p.a. is involved, will be exclusively dealt with by the Court of Bologna.