

# HC-D16 Series

Sectional Directional Control Valve

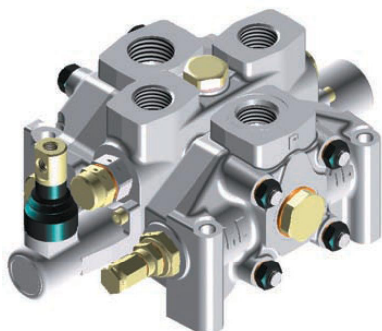

## GENERAL SPECIFICATIONS



### Universal products and solutions

HC-D16 control valve belongs to the wide range of Hydrocontrol S.p.A. modular sectional valves and is capable of working with a maximum flow of 150 litres/min. at an operating pressure of 350 bar.

Numerous integrated valve features in addition to countless configuration options make HC-D16 highly flexible and easily adaptable to the widest applications range.

Sections are equipped with auxiliary valves and a wide variety of interchangeable spools.

### Standard working conditions

- FLOW RATE ..... 40 GPM
- PRESSURE RATE ..... 5000 PSI
- MAX PRESSURE ON (T) ..... 290 PSI
- OPERATING TEMPERATURE ..... -25°C / +80°C
- KINEMATIC VISCOSITY ..... from 10 to 460 mm<sup>2</sup>/s
- CONTAMINATION LEVEL ..... 19/16 ISO 4406
- FILTRATION LEVEL .....  $\beta_{10} > 75$

### Technical specifications

- WORKING SECTION NUMBER ..... 1 - 12
- SPOOL STROKE ..... 0,28 + 0,28 in
- SPOOLS PITCH ..... 1,8 in

### Fluid compatibility

TYPE OF FLUID (Oil and Solution)	TEMP. (C°)		GASKET	
	min	max	NBR	VITON(*)
Mineral oil HPL (DIN 51524)	-25	+80	•	•
Oil in water emulsion HFA(*)	+5	+55	•	•
Water in oil emulsion HFB(*)	+5	+55	•	•
Polyglycol-based aqueous sol. HFC(*)	-25	+60	•	
Ester of phosphoric acid HCD(*)	-20	+150		•

(\*) : for this application, please contact our technical sales office.

NBR : nitrile rubber compatible with mineral-bases oils ASTM 1

VITON : fluorinated elastomer for use at high temperature, compatible with fluids ASTM 1 and ASTM 3

### Unit of measure - Conversion factors

Systems / Unit	METRIC	BSP
LENGTH	1 mm = 0,0394 in	1 in = 25,4 mm
MASS	1 kg = 2,205 lb	1 lb = 0,4536 kg
FORCE	1 Nm = 0,1020 kgf	1 kgf = 9,8067 Nm
VOLUME	1 l = 0,2200 gal UK	1 gal UK = 4,546 l
	1 i = 0,2642 gal US	1 gal US = 3,785 l
PRESSURE	1 bar = 100000 Pa	1 Pa = 0,00001 bar
	1 bar = 14,5 psi	1 psi = 0.0689 bar



# HC-D16 Series

Sectional Directional Control Valve



## ORDER MODALITY

### Assembly specifications

Tie rod kit allows the correct assembling of HC-D16. Tie rods length depends on number of sections.

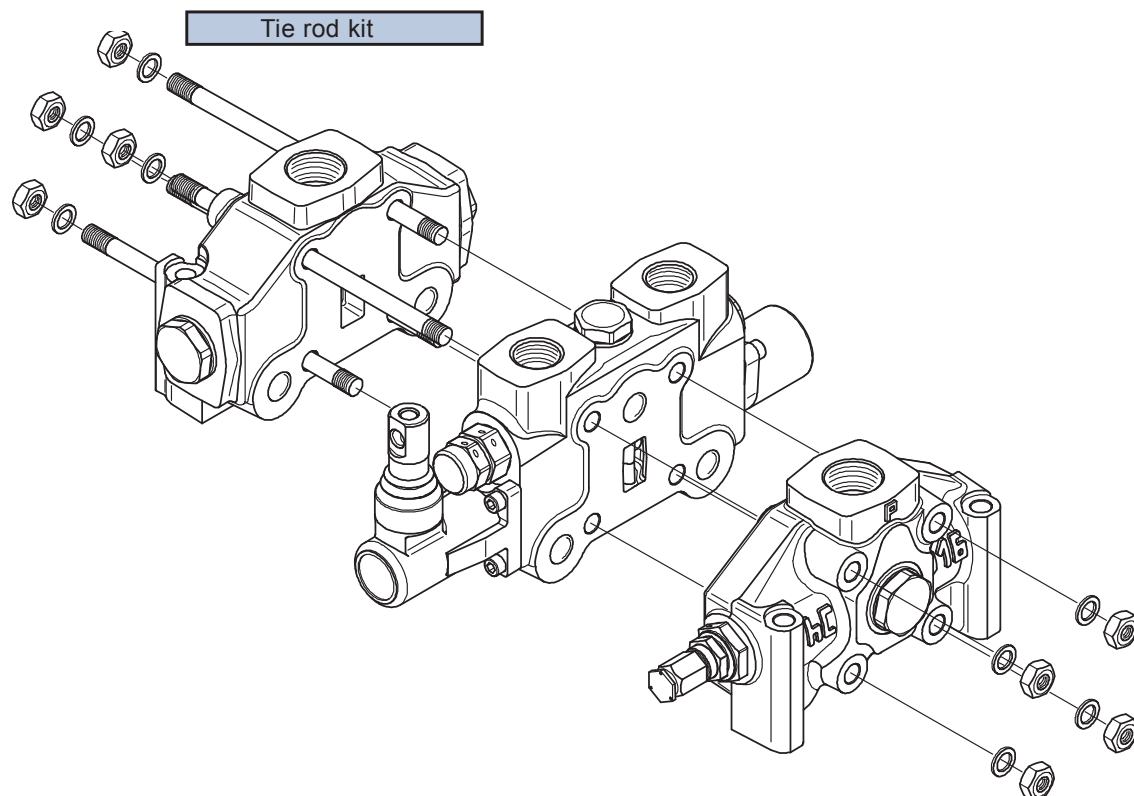

**TIE ROD LENGTH**

Type	/1	/2	/3	/4	/5	/6	/7	/8	/9	/10	/11	/12
mm	200	246	292	338	384	430	476	522	568	614	660	706
in	7,9	9,7	11,5	13,3	15,1	16,9	18,7	20,5	22,3	24,1	25,9	27,8

Tie-rod clamping torque	5,1 Kgf
	50 Nm

**NOTE:** each valve is assembled with N° 4 tie rod kits including a tie rod, two nuts and two washers.

# HC-D16 Series

Sectional Directional Control Valve



## DIMENSIONS

### Standard thread

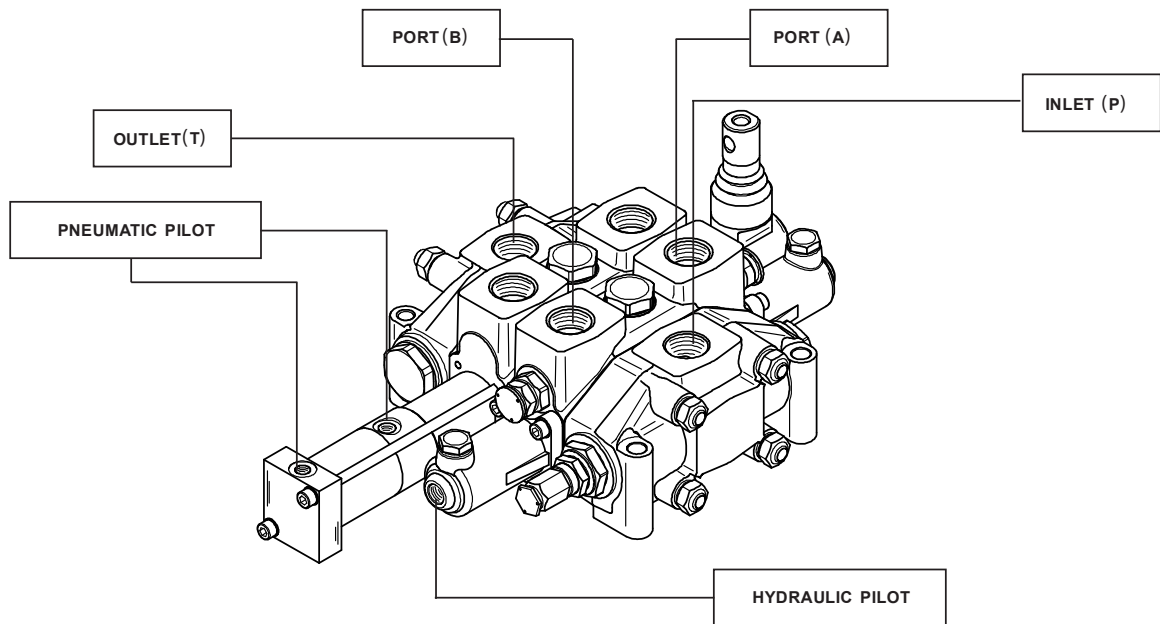

PORTS	thread (BSP) ISO-228	thread (SAE UN-UNF) ISO-725
Inlet P	G 3/4	1-1/16" - 12 UN
Ports A - B	G 3/4	1-1/16" - 12 UN
Outlet T	G 1	1-5/16" - 12 UN
Carry-over HPCO	G 1	1-5/16" - 12 UN

PORTS	thread (BSP) ISO-228
Hydraulic pilot	G 1/4
Pneumatic pilot	G 1/8

### Ordering codes

3/4" BSP

**G05**

1" BSP

**G06**

1" 1/16-12 UN

**U05**

1" 5/16-12 UN

**U06**



# HC-D16 Series

Sectional Directional Control Valve



## HYDRAULIC SPECIFICATIONS

### Parallel circuit

When the spool is operated it intercepts the switch gallery by diverting the flow of oil to service port A or B. If two or more spools are actuated at the same time, the oil will power the service port that has the lower load by selecting the path with the least resistance; by throttling the spools, the flow of oil can be divided between two or more service ports.

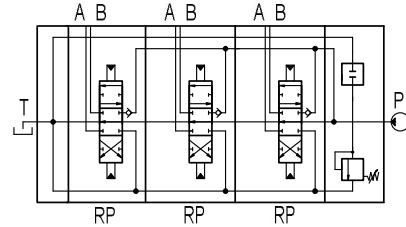

### Series circuit

When the spool is operated it intercepts the switch gallery by diverting the flow of oil to service port A or B. The oil that flows back from the actuator is carried to the switch gallery thus making it available to the service ports downstream from the series section. The pressure drop downstream is added to the pressure drop of the section itself.

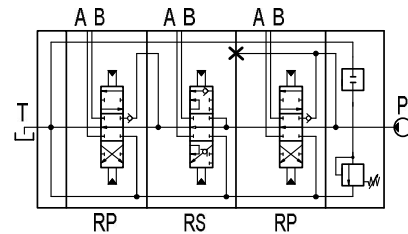

### Carry-over connection (HPCO)

This option, available on all HC-D16, allows the monoblock to feed a second valve, by extending the free flow channel. In this configuration, the valve needs a separated port for the connection to tank.

**IT IS POSSIBLE TO TRANSFORM SECTIONAL VALVE FROM STANDARD TO HPCO VERSION JUST BY ORDERING THE APPROPRIATE CONIC PLUG 3/8" x 15 (CODE 413010207)**

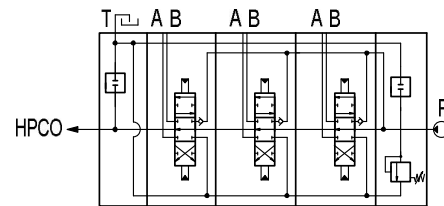

## OUTLET SECTION WITH HPCO VERSION

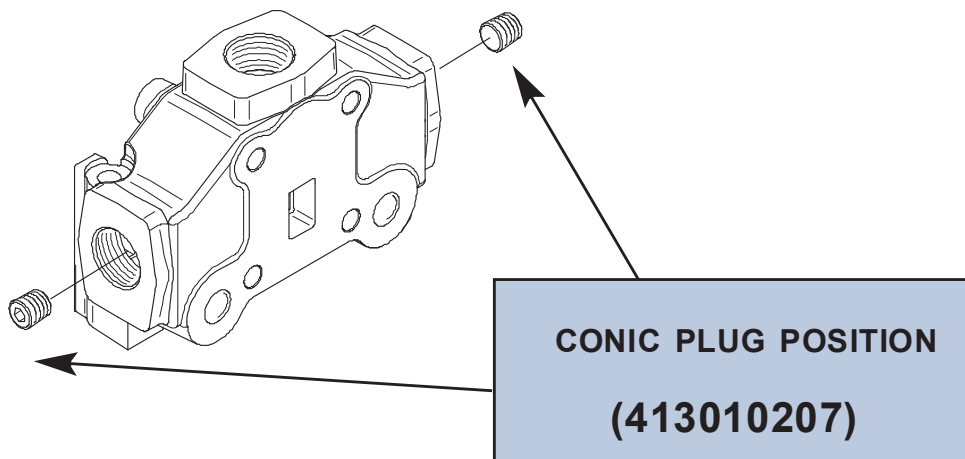

# HC-D16 Series

Sectional Directional Control Valve



## TYPICAL CURVES

### Pressure drop (P - T)

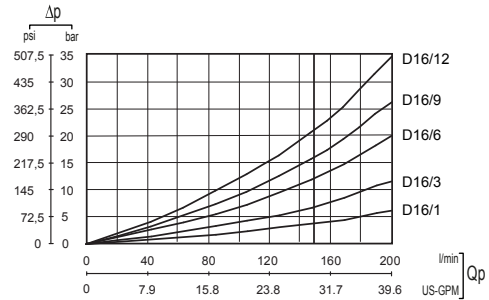
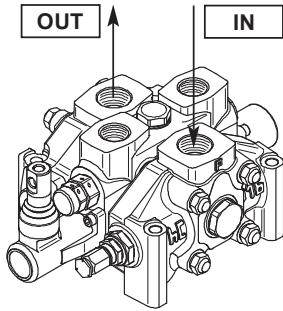

### Pressure drop (P - A/B)

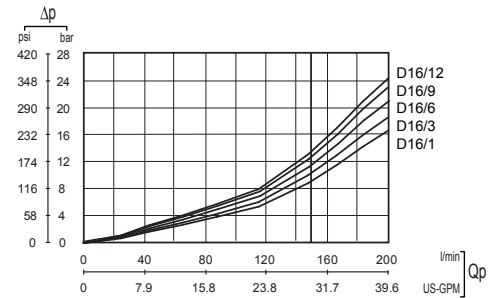
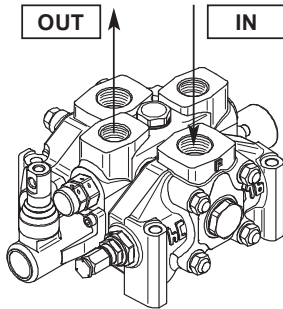

### Pressure drop (A/B - T)

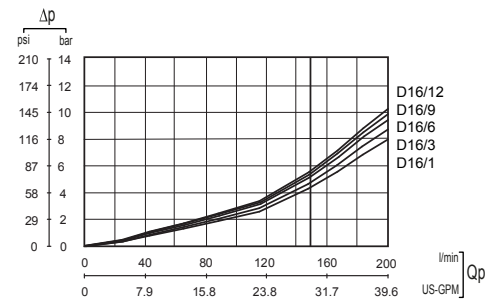
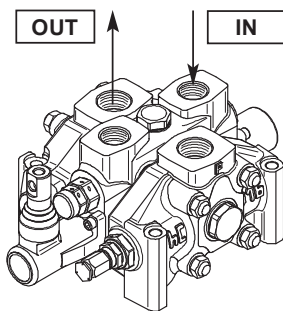

### Pilot operated relief valve curve

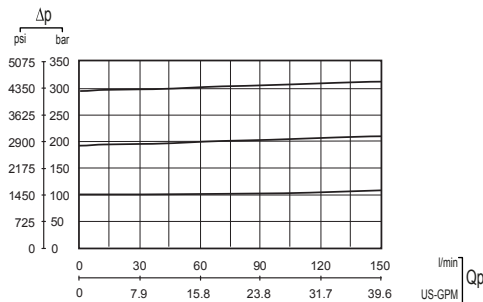

#### Setting range

- (A) = 3 / 40 (bar)
- (B) = 41 / 180 (bar)
- (C) = 181 / 250 (bar)
- (D) = 251 / 350 (bar)

**NOTE:** indicated values have been tested with standard sectional valve and W001A spools.

# HC-D16 Series

Sectional Directional Control Valve



## TYPICAL CURVES

Main anticavitation check valve curve

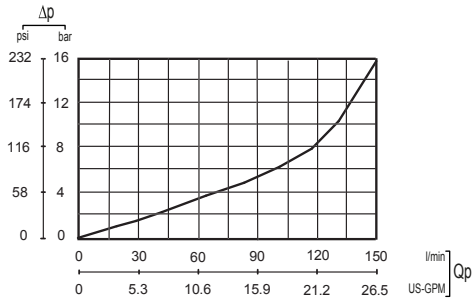

Anticavitation check valve curve

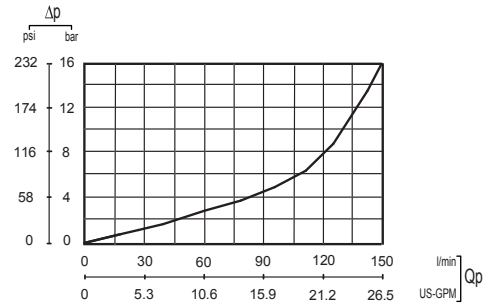

Antishock valve curve

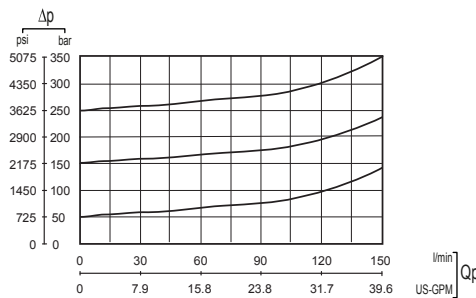

**Setting range**

- (A) = 0/150 - at full flow  
0-A / 120-A - at min. flow
- (B) = 151/230 - at full flow  
121-A / 200 - at min. flow
- (C) = 231/280 - at full flow  
201-A / 250-A - at min. flow
- (D) = 281/350 - at full flow  
251-A / 350-A - at min. flow

Combined valve curve

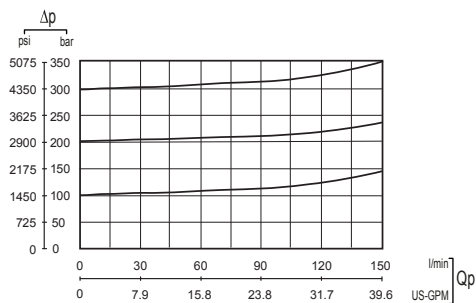

**Setting range**

- (A) = 30/95 - at full flow  
30-A / 65-A - at min. flow
- (B) = 96/150 - at full flow  
66-A / 120 - at min. flow
- (C) = 151/260 - at full flow  
121-A / 230-A - at min. flow
- (D) = 261/350 - at full flow  
231-A / 350-A - at min. flow

Hydraulic pilot control curve

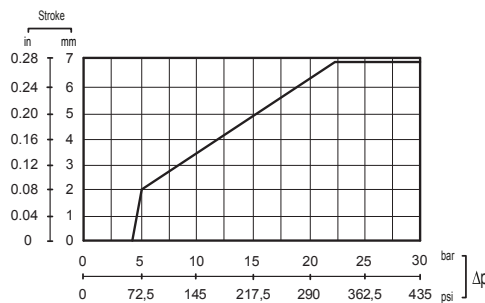

**NOTE:** the graphic shows the spool stroke as a function of the operating pressure.

# HC-D16 Series

Sectional Directional Control Valve



## INLET SECTION

### Order example

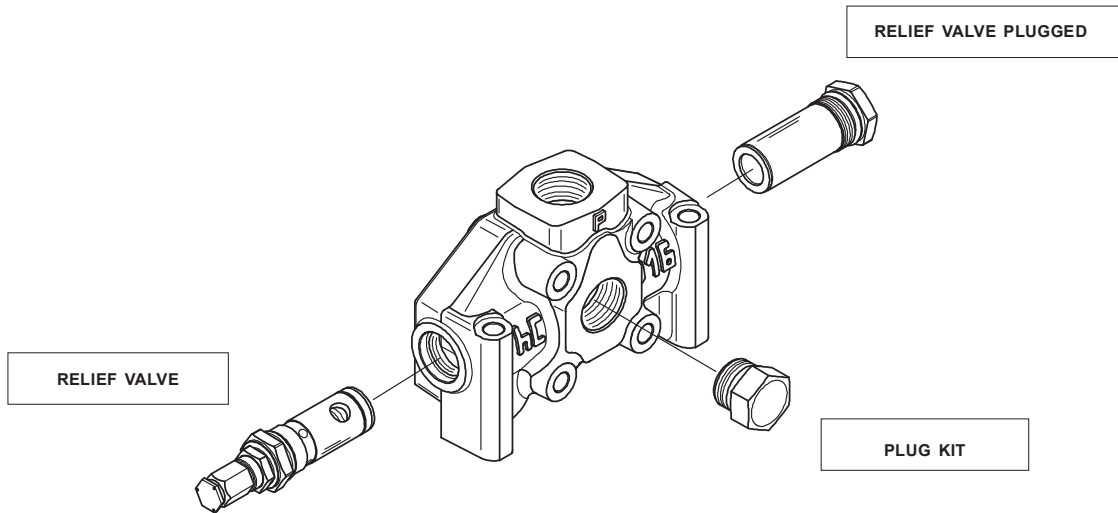

- IR** inlet side
- 009** valve arrangement
- (150)** setting direct acting pressure valve
- A G05** inlet position and available thread type

### Inlet side

HYDRAULIC DIAGRAM	LAYOUT	DESCRIPTION + CODE
		<p><b>LEFT INLET SECTION</b></p> <p><b>IL</b></p>
		<p><b>RIGHT INLET SECTION</b></p> <p><b>IR</b></p>

# HC-D16 Series

Sectional Directional Control Valve



## INLET ARRANGEMENT

### Valves identification

TYPE	DESIGN	DIAGRAM	DESCRIPTION	TYPE	DESIGN	DIAGRAM	DESCRIPTION
2			Pilot operated pressure relief valve	7			Solenoid dump valve (12 Vdc)
3			Relief valve plugged	8			Solenoid dump valve (24 Vdc)
4			Main anticavitation check valve	9			Solenoid dump valve (26 Vdc)
5			2 stage pilot operated relief valve	11			Plug with pressure gauge connection
6			Externally piloted valve				

### Valve arrangement

Example **009 = 2A-3B**

Pressure relief valve in port A side

Plug replaces pressure relief valve in port B side

The code identifies: with a number, the type of valve; with a letter, its position on the inlet section.

(A) = spool action side

(B) = spool return action side

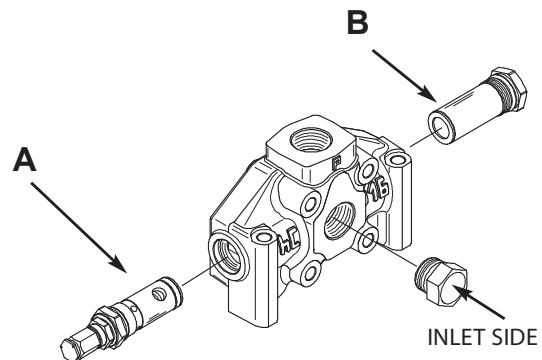

# HC-D16 Series

Sectional Directional Control Valve



## INLET ARRANGEMENT

### Valves combination

<b>009</b>	<b>010</b>	<b>011</b>	<b>012</b>	<b>013</b>	<b>014</b>	<b>016</b>	<b>018</b>	<b>019</b>	<b>020</b>	<b>021</b>	<b>022</b>	<b>023</b>	<b>024</b>
2A-3B	2A-4B	2A-6B	2A-7B	2A-8B	2A-9B	2A-11B	3A-2B	3A-3B	3A-4B	3A-5B	3A-6B	3A-7B	3A-8B
<b>025</b>	<b>027</b>	<b>029</b>	<b>030</b>	<b>031</b>	<b>032</b>	<b>033</b>	<b>034</b>	<b>035</b>	<b>037</b>	<b>038</b>	<b>039</b>	<b>040</b>	<b>041</b>
3A-9B	3A-11B	4A-2B	4A-3B	4A-5B	4A-6B	4A-7B	4A-8B	4A-9B	4A-11B	5A-3B	5A-4B	5A-6B	5A-7B
<b>042</b>	<b>043</b>	<b>045</b>	<b>047</b>	<b>048</b>	<b>049</b>	<b>050</b>	<b>052</b>	<b>054</b>	<b>055</b>	<b>056</b>	<b>057</b>	<b>059</b>	<b>061</b>
5A-8B	5A-3B	5A-11B	6A-2B	6A-3B	6A-4B	6A-5B	6A-11B	7A-2B	7A-3B	7A-4B	7A-5B	7A-11B	8A-2B
<b>062</b>	<b>063</b>	<b>064</b>	<b>066</b>	<b>068</b>	<b>069</b>	<b>070</b>	<b>071</b>	<b>073</b>	<b>085</b>	<b>086</b>	<b>087</b>	<b>088</b>	<b>089</b>
8A-3B	8A-4B	8A-5B	8A-11B	9A-2B	9A-3B	9A-4B	9A-5B	9A-11B	11A-2B	11A-3B	11A-4B	11A-5B	11A-6B
<b>090</b>	<b>091</b>	<b>092</b>											
11A-7B	11A-8B	11A-9B											

### Inlet and thread available

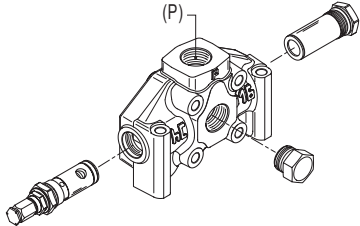
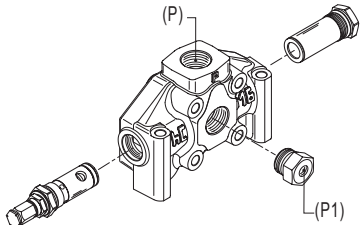
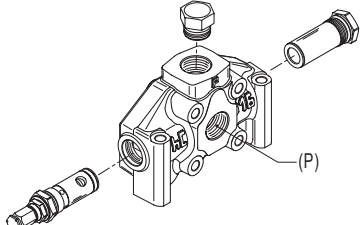
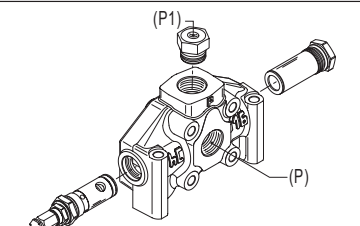
<b>A</b>	Upper inlet	<b>G05</b>	<b>U05</b>	
<b>B</b>	Upper inlet - P1 with pressure-gauge connection 1/4" BSP	<b>G05</b>	<b>U05</b>	
<b>C</b>	Central side inlet	<b>G05</b>	<b>U05</b>	
<b>D</b>	Central side inlet - P1 with pressure-gauge connection 1/4" BSP	<b>G05</b>	<b>U05</b>	

# HC-D16 Series

Sectional Directional Control Valve



## WORK SECTION

Order example:

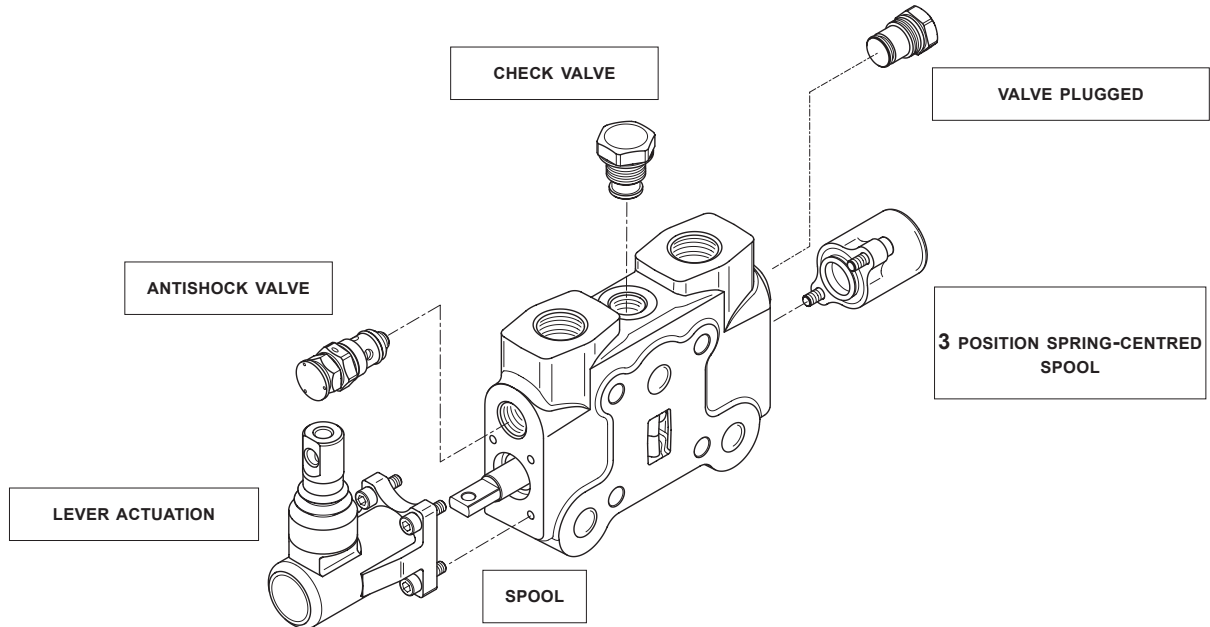

- W001A** spool type
- H001** spool actuation type
- F001A** spool return action type
- RP G05** type and thread section
- 01PA** auxiliary valve (port A)
- (120)** setting (port A)
- 05PB** auxiliary valve (port B)

## Spools identification

HYDRAULIC SCHEMATIC	CIRCUIT DESCRIPTION	CODE
	3 positions double-acting	<b>W001</b>
	3 positions double-acting A and B to tank	<b>W002</b>
	3 positions double-acting A to tank B blocked	<b>W003</b>
	3 positions double-acting A blocked B to tank	<b>W004</b>

# HC-D16 Series

Sectional Directional Control Valve



## SPOOL TYPE

### Spools identification

	3 positions single-acting on A	<b>W005</b>
	3 positions single-acting on B	<b>W006</b>
	3 positions double-acting with anticavitation valves	<b>W009</b>
	3 positions double-acting switch port closed (A and B blocked)	<b>W010</b>
	3 positions double-acting switch port closed (A and B to tank)	<b>W011</b>
	4 positions double-acting with float in the 4 <sup>th</sup> position	<b>W012</b>
	3 positions double-acting regenerative	<b>W013</b>
	3 positions double-acting series	<b>W015</b>
	3 positions double-acting series A and B to tank	<b>W016</b>
	3 positions double-acting series A to tank B blocked	<b>W017</b>
	3 positions double-acting series B to tank A blocked	<b>W018</b>

**NOTE:** W012, and W013 spools need a special machining on the valve body.

# HC-D16 Series

Sectional Directional Control Valve



## SPOOL TYPE

### Spool type

STANDARD

**A**

METERED

**B**

### Spool identification example:

**W001A**

Spool 3 positions double-acting  
STANDARD

**W001B**

Spool 3 positions double-acting  
METERED

### Spools with restricted service ports

HYDRAULIC SCHEMATIC	CIRCUIT	RESTRICTION ON DIAMETER (MM)	CODE	SECTION (MM <sup>2</sup> )
	A-B IN T	0,10	<b>J10</b>	3,13
		0,15	<b>J15</b>	4,70
		0,20	<b>J20</b>	6,25
	A IN T	0,10	<b>K10</b>	3,13
		0,15	<b>K15</b>	4,70
		0,20	<b>K20</b>	6,25
	B IN T	0,10	<b>Y10</b>	3,13
		0,15	<b>Y15</b>	4,70
		0,20	<b>Y20</b>	6,25

### Order example

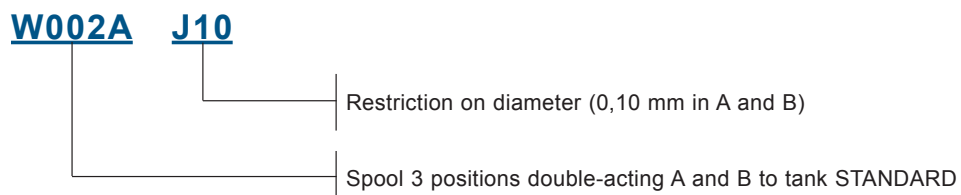

# HC-D16 Series

Sectional Directional Control Valve



## SPOOL ACTUATION

### Spool actuation identification

#### DIMENSIONS

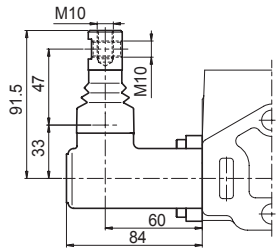

#### DESCRIPTION

Protected lever

#### CLAMPING TORQUE

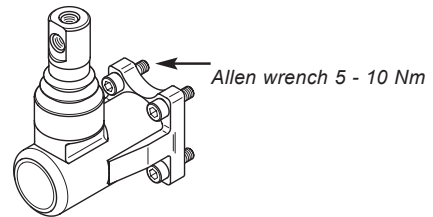

#### ORDERING CODE

**H001**

Protected lever rotated 180°

**H002**

#### DIMENSIONS

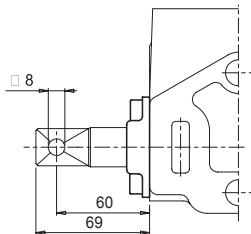

#### DESCRIPTION

Control without lever

#### CLAMPING TORQUE

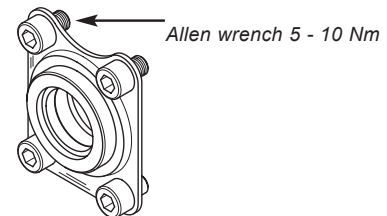

#### ORDERING CODE

**H004**

#### DIMENSIONS

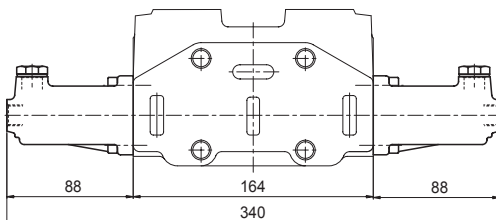

#### DESCRIPTION

Hydraulic actuation

#### CLAMPING TORQUE

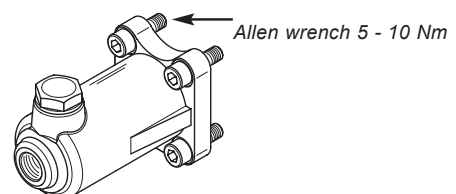

#### ORDERING CODE

**H006**

**NOTE:** leave out the spool return action code

## SPOOL RETURN ACTION

### Springs load values

Spool return kits have three different spring types; following the codes depending on spring loads:

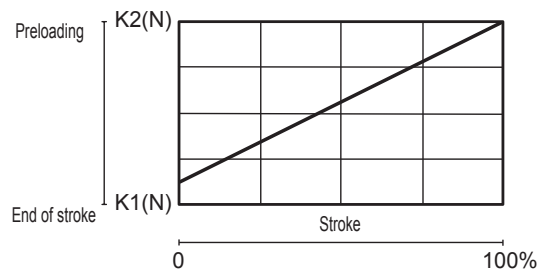

#### STANDARD SPRING

**A**

Preloading

**137,3 N**

End of stroke

**176,6 N**

#### SOFT SPRING

**B**

Preloading

**98,1 N**

End of stroke

**137,3 N**

#### HEAVY SPRING

**C**

Preloading

**196,2 N**

End of stroke

**255 N**

### Spool return kit identification example

**F001A**

3 positions spring-centred spool  
(**standard spring**)

**F001B**

3 positions spring-centred spool  
(**soft spring**)

**F001C**

3 positions spring-centred spool  
(**heavy spring**)

# HC-D16 Series

Sectional Directional Control Valve



## SPOOL RETURN ACTION

### Spools return identification

#### DIMENSIONS

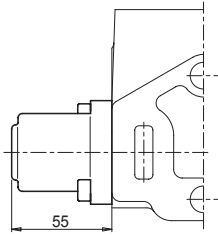

#### DESCRIPTION

3 positions spring-centred spool



#### CLAMPING TORQUE

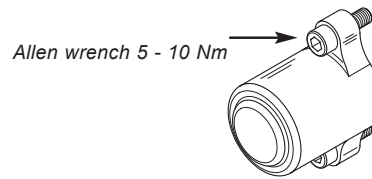

#### ORDERING CODES

**F001A**

**F001B**

**F001C**

#### DIMENSIONS

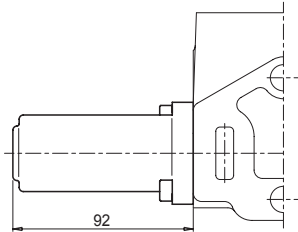

#### DESCRIPTION

3 positions spring-centred spool  
detent in A and B



#### CLAMPING TORQUE

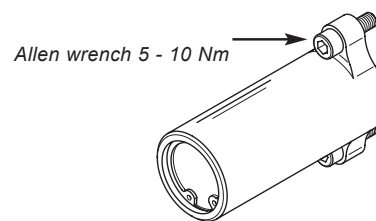

#### ORDERING CODES

**F002A**

3 positions spring-centred spool  
detent in A



**F003A**

3 positions spring-centred spool  
detent in B



**F004A**

4 positions spring-centred spool  
detent in 4<sup>th</sup> position



**F005A**

(only for W012 )

# HC-D16 Series

Sectional Directional Control Valve



## SPOOL RETURN ACTION

### DIMENSIONS

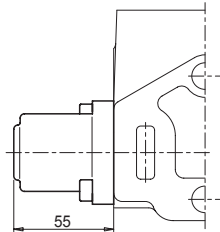

### DESCRIPTION

2 positions in A spring-centred spool



2 positions in B spring-centred spool



### CLAMPING TORQUE

Allen wrench 5 - 10 Nm

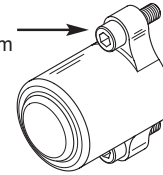

### ORDERING CODES

**F009A**

**F009B**

**F009C**

**F010A**

**F010B**

**F010C**

### DIMENSIONS

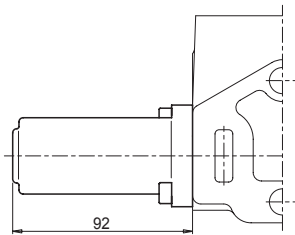

### DESCRIPTION

2 positions detent in A spring-centred spool



2 positions detent in B spring-centred spool



### CLAMPING TORQUE

Allen wrench 5 - 10 Nm

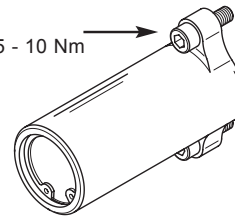

### ORDERING CODES

**F011A**

**F011B**

**F011C**

**F012A**

**F012B**

**F012C**

### DIMENSIONS

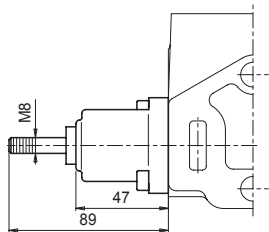

### DESCRIPTION

3 positions spring-centred spool prearrangement dual command



### CLAMPING TORQUE

Allen wrench 5 - 10 Nm

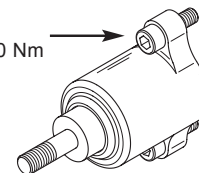

### ORDERING CODES

**F013A**

**F013B**

**F013C**

# HC-D16 Series

Sectional Directional Control Valve



## SPOOL RETURN ACTION

### Pneumatic control classification

#### DIMENSIONS

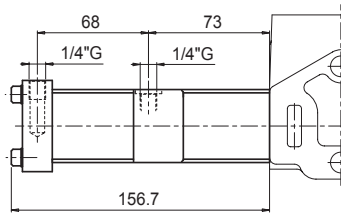

#### CLAMPING TORQUE

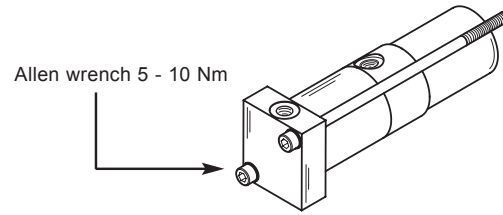

#### DESCRIPTION

#### ORDERING CODES

Pneumatic control ON - OFF



**F020A**

Pneumatic control ON - OFF  
rotated 180°



**F021A**

Proportional pneumatic control



**F022A**

Proportional pneumatic control  
rotated 180°



**F023A**

#### PROPORTIONAL PNEUMATIC CONTROL SPECIFICATIONS

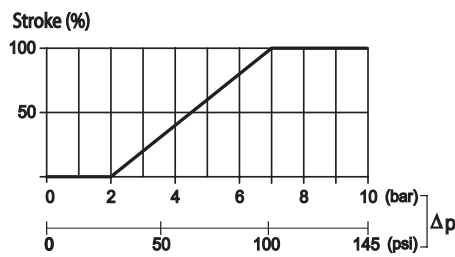

The graphic shows the spool stroke as a function of the pneumatic pressure operating.

# HC-D16 Series

Sectional Directional Control Valve



## SPOOL RETURN ACTION

### DIMENSIONS

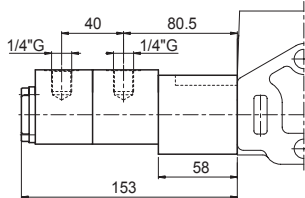

### SPECIFICATIONS

X in A1: it inhibits flow on port A  
X in B1: it inhibits flow on port B

P max. = 350 bar

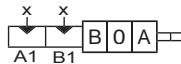

### CLAMPING TORQUE

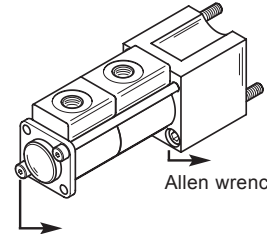

Allen wrench 5 - 10 Nm

Allen wrench 4 - 6 Nm

### DESCRIPTION

Load limit in A and B

**F024A**

**F024C**

Load limit in A and B rotated 180°

**F025A**

**F025C**

### DIMENSIONS

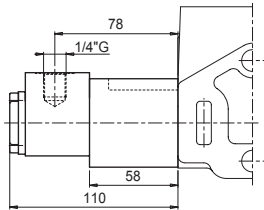

### SPECIFICATIONS

X in A1: it inhibits flow on port A

P max. = 350 bar

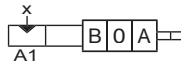

### CLAMPING TORQUE

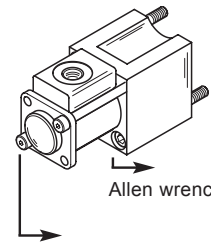

Allen wrench 5 - 10 Nm

Allen wrench 4 - 6 Nm

### DESCRIPTION

Load limit in A

**F026A**

**F026C**

Load limit in A rotated 180°

**F027A**

**F027C**

### DIMENSIONS

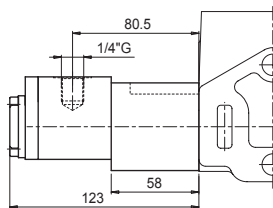

### SPECIFICATIONS

X in B1: it inhibits flow on port B

P max. = 350 bar

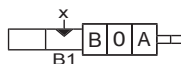

### CLAMPING TORQUE

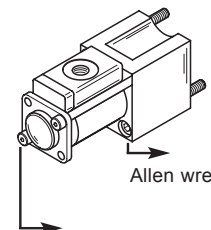

Allen wrench 5 - 10 Nm

Allen wrench 4 - 6 Nm

### DESCRIPTION

Load limit in B

**F028A**

**F028C**

Load limit in B rotated 180°

**F029A**

**F029C**

# HC-D16 Series

Sectional Directional Control Valve



## SPOOL RETURN ACTION

### DIMENSIONS

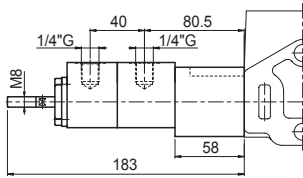

### SPECIFICATIONS

X in A1: it inhibits flow on port A  
X in B1: it inhibits flow on port B

P max. = 350 bar

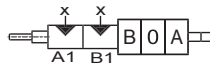

### CLAMPING TORQUE

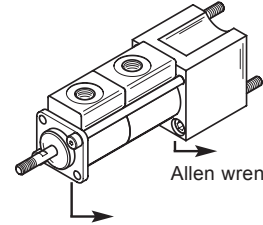

Allen wrench 5 - 10 Nm

Allen wrench 4 - 6 Nm

### DESCRIPTION

Load limit in A and B dual control

**F030A**

**F030C**

Load limit in A and B rotated 180° dual control

**F031A**

**F031C**

### DIMENSIONS

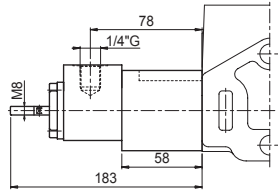

### SPECIFICATIONS

X in A1: it inhibits flow on port A

P max. = 350 bar



### CLAMPING TORQUE

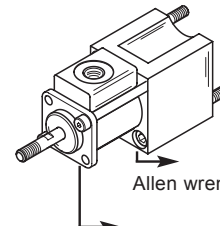

Allen wrench 5 - 10 Nm

Allen wrench 4 - 6 Nm

### DESCRIPTION

Load limit in A dual control

**F032A**

**F032C**

Load limit in A rotated 180° dual control

**F033A**

**F033C**

### DIMENSIONS

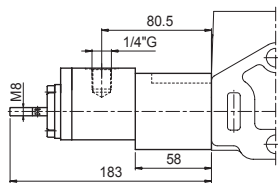

### SPECIFICATIONS

X in B1: it inhibits flow on port B

P max. = 350 bar

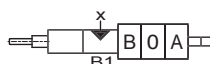

### CLAMPING TORQUE

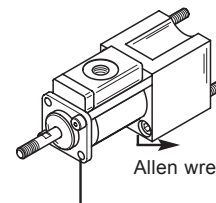

Allen wrench 5 - 10 Nm

Allen wrench 4 - 6 Nm

### DESCRIPTION

Load limit in B dual control

**F034A**

**F034C**

Load limit in B rotated 180° dual control

**F035A**

**F035C**

# HC-D16 Series

Sectional Directional Control Valve



## SPOOL RETURN ACTION

### Electrical load limit kit specifications

POWER SUPPLY	CONTACTS CAPACITY	PROTECTION DEGREE	TEMPERATURE RANGE
12 VDC	3 A	IP 65	da -25°C a +90°C
24 VDC	1,5 A		

### Operational diagram

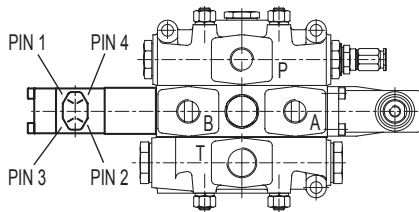

CONTROL in A & B = connect PIN 1-4 and 2-3  
 CONTROL in A = connect PIN 2-3  
 CONTROL in B = connect PIN 1-4

### Wiring diagram

(NORMALLY CLOSED CONTACTS)

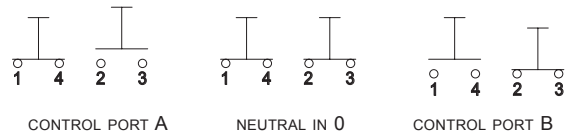

In case of inductive loads it is advisable to connect the terminals of the work port (solenoid) to a 200 VDC - 3A diode.

### Electrical load limit kit identification

#### DIMENSIONS

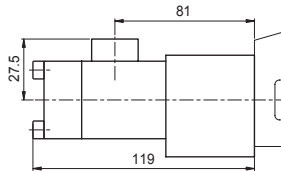

#### CLAMPING TORQUE

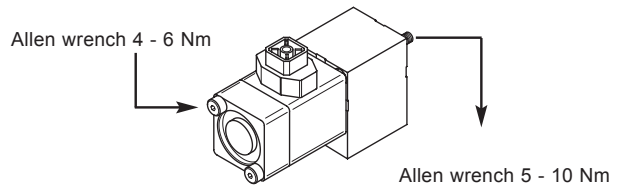

#### DESCRIPTION

Electrical load limit  
(normally closed contacts)

**F0360**

Electrical load limit rotated 180°  
(normally closed contacts)

**F0370**

Electrical load limit  
(normally open contacts)

**F0450**

Electrical load limit rotated 180°  
(normally open contacts)

**F0460**

**NOTE:** a HIRSCHMANN female connector, type G4 W1F, is available on request.  
(code 413000045, to be ordered separately).

# HC-D16 Series

Sectional Directional Control Valve



## SPOOL RETURN ACTION

### Electrohydraulic control specifications

<b>MAX INLET PRESSURE</b>	<b>REDUCED PRESSURE</b>	<b>BACK PRESSURE ON T</b>
350 bar	16 bar	3 bar
<b>FILTERING DEGREE</b>	<b>RECOMMENDED PILOT PIPE SIZE</b>	<b>TEMPERATURE RANGE</b>
25 $\mu$ assoluti	$\varnothing$ 6 mm - 1/4" BSP	-20° +80°

### Electrohydraulic ON-OFF control with fixed pressure reducing valve

It is suitable to have an 8 bar backpressure on the free flow channel to make the system working.

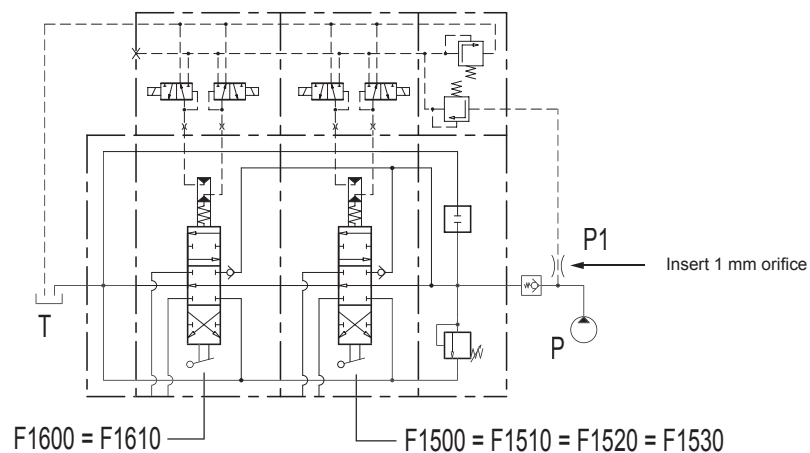

### Electrohydraulic Proportional control with fixed pressure reducing valve

It is suitable to have an 8 bar backpressure on the free flow channel to make the system working.

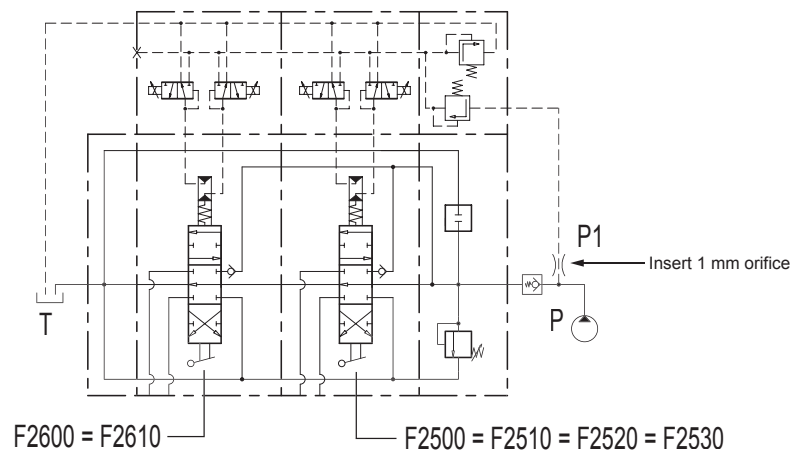

# HC-D16 Series

Sectional Directional Control Valve



## SPOOL RETURN ACTION

### Electrohydraulic control ON-OFF identification

#### DIMENSIONS

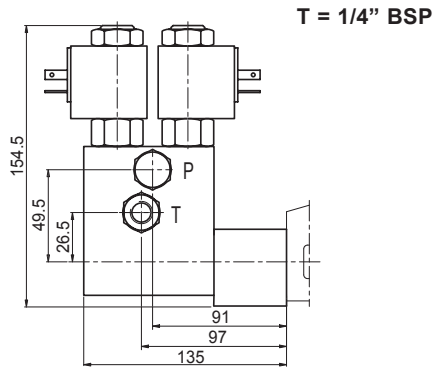

#### CLAMPING TORQUE

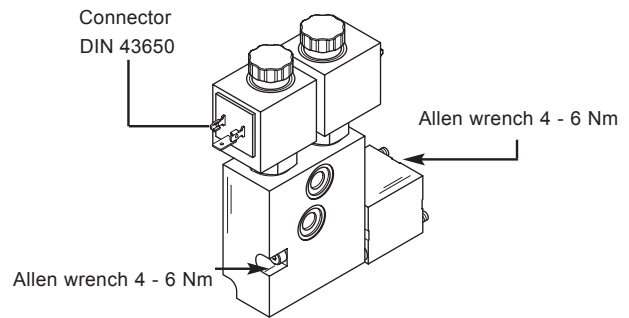

#### DESCRIPTION

**3 positions**  
electrohydraulic control ON - OFF

#### ORDERING CODES

(12 VDC)  
**F0600**  
19 W - 1,58 A

(24 VDC)  
**F0610**  
19 W - 0,81 A

#### DIMENSIONS

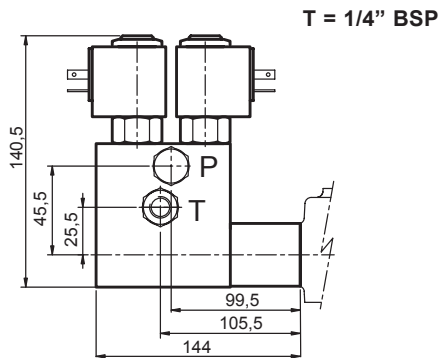

#### CLAMPING TORQUE

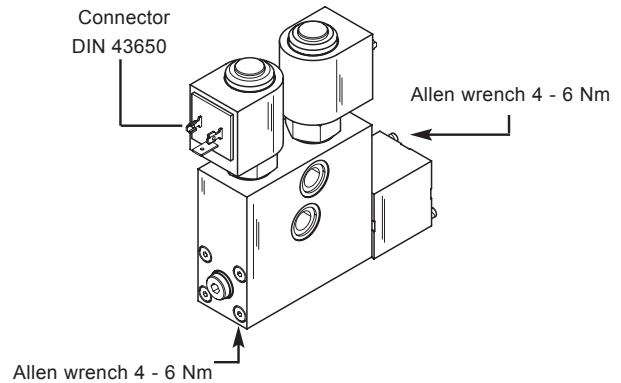

#### DESCRIPTION

**3 positions electrohydraulic control ON - OFF**  
(stackable with Proportional control)

#### ORDERING CODES

(12 VDC)  
**F1600**  
19 W - 1,58 A

(24 VDC)  
**F1610**  
19 W - 0,81 A

Electrohydraulic ON-OFF control stackable with electrohydraulic proportional control (F2600 = F2610)

Control kit already includes orifices to make spool displacement more gradual.

# HC-D16 Series

Sectional Directional Control Valve



## SPOOL RETURN ACTION

### Electrohydraulic control Proportional identification

#### DIMENSIONS

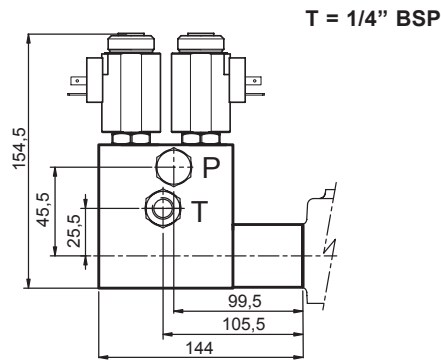

#### CLAMPING TORQUE

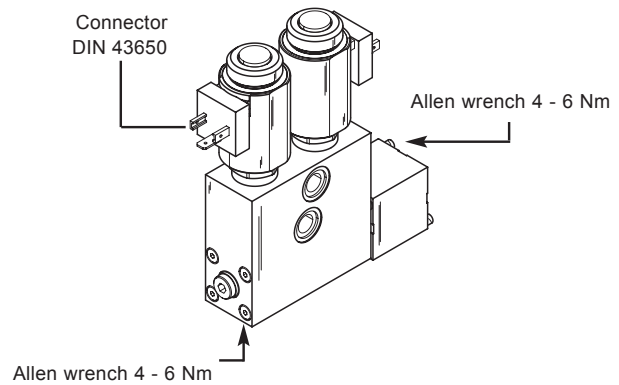

#### DESCRIPTION

**3 positions**  
electrohydraulic control **PROPORTIONAL**

#### ORDERING CODES

(12 VDC)

**F2600**

(24 VDC)

**F2610**

Proportional control kit, mechanically retrooperated, allows the maximum precision of positioning, limiting the hysteresis.

The control is operated with PWM control of the current.  
PWM frequency suggested: 60-80 Hz

#### REGULAR CURRENT

Nominal voltage (V)	Resistance (R <sub>20</sub> ) (Ohm)	Current (min) (A)	Current (max) (A)
12 VDC	3,7	0,9	1,8
24 VDC	15,5	0,45	0,9

# HC-D16 Series

Sectional Directional Control Valve



## SPOOL RETURN ACTION

Electrohydraulic control with fixed pressure reducing valve identification

### DIMENSIONS

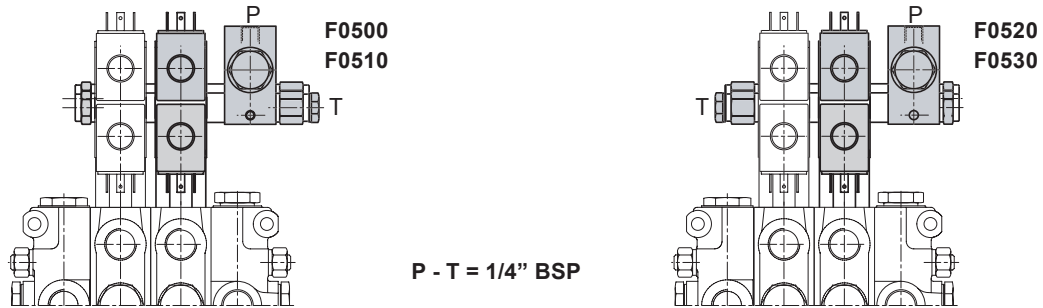

### DESCRIPTION

Electrohydraulic control ON - OFF  
(fixed pressure reducing valve) P-T inlet inside

Electrohydraulic control ON - OFF  
(fixed pressure reducing valve) P inlet T outlet

Electrohydraulic control ON - OFF  
(fixed pressure reducing valve) P-T inlet inside

Electrohydraulic control ON - OFF  
(fixed pressure reducing valve) P inlet T outlet

Electrohydraulic control PROPORTIONAL  
(fixed pressure reducing valve) P-T inlet inside

Electrohydraulic control PROPORTIONAL  
(fixed pressure reducing valve) P inlet T outlet

### ORDERING CODES

(12 VDC)  
**F0500**  
19 W - 1,58 A

(12 VDC)  
**F0520**  
19 W - 1,58 A

(12 VDC)  
**F1500**  
19 W - 1,58 A

(12 VDC)  
**F1520**  
19 W - 1,58 A

(12 VDC)  
**F2500**

(12 VDC)  
**F2520**

(24 VDC)  
**F0510**  
19 W - 0,81 A

(24 VDC)  
**F0530**  
19 W - 0,81 A

(24 VDC)  
**F1510**  
19 W - 0,81 A

(24 VDC)  
**F1530**  
19 W - 0,81 A

(24 VDC)  
**F2510**

(24 VDC)  
**F2530**

### Adaptable only F0600, F0610, F2600, F2610 control kit

**NOTE:** F0500, F0510, F0520, F0530, F1500, F1510, F1520, F1530, F2500, F2510, F2520 and F2530 control kits can be used only with left inlet side monoblocks.

# HC-D16 Series

Sectional Directional Control Valve



## SPOOL RETURN ACTION

### Electropneumatic control identification

#### DIMENSIONS

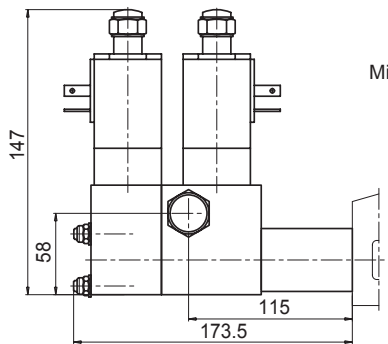

Minimum working pressure: 5 bar

#### CLAMPING TORQUE

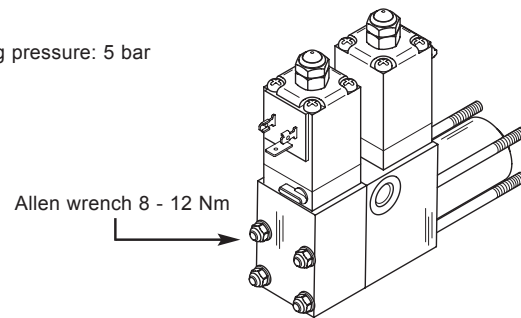

#### DESCRIPTION

**3 positions**  
electropneumatic control ON - OFF

#### ORDERING CODES

(12 VDC)

**F0620**

7 W - 0,58 A

(24 VDC)

**F0630**

7 W - 0,29 A

# HC-D16 Series

Sectional Directional Control Valve



## SPOOL RETURN ACTION

### Control tie rod assembly

The length of the control tie rod, will change depending on the section numbers; in this way will be easy install in the right way the sections and avoid any misassembly.

Each kit is composed by 2 tie rods, 2 plug, 2 connection ports and spacers according to the section number (see pict.A)

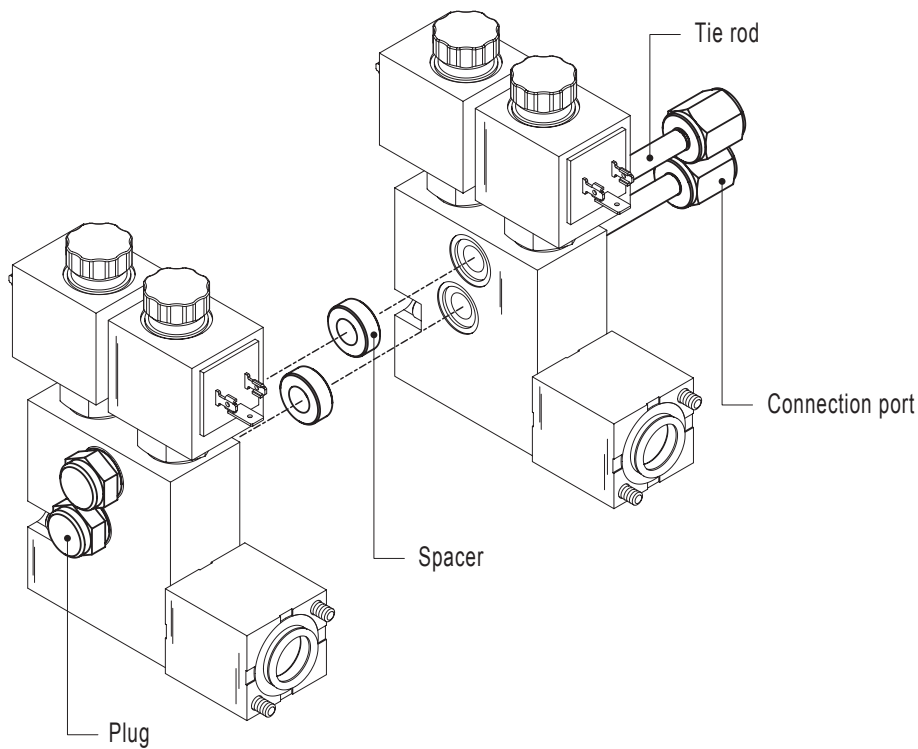

**NOTE:** the control tie rod kit has to be always separately ordered.

Reducing valve, combined with electrohydraulic, electropneumatic and proportional control kit has to be calculated as a normal working section

#### **ORDER EXAMPLE:**

Complete valves with 3 sections F1600 **requires a complete tie-rod kit /3**

Complete valves with 2 sections F1600 and 1 section with F1500 (reducing valve) **requires a complete tie-rod kit /4**

# HC-D16 Series

Sectional Directional Control Valve



## WORK SECTION TYPE

### Section work identification

DESCRIPTION

ORDERING CODES

Parallel circuit section

RP

Series circuit section

RS

### Thread type

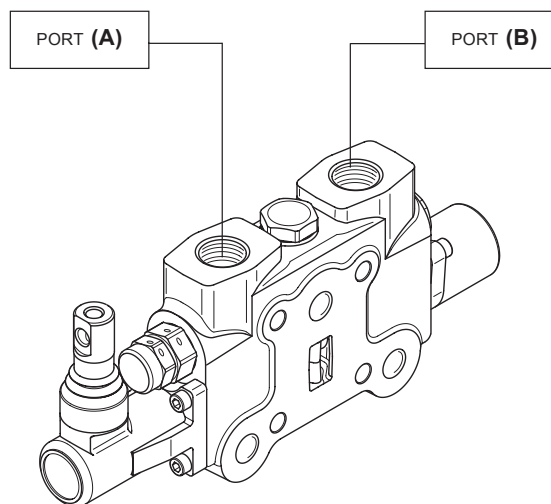

SERVICE PORTS (A - B)

G05

U05

# HC-D16 Series

Sectional Directional Control Valve



## AUXILIARY VALVES

### Auxiliary valves identification

#### ANTISHOCK VALVE (ARV)

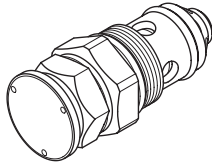

HYDRAULIC SCHEMATIC



ORDERING CODES

**01 PA**

Port (A)

**01 PB**

Port (B)

SETTING RANGES (BAR)

Range (A)

0 / 150 - at full flow

0 / 120 - at min. flow

Range (C)

231 / 280 - at full flow

201 / 250 - at min. flow

Range (B)

151 / 230 - at full flow

121 / 200 - at min. flow

Range (D)

281 / 350 - at full flow

251 / 350 - at min. flow

#### ANTICAVITATION VALVE

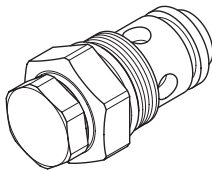

HYDRAULIC SCHEMATIC



ORDERING CODES

**02 PA**

Port (A)

**02 PB**

Port (B)

#### COMBINATED VALVE

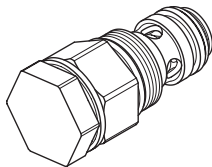

HYDRAULIC SCHEMATIC



ORDERING CODES

**03 PA**

Port (A)

**03 PB**

Port (B)

SETTING RANGES (BAR)

Range (A)

30 / 95 - at full flow

30 / 65 - at min. flow

Range (C)

151 / 260 - at full flow

121 / 230 - at min. flow

Range (B)

96 / 150 - at full flow

66 / 120 - at min. flow

Range (D)

261 / 350 - at full flow

231 / 350 - at min. flow

#### VALVE PLUGGED

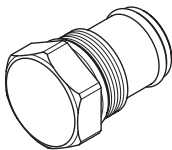

HYDRAULIC SCHEMATIC



ORDERING CODES

**05 PA**

Port (A)

**05 PB**

Port (B)

**NOTE:** sections designed to house auxiliary valve option require double choice on work ports A and B.  
Always indicate setting value when using antishock auxiliary valves and combinated valves:

SETTING AT FULL FLOW = 01 PA 120  
SETTING AT MIN. FLOW = 01 PA 120-A

# HC-D16 Series

Sectional Directional Control Valve



## INTERMEDIATE SECTIONS

Order example:  
INTERMEDIATE INLET SECTION

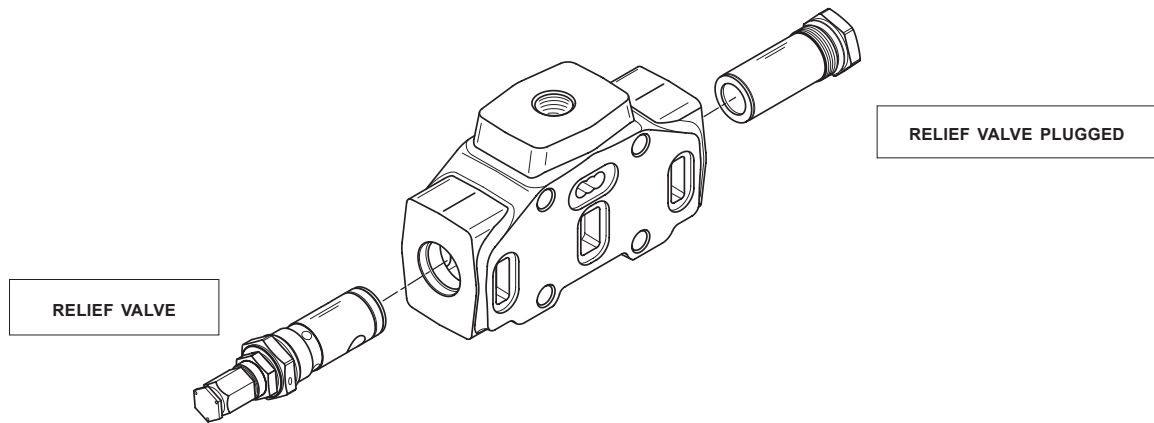

- BE** intermediate inlet section type
- 009** valve arrangement
- (150)** setting direct acting pressure valve
- A G05** inlet and thread position

### Inlet side

HYDRAULIC DIAGRAM	LAYOUT	DESCRIPTION + CODE
		<p>INTERMEDIATE INLET SECTION</p> <p><b>BE</b></p>
		<p>INTERMEDIATE SECTION WITH PRESSURE RELIEF VALVE</p> <p><b>BV*</b></p>

(\*) Omit the code for inlet positioning and type of thread

# HC-D16 Series

Sectional Directional Control Valve



## INTERMEDIATE SECTIONS

### Operation of intermediate inlet section

#### TYPE E

The intermediate inlet section is driven by two pumps (P+P1).

The downstream elements can be set to a lower pressure than those the upstream one by adjusting the pressure relief valve of the intermediate section in question.

#### TYPE V

The intermediate inlet section and the elements are driven by a single pump (P).

The downstream elements can be set to a lower pressure than those the upstream one by adjusting the pressure relief valve of the intermediate section in question.

### Valves identification

TYPE	DESIGN	DIAGRAM	DESCRIPTION
<b>2</b>			Pilot operated pressure relief valve
<b>3</b>			Relief valve plugged

TYPE	DESIGN	DIAGRAM	DESCRIPTION
<b>4</b>			Main anticavitation check valve
<b>11</b>			Plug with pressure gauge connection

### Valve arrangement

Example: **009 = 2A-3B**

Pressure relief valve in port A side

Plug replaces pressure relief valve in port B side

The code identifies: with a number, the type of valve;

with a letter, its position on the inlet section.

(A) = spool action side

(B) = spool return action side

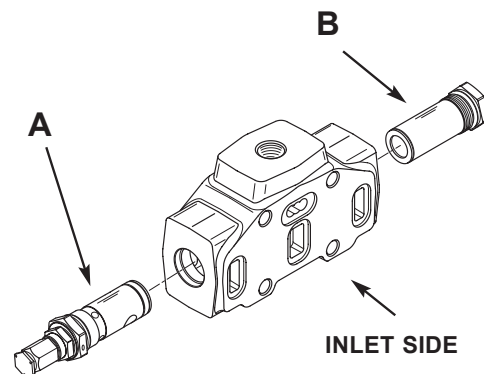

# HC-D16 Series

Sectional Directional Control Valve



## INTERMEDIATE SECTIONS

### Valves combination

<b>009</b>	<b>010</b>	<b>016</b>	<b>018</b>	<b>019</b>	<b>020</b>	<b>027</b>	<b>029</b>	<b>030</b>	<b>037</b>	<b>085</b>	<b>086</b>	<b>087</b>	
2A-3B	2A-4B	2A-11B	3A-2B	3A-3B	3A-4B	3A-11B	4A-2B	4A-3B	4A-11B	11A-2B	11A-3B	11A-4B	

### Inlet and thread available

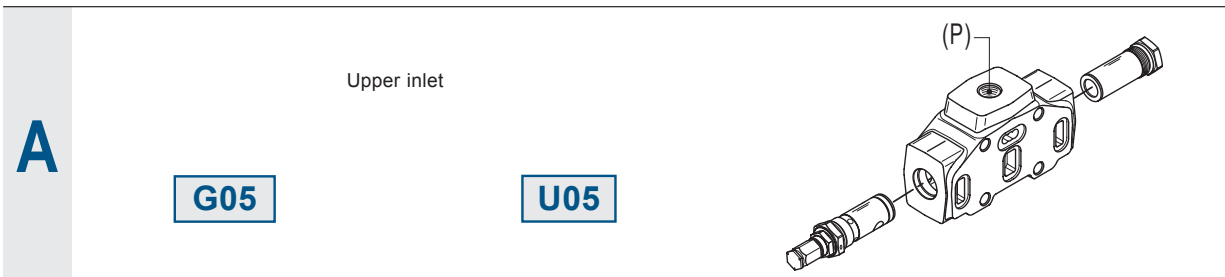

### Complete configuration samples for HC-D16 with intermediate inlet section (BE)

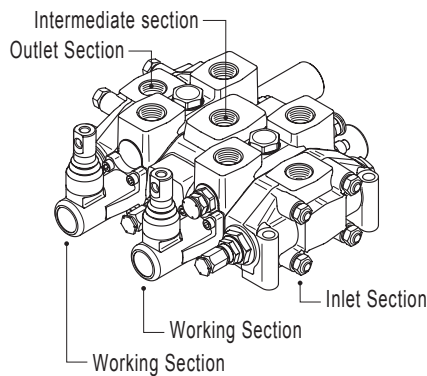

### HC-D16/2

- IR 001 150 A G05 ..... Right inlet section
- W001A H001 F001A RP G05 ..... Working section
- BE 009 120 A G05** ..... Intermediate inlet section
- W001A H001 F001A RP G05 ..... Working section
- TJ A G05 ..... Outlet section

# HC-D16 Series

Sectional Directional Control Valve



## INTERMEDIATE SECTIONS

Order example:  
INTERMEDIATE OUTLET SECTION

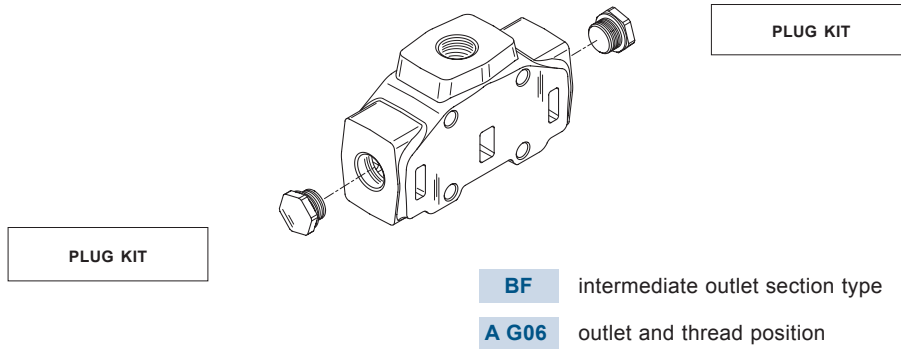

### Inlet side

HYDRAULIC DIAGRAM	LAYOUT	DESCRIPTION + CODE
		<p>INTERMEDIATE OUTLET SECTION WITH SINGLE TANK RETURN</p> <p><b>BF</b></p>
		<p>INTERMEDIATE OUTLET SECTION WITH TWO TANK RETURNS</p> <p><b>BG</b></p>

### Operation of intermediate outlet section

#### TYPE F

The above outlet section allows the flow of oil of the two pumps and the tank ports to be piped to a single outlet T.

#### TYPE G

The section in question allows the flow of oil of the two pumps to be piped in two outlets:  
 - HPCO for powering another directionale control valve  
 - T for discharge of the work ports  
 In order to obtain this, the two T need to be linked.

# HC-D16 Series

Sectional Directional Control Valve



## INTERMEDIATE SECTIONS

Outlet and thread available

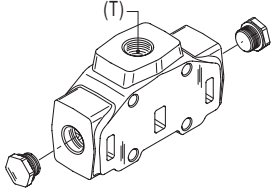
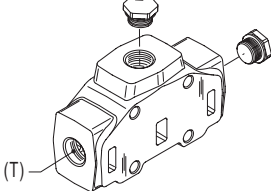
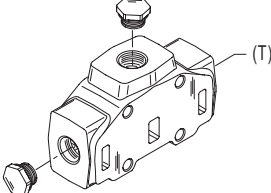
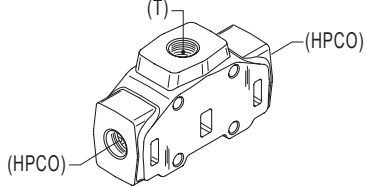
<b>BF</b>	
<b>A</b>	Upper inlet <div style="display: flex; justify-content: space-around; align-items: center;"> <div style="border: 1px solid black; padding: 2px 5px;"><b>G06</b></div> <div style="border: 1px solid black; padding: 2px 5px;"><b>U06</b></div> </div> 
<b>G</b>	Front outlet side A <div style="display: flex; justify-content: space-around; align-items: center;"> <div style="border: 1px solid black; padding: 2px 5px;"><b>G06</b></div> <div style="border: 1px solid black; padding: 2px 5px;"><b>U06</b></div> </div> 
<b>H</b>	Rear outlet side B <div style="display: flex; justify-content: space-around; align-items: center;"> <div style="border: 1px solid black; padding: 2px 5px;"><b>G06</b></div> <div style="border: 1px solid black; padding: 2px 5px;"><b>U06</b></div> </div> 
<b>BG</b>	
<b>J</b>	Upper outlet HPCO - front side A and rear side B to T <div style="display: flex; justify-content: space-around; align-items: center;"> <div style="border: 1px solid black; padding: 2px 5px;"><b>G06</b></div> <div style="border: 1px solid black; padding: 2px 5px;"><b>U06</b></div> </div> 

Complete configuration samples for HC-D16 with intermediate outlet section (BF)

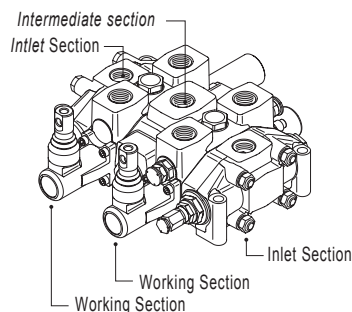

### HC-D16/2

- IR 009 150 A G05 ..... Right inlet section
- W001A H001 F001A RP G05 ..... Working section
- BF A G06 ..... Intermediate inlet section
- W001A H001 F001A RP G05 ..... Working section
- IL 009 150 A G05 ..... Left inlet section

# HC-D16 Series

Sectional Directional Control Valve



## OUTLET SECTION

Order example:  
1 outlet

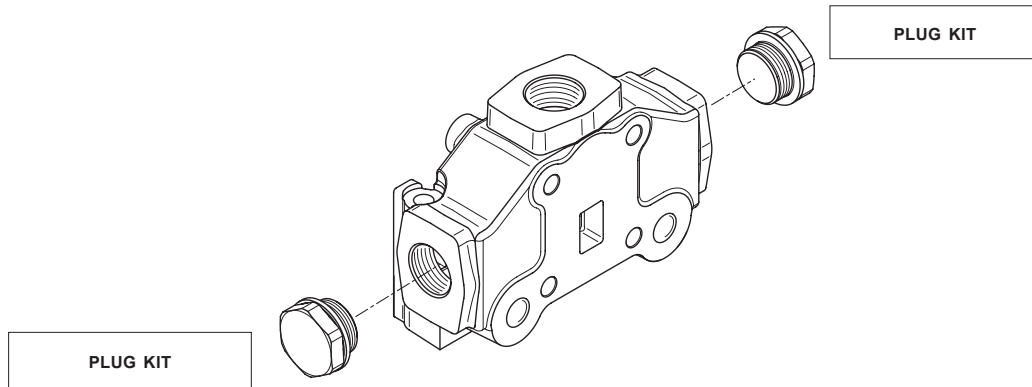

**TJ** outlet side type

**A G06** outlet and thread available

Order example:  
HPCO version outlet

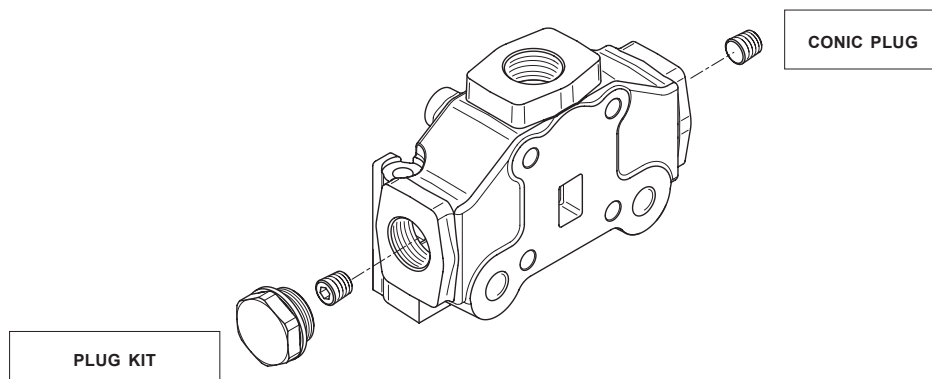

**TM** outlet side type

**M G06** outlet and thread available

# HC-D16 Series

Sectional Directional Control Valve



## OUTLET SECTION

### Outlet with single tank classification

HYDRAULIC DIAGRAM	LAYOUT	DESCRIPTION + CODE
		<p>OUTLET SECTION WITH <b>SINGLE RETURN (T) RIGHT-SIDE INLET (P)</b></p> <p><b>TJ</b></p>
		<p>OUTLET SECTION WITH <b>SINGLE RETURN (T) LEFT-SIDE INLET (P)</b></p> <p><b>TK</b></p>

### Outlet and thread available

<b>A</b>	Upper outlet	<b>G06</b>	<b>U06</b>	
<b>C</b>	Central outlet	<b>G06</b>	<b>U06</b>	
<b>G</b>	Front outlet side A	<b>G06</b>	<b>U06</b>	<p style="text-align: right;"><b>ONLY FOR TK</b></p>
<b>H</b>	Rear outlet side B	<b>G06</b>	<b>U06</b>	<p style="text-align: right;"><b>ONLY FOR TJ</b></p>

# HC-D16 Series

Sectional Directional Control Valve



## OUTLET SECTION

### Outlet with two tanks classification

HYDRAULIC DIAGRAM	LAYOUT	DESCRIPTION + CODE
		<p>OUTLET SECTION WITH <b>TWO RETURNS</b> RIGHT-SIDED INLET (P)</p> <p><b>TM</b></p>
		<p>OUTLET SECTION WITH <b>TWO RETURNS</b> LEFT-SIDED INLET (P)</p> <p><b>TN</b></p>

### Outlet and thread available

<b>M</b>	HPCO upper outlet T (TANK) side outlet B	<b>G06</b>	<b>U06</b>		ONLY FOR TM
<b>N</b>	HPCO upper outlet T (TANK) front outlet side A	<b>G06</b>	<b>U06</b>		ONLY FOR TN
<b>P</b>	HPCO central outlet T (TANK) side outlet B	<b>G06</b>	<b>U06</b>		ONLY FOR TM
<b>Q</b>	HPCO central outlet T (TANK) front outlet side A	<b>G06</b>	<b>U06</b>		ONLY FOR TN

# HC-D16 Series

Sectional Directional Control Valve



## OUTLET SECTION

### Outlet with two tanks classification

HYDRAULIC DIAGRAM	LAYOUT	DESCRIPTION + CODE
		<p>OUTLET SECTION WITH <b>TWO RETURNS</b> RIGHT-SIDED INLET (P)</p> <p><b>TM</b></p>
		<p>OUTLET SECTION WITH <b>TWO RETURNS</b> LEFT-SIDED INLET (P)</p> <p><b>TN</b></p>

### Outlet and thread available

<b>M</b>	HPCO upper outlet T (TANK) side outlet B	<b>G06</b>	<b>U06</b>		ONLY FOR <b>TM</b>
<b>N</b>	HPCO upper outlet T (TANK) front outlet side A	<b>G06</b>	<b>U06</b>		ONLY FOR <b>TN</b>
<b>P</b>	HPCO central outlet T (TANK) side outlet B	<b>G06</b>	<b>U06</b>		ONLY FOR <b>TM</b>
<b>Q</b>	HPCO central outlet T (TANK) front outlet side A	<b>G06</b>	<b>U06</b>		ONLY FOR <b>TN</b>

# HC-D16 Series

Sectional Directional Control Valve



## INSTALLATION AND MAINTENANCE

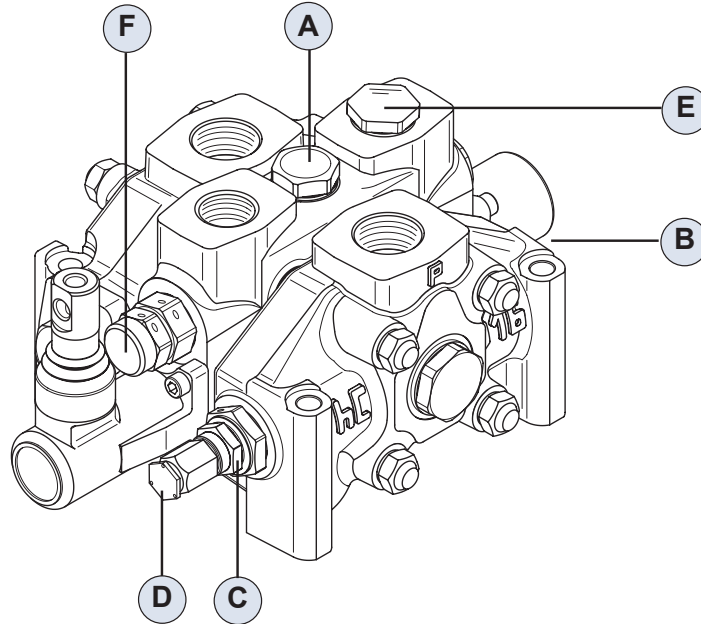

### General clamping torque

POSITION	DESCRIPTION	CLAMPING TORQUE (Nm)
A	load check valve plug	80
B	plug to replace pressure relief valve	120
C	pressure relief valve body	120
D	pressure relief valve cap	20
E	fittings in service ports A-B-P-T	G05 = 150 / G06 = 240 U05 = 150 / U06 = 240
F	clamping torque auxiliary valve	see table (X)

TABLE (X)

ANTISHOCK VALVE PLUG  
**20 Nm**

ANTICAVITATION VALVE PLUG  
**20 Nm**

COMBINATED VALVE PLUG  
**20 Nm**

ANTISHOCK VALVE CAP  
**120 Nm**

ANTICAVITATION VALVE CAP  
**120 Nm**

COMBINATED VALVE CAP  
**120 Nm**

PLUG REPLACES VALVE  
**120 Nm**

# HC-D16 Series

Sectional Directional Control Valve



## INSTALLATION AND MAINTENANCE

### Assembly instructions

Since our directional control valve casings have symmetrical galleries, they can be converted from right-side inlet (IR) to left-side inlet (IL) simply by turning the spool and relative controls through 180°.

This operation is not possible when using spool types: 012- 013.

Recommended curve for our standard directional control valves **A01** ( see remote controls catalogue).

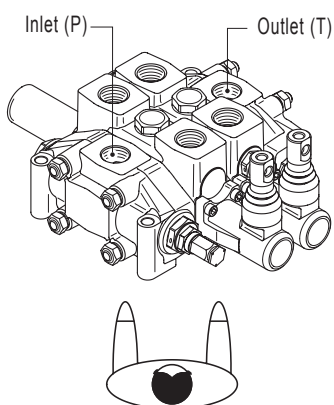

Directional control valve with left inlet (IL)

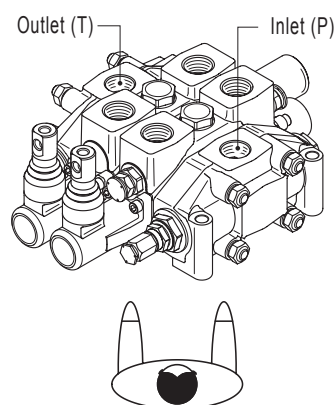

Directional control valve with right inlet (IR)

### Product identification

An identification plate is put on every HC-D16 sectional valve.

